

„Mass production in millions is no problem for us“



RINGSPANN is one of the world's leading manufacturers in the field of freewheel technology. In order to give designers of e-bike drives maximum scope for the realization of innovative bottom bracket and transmission solutions, the company now offers four different types of cage freewheels. They are characterized by performance-oriented additional functions and enable e-drive developers to implement space-optimized and compact drive concepts. Read here why the forward-looking freewheel design from RINGSPANN even reduces the work in module assembly.

If we take just the quantities produced as a yardstick, RINGSPANN is one of the world's top suppliers of cage freewheels for the booming e-bike industry. Based on its comprehensive freewheel know-how, the company not only entered development work at an early stage, but also installed highly automated production processes for the large-scale production of e-bike freewheels in good time at its main plant in Bad Homburg. "Today, we supply renowned manufacturers in the industry with various types of freewheels, whereby annual batch sizes of two million pieces and more are no problem for us", reports Thomas Heubach, who heads the freewheel division at RINGSPANN and is significantly involved in many product innovations. Under his direction, the current selection of cage freewheels for use in e-bike drives has now grown to four basic types. From a technological point of view, they are likely to be among the best that the market currently has to offer in this field of e-mobility. Depending on the version, they not only allow the transmission of the highest torques or their targeted limitation; they also enable the realization of space-saving and reduced part drive systems, which ultimately even reduce the manufacturer's assembly work.

Highest quality standards

RINGSPANN offers all four types of e-bike freewheels for shafts with diameters of approx. 25 - 60 mm. Their sprags are all made of hardened chrome steel and their cages are made of polyamide. Depending on the design, they are predestined for use on the shaft of the bottom bracket or in the gearbox of the drive unit. "And what applies to all our freewheels also applies here: all functional elements of their design meet the highest quality standards and are optimally matched to each other", emphasizes Thomas Heubach.

Type E cage freewheels have now proven themselves millions of times in practical e-bike use. They impress with their high transferable torque of up to 520 Nm, which makes them an extremely durable and robust universal solution for many different e-bike drive systems. According to Thomas Heubach, the torque capacity of these sprag freewheels is "three times higher than that of drawn cup roller clutch freewheels". In addition, their optimized geometry allows high component tolerances in the design environment – for example, when installing between customer-supplied inner and outer rings.

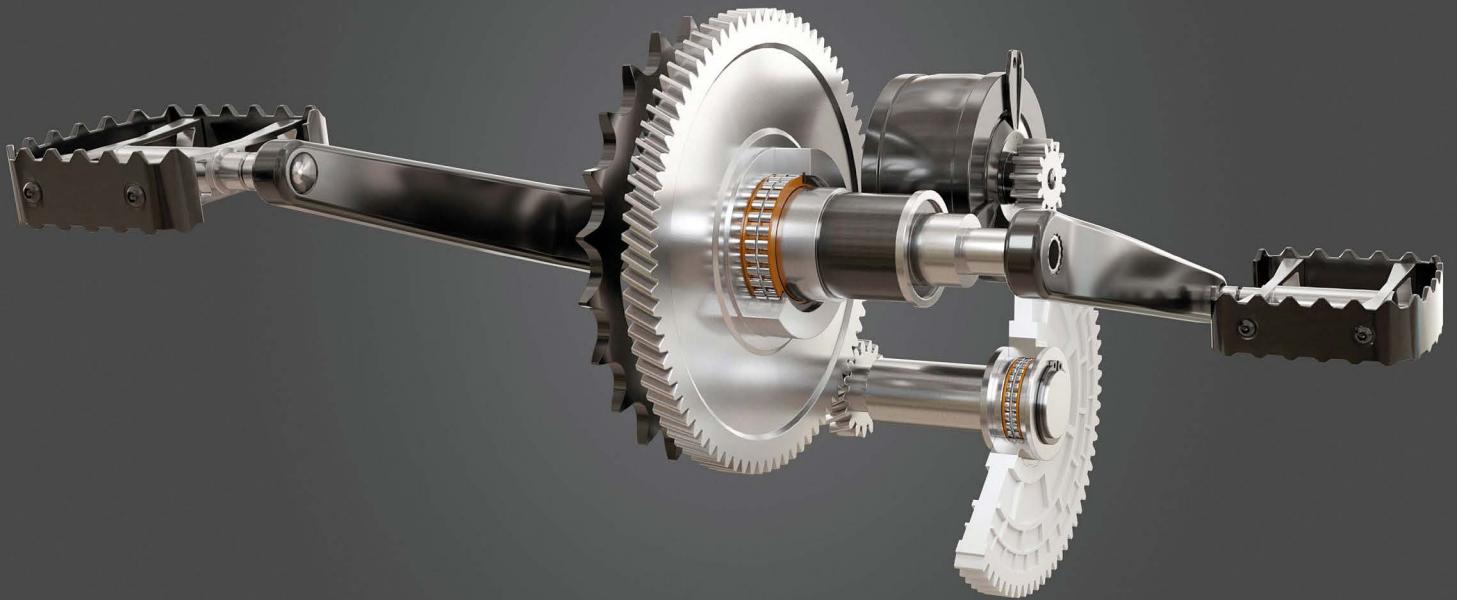

Depending on the version, e-bike freewheels from RINGSPANN are suitable for shafts with diameters of approx. 25 - 60 mm and are predestined for use on the shaft of the bottom bracket or in the gearbox of the drive unit.

Capping torque peaks

The RINGSPANN type F freewheel has a different application focus. This cage freewheel is predestined for use on the bottom bracket shaft, where it protects against overload thanks to its integrated torque limitation. Thomas Heubach explains, "Extremely high torques can occur on the bottom bracket shaft of an e-bike, depending on the application and rider. For this scenario, we have developed the Type F, whose sprags are characterized by a special design. With appropria-

te component tuning, it enables targeted slipping as soon as the application-specific limit torque is exceeded. This not only protects the freewheel itself, but also all adjacent components of the drive." In this respect, the e-bike F freewheel from RINGSPANN is also an ideal solution for applications in which the maximum torque of the bottom bracket cannot be predicted and therefore cannot be designed exactly.

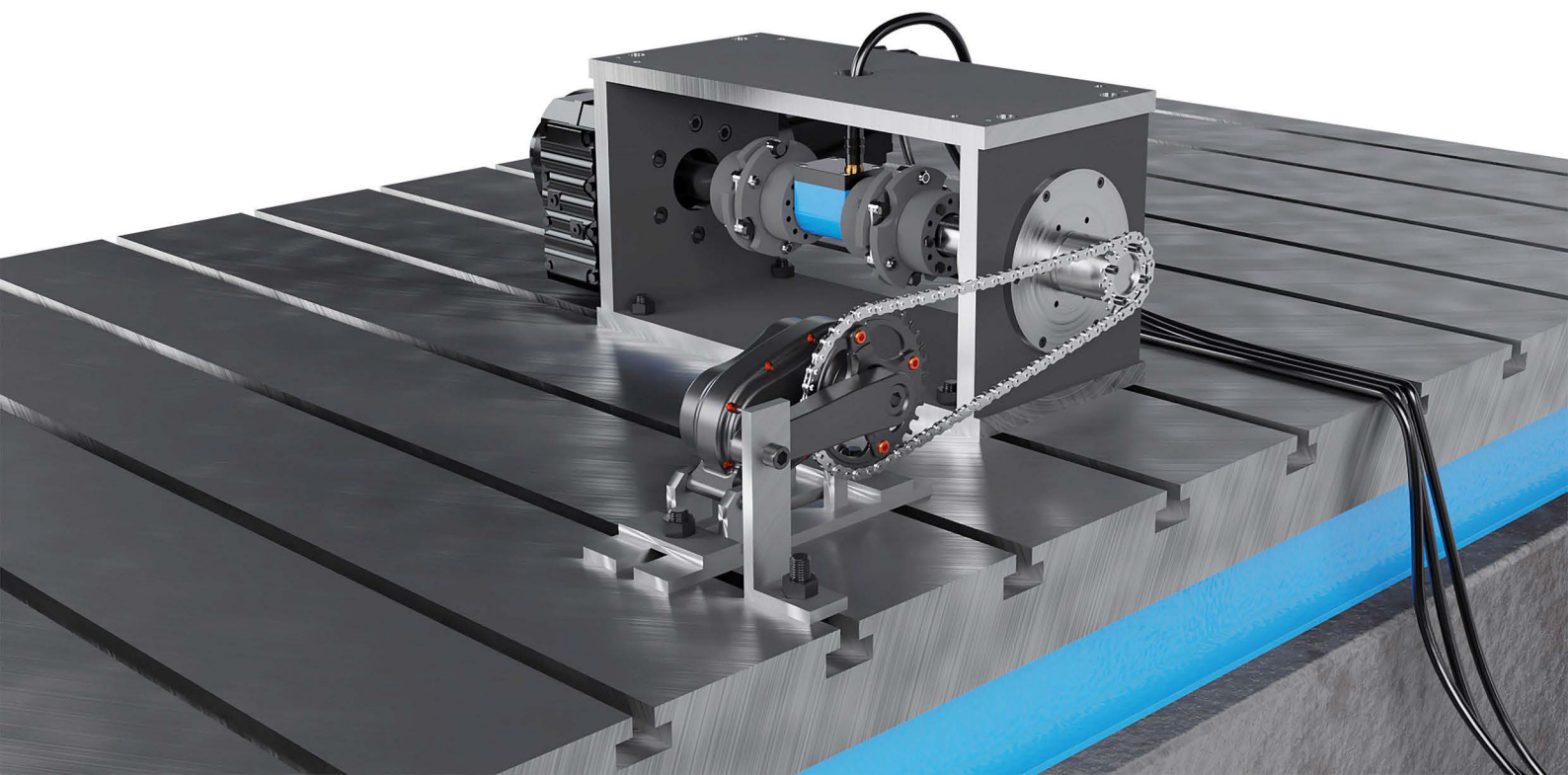



Innovations replace bearing

The latest RINGSPANN innovations in the field of e-drive freewheels include the two types ER and HRL. These cage freewheels are regarded as a pioneering premium solution for coupling and uncoupling the electric motor, as they leave the designers plenty of leeway for the realization of space-optimized and part reduced drive systems. The reason for this: both designs reduce the design work for the usual bearing of the freewheels. While the type ER already has an integrated radial bearing, the type HRL gains points with an integrated radial and axial bearing. "When using these cage freewheels, the e-drive designer can therefore dispense with space-consuming roller bearing assemblies. As a result, they can design the drive more compactly and also reduce the costs of assembling the entire assembly by reducing parts. Or they can use the space gained to install additional functional elements", explains Thomas Heubach.

The radial bearing of the ER freewheel is carried out via several travelling pairs of rollers that are integrated into the modified plastic cage. With the HLR type, a special bearing disc on the freewheel also ensures the axial bearing and securing, whereby an additional bearing is not required, even with helical gears on the drive shaft of the motor. "Both designs with integrated bearings are now patent pending and are already being used by the first e-drive designers", reports Thomas Heubach. In both cases, it is also conceivable to use the free space gained thanks to the elimination of the rolling bearing assemblies for a track widening of the freewheels – which can increase their torque capacities.

Rapid realization of customer requests

RINGSPANN attaches great importance to the fact that the design of all four e-drive freewheels basically offers many possibilities for customer- and application-specific modifications and special designs. In combination with the company's consulting expertise and high process efficiency, the use of modern 3D printers in prototyping and the operation of its own freewheel test benches, this ensures that innovative approaches and new developments quickly find their way into practical implementation at the customer's site. <<

„All functional elements of our cage freewheels for e-bike drives meet the highest quality standards and are optimally matched to each other.“



Thomas Heubach
Head of Division Freewheels
at RINGSPANN GmbH