

Industrial Brakes

Brake Calipers • Clamping Units

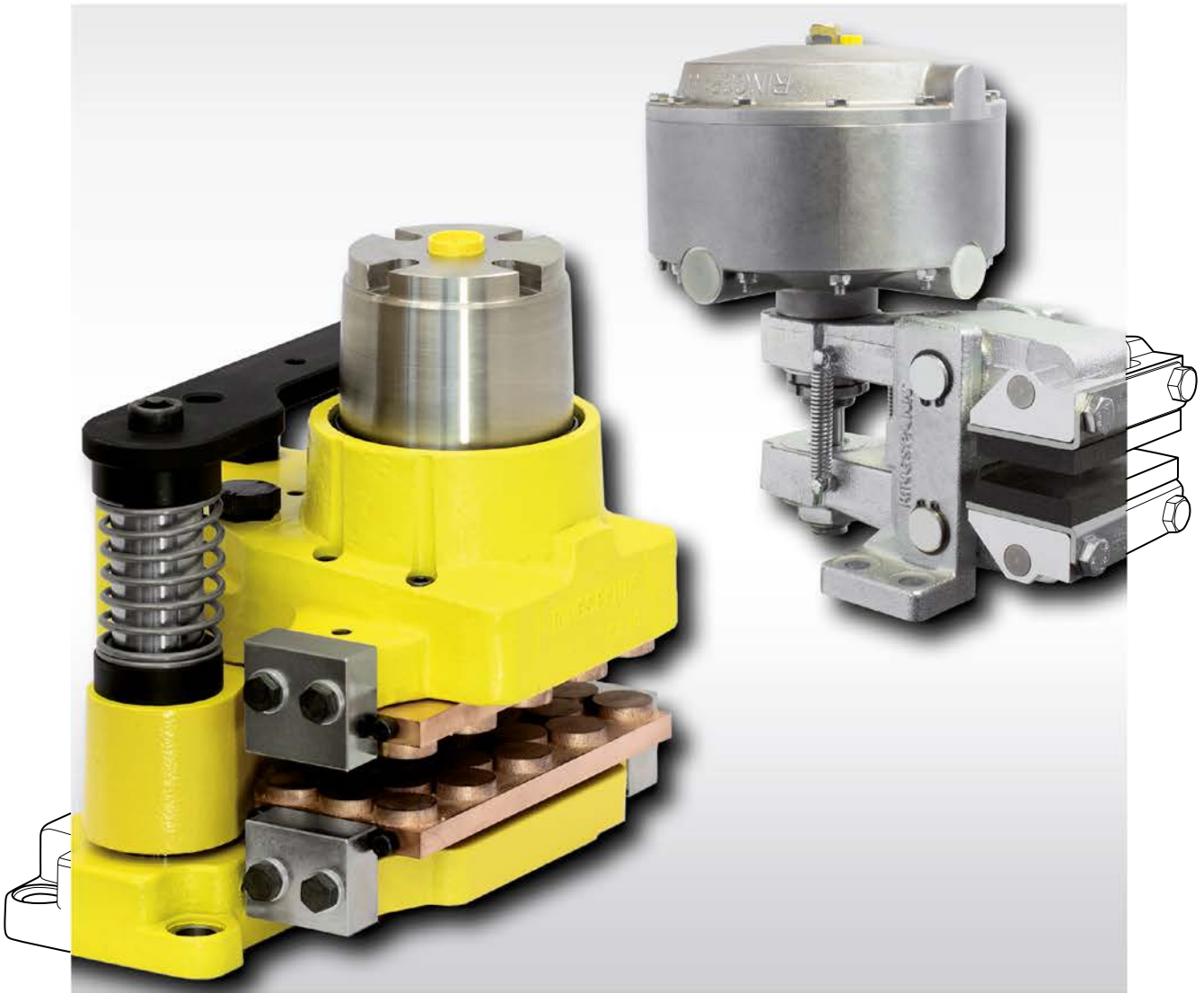

Edition 2025/2026



Table of Contents 1/2

Brake Technology Introduction										Page	
Design and Function of Brakes										6	
Areas of Application for Brakes										7	
Type	Design: S = Disc Brake	Braking torque* [Nm]					Type of mounting brake at machine		Adjustment in case of friction block wear		Page
		10 ²	10 ³	10 ⁴	10 ⁵	10 ⁶	Parallel to brake disc	At right angles to brake disc	Manual	Auto- matic	
Brake Calipers spring activated – pneumatically released											
DH 010 FPM	S			10 - 50				●	●	9	
DV 020 FPM / DH 020 FPM	S		97 - 650				●	●	●	10	
DH 025 FPM	S		240 - 1900					●	●	12	
DH 025 FPA	S		150 - 1700					●	●	14	
DV 030 FPM / DH 030 FPM	S		270 - 2500				●	●	●	16	
DV 030 FPA / DH 030 FPA	S		150 - 2500				●	●	●	20	
DV 035 FPM / DH 035 FPM	S		430 - 5750				●	●	●	24	
DV 035 FPA / DH 035 FPA	S		230 - 5450				●	●	●	28	
DU 060 FPM	S		2700 - 38500				●	●	●	32	
Brake Calipers spring activated – hydraulically released											
DV 020 FHM / DH 020 FHM	S		200 - 650				●	●	●	34	
DV 030 FHM / DH 030 FHM	S		620 - 2000				●	●	●	36	
DV 030 FHA / DH 030 FHA	S		620 - 2000				●	●	●	38	
DV 035 FHM / DH 035 FHM	S		1500 - 4700				●	●	●	40	
DV 035 FHA / DH 035 FHA	S		1500 - 4700				●	●	●	42	
DU 060 FHM	S		2700 - 38500				●	●	●	44	
Brake Calipers spring activated – manually released											
DV 020 FKM / DH 020 FKM	S		160 - 510				●	●	●	46	
Brake Calipers pneumatically activated – spring released											
DH 005 PFK	S	0,5 - 15						●		49	
DH 010 PFK	S	3 - 80						●		50	
DH 015 PFK	S	17 - 430						●		51	
DV 020 PFK / DH 020 PFK	S	25 - 650					●	●		52	
DH 025 PFM	S	55 - 2600						●	●	54	
DV 030 PFM / DH 030 PFM	S	55 - 2600					●	●	●	56	
DV 035 PFM / DH 035 PFM	S	89 - 5100					●	●	●	60	
DU 060 PFM	S	371 - 26900					●	●	●	64	
Brake Calipers manually activated – manually released											
DH 010 MSM	S	20 - 75						●	●	67	
DV 020 MSM / DH 020 MSM	S	160 - 520					●	●	●	68	
DV 020 MKM / DH 020 MKM	S	20 - 600					●	●	●	70	
Brake Calipers spring activated – electromagnetically released											
DH 012 FEM	S	110 - 340						●	●	72	
DV 020 FEM	S	190 - 630					●		●	73	
EV 018 FEM / EH 018 FEM	S	100 - 400					●	●	●	74	
EV 024 FEM / EH 024 FEM	S	400 - 1160					●	●	●	76	
EV 028 FEM / EH 028 FEM	S	940 - 2580					●	●	●	78	
EV 038 FEM / EH 038 FEM	S	2830 - 6590					●	●	●	80	
Brake Calipers electromagnetically activated – spring released											
EV 018 EFM / EH 018 EFM	S	100 - 400					●	●	●	82	
EV 024 EFM / EH 024 EFM	S	440 - 1270					●	●	●	84	
EV 028 EFM / EH 028 EFM	S	1170 - 3220					●	●	●	86	
EV 038 EFM / EH 038 EFM	S	3400 - 7910					●	●	●	88	

* The braking torques relate to the standard brake discs shown in this catalogue. Higher braking torques are possible by the use of several brake calipers or larger brake disc diameters.

Type	Design: S, X = Disc Brake T = Drum Brake R = Rail Brake	Braking torque* [Nm]					Type of mounting brake at machine		Adjustment in case of friction block wear		Page
		10 ²	10 ³	10 ⁴	10 ⁵	10 ⁶	Parallel to brake disc**	At right angles to brake disc**	Manual	Auto- matic	
Brake Calipers spring activated – hydraulically released											
HS 075 FHM	S	1 500 - 40 500					●		●		90
HW 075 FHM	S	1 500 - 40 500					●		●		92
HS 120 FHM	S	8 400 - 182 400					●		●		94
HW 120 FHM	S	8 400 - 182 400					●		●		96
HS 145 FHM-270 ... - ...	S	54 900 - 403 200					●	●	●		98
HW 145 FHM	S	54 900 - 403 200					●		●		102
HS 165 FHM-420 ... - ...	S	97 700 - 631 000					●	●	●		104
HW 165 FHM	S	97 700 - 631 000					●		●		108
HS 215 FHM-560 ... - ...	S	164 400 - 831 100					●	●	●		110
HW 215 FHM	S	164 400 - 831 100					●		●		114
Brake Calipers hydraulically activated – non-releasing											
HI 180 HUK	S	15 230 - 325 000					●				116
HW 180 HUK	S	15 230 - 325 000					●				118
Brake Calipers hydraulically activated – spring released											
HW 040 HFA	S	84 - 1 200					●			●	120
HW 063 HFA	S	320 - 4 700					●			●	121
HS 075 HFK	S	740 - 40 500					●				122
HW 075 HFK	S	740 - 40 500					●				124
HW 100 HFA	S	1 300 - 18 400					●			●	126
HS 120 HFK	S	4 400 - 197 600					●				128
HW 120 HFK	S	4 400 - 197 600					●				130
HW 180 HFA	S	10 000 - 153 500					●			●	132
Brake Calipers spring activated – electrohydraulically released											
DS 160 FEA	S	200 - 600								●	134
DS 230 FEM / DS 230 FEA	S	250 - 1 600							●	●	136
DX 230 FEA	S	400 - 6 200								●	140
DS 280 FEM / DS 280 FEA	S	1 200 - 8 100							●	●	142
DX 280 FEA	S	1 400 - 28 100								●	146
DS 370 FEM / DS 370 FEA	S	2 950 - 22 400							●	●	148
Brake Calipers spring activated – electrohydraulically released											
DT 200 FE ... NC	T	230 - 310							●	●	152
DT 200 FEA ... ST	T	250 - 330								●	156
DT 250 FE ... NC	T	260 - 700							●	●	158
DT 250 FEA ... ST	T	300 - 750								●	162
DT 315 FE ... NC	T	285 - 1 700							●	●	164
DT 315 FEA ... ST	T	350 - 1 800								●	168
DT 400 FE ... NC	T	525 - 2 075							●	●	170
DT 400 FEA ... ST	T	680 - 2 500								●	174
DT 500 FE ... NC	T	2 500 - 4 170							●	●	176
DT 500 FEA ... ST	T	1 600 - 5 120								●	180
DT 630 FEA ... ST	T	3 100 - 7 200								●	182
Rail Brake spring activated – hydraulically released											
HR 130 FHK	R	110 000						●			184
HR 185 FHK	R	300 000					●				186
Rail Clamp spring activated – hydraulically released											
DR 085 FHK	R	400 000						●			188
DR 088 FHK	R	500 000						●			190
Clamping Units spring activated – hydraulically or pneumatically released											
KE ... FHK											204
KE ... FPK											206

* The braking torques relate to the standard brake discs shown in this catalogue. Higher braking torques are possible by the use of several brake calipers or larger brake disc diameters.

** Parallel or at right angles to the rail - *** Specified in braking force [N]

Table of Contents 2/2

							
DH 010 FPM	DV 020 FPM / DH 020 FPM	DH 025 FPM	DH 025 FPA	DV 030 FPM / DH 030 FPM	DV 030 FPA / DH 030 FPA	DV 035 FPM / DH 035 FPM	DV 035 FPA / DH 035 FPA
							
DU 060 FPM	DV 020 FHM / DH 020 FHM	DV 030 FHM / DH 030 FHM	DV 030 FHA / DH 030 FHA	DV 035 FHM / DH 035 FHM	DV 035 FHA / DH 035 FHA	DU 060 FHM	DV 020 FKM / DH 020 FKM
							
DH 005 PFK	DH 010 PFK	DH 015 PFK	DV 020 PFK / DH 020 PFK	DH 025 PFM	DV 030 PFM / DH 030 PFM	DV 035 PFM / DH 035 PFM	DU 060 PFM
							
DH 010 MSM	DV 020 MSM / DH 020 MSM	DV 020 MKM / DH 020 MKM	DH 012 FEM	DV 020 FEM	EV 018 FEM / EH 018 FEM	EV 024 FEM / EH 024 FEM	EV 028 FEM / EH 028 FEM
							
EV 038 FEM / EH 038 FEM	EV 018 EFM / EH 018 EFM	EV 024 EFM / EH 024 EFM	EV 028 EFM / EH 028 EFM	EV 038 EFM / EH 038 EFM			
							
HS 075 FHM	HW 075 FHM	HS 120 FHM	HW 120 FHM	HS 145 FHM-270 R-V	HS 145 FHM-270 ... -H	HW 145 FHM	HS 165 FHM-420 R-V
							
HS 165 FHM-420 ... -H	HW 165 FHM	HS 215 FHM-560 R-V	HS 215 FHM-560 ... -H	HW 215 FHM	HI 180 HUK	HW 180 HUK	
							
HW 040 HFA	HW 063 HFA	HS 075 HFK	HW 075 HFK	HW 100 HFA	HS 120 HFK	HW 120 HFK	HW 180 HFA
							
DS ... FEM / DS ... FEA	DX ... FEA	DT ... FEM ... NC / DT ... FEA ... NC	DT ... FEA ... ST	HR 130 FHK	HR 185 FHK	DR 085 FHK	DR 088 FHK

Brake Calipers Accessories		Page
Brake Discs		192
Friction Block Wear Control		196
Universal Transformer		196
RCS® Pull Cable		197
RCS® Hand Brake Lever		197
Control System BCS 600		198
Hydraulic Power Unit		202
Pneumatic Cabinet		202



Brake Technology Details		Page
Technical Points Brake Discs		195
Technical Points Brake Calipers		208
Technical Points Clamping Units		209
Questionnaire for selecting Brake Calipers and Questionnaire for selecting Clamping Units		210

Online Calculation Tool Brakes at www.ringspann.com

The RINGSPANN Calculation Tool has been developed to work out the right and time-efficient dimensioning of an optimal brake.

- Calculation Tool for the calculation of braking torque or braking force during deceleration, control and holding
- Mass calculation of simple bodies
- Moment of Inertia
- Downloading of relevant product information
- Downloading of CAD models



No Drives without Disc Brakes

For a long time now Disc Brakes have been tried and tested in the aviation and automotive industry, and increasing awareness of opera-

tional safety and ever stricter rules on accident prevention have made them indispensable. After all, wherever there is acceleration, there

must also be braking. A reliable and economic solution to these problems are RINGSPANN Disc Brakes.

Advantages of RINGSPANN Disc Brakes

The following features make the RINGSPANN Disc Brakes unique:

- The well thought-out design of RINGSPANN Disc Brakes permits a **simple and space-saving arrangement**, even in existing installations.
- The open design of the RINGSPANN Disc Brakes with their excellent ventilation characteristics provides **ideal heat dissipation**; this is a precondition for high braking power with a compact design.

- Highly wear-resistant friction material and large braking surfaces ensure long intervals between maintenance. The practical and robust design of RINGSPANN Disc Brakes makes that **maintenance easy and uncomplicated**. The friction pads are easily replaced without the need to remove the brake.

- RINGSPANN Disc Brakes are fitted with **swivel mounted friction blocks**; this ensures that the friction blocks are always in full face contact with the brake disc. When the brake is released, the friction blocks are lifted safely off the disc by a spring, irrespective of the installation arrangement.

For each Application the right Solution

RINGSPANN Disc Brakes require minimal installation space. Brake Calipers or Brake Saddles may be arranged in any position on brake discs of varying diameters. By using several Brake Calipers on the same disc it is possible to increase the braking torque without the need to enlarge the installation space.

The universal concept of the RINGSPANN Disc Brake fulfils various functions:

- **Stopping brake**
- **Control brake**
- **Holding brake**

As a **stopping brake**, it brings a rotating shaft to a standstill in a short time, for example during a power failure or an emergency stop.

As a **control brake**, it effectively maintains material tension.

As a **holding brake**, it prevents the unintended start of a stationary shaft.

The Product Range

RINGSPANN offers a comprehensive range of Disc Brakes:

- **Spring activated Brake Calipers**; release is either pneumatic, hydraulic, electromagnetic or manual by means of a pull cable

- **Pneumatically activated Brake Calipers**; spring released

- **Manually activated Brake Calipers**; manually released with a hand wheel or a pull cable

- **Hydraulically activated Brake Calipers**; spring released

- **Spring activated Clamping Unit**; hydraulically or pneumatically released

Accessories

Accessories are available for special applications:

- Two standard types of **brake discs** are available with diameters ranging from 125 mm up to 1 000 mm

- All brakes can be supplied with an **electric indicator for friction block wear**

- Inductive proximity switches for **monitoring the operating condition** "brake released" are available

- To prolong the operating life, **friction blocks with double the friction surface** are available for Brake Calipers sizes 12, 15, 20 and 30

- **Special friction linings** are available for special requirements

Amusement rides

Assembly stations

Belt conveyors

Construction machines

Cranes

Drive units

Elevators and escalators

Extruder, machines for rubber and plastics

Fans and ventilators

Foundry machines

Machines for food industry

Packaging machines

Paper machines

Printing machines

Ship drives

Shredders

Steel mills

Stranding lines

Test benches

Textile machines

Wind turbines

Wire and tube machines

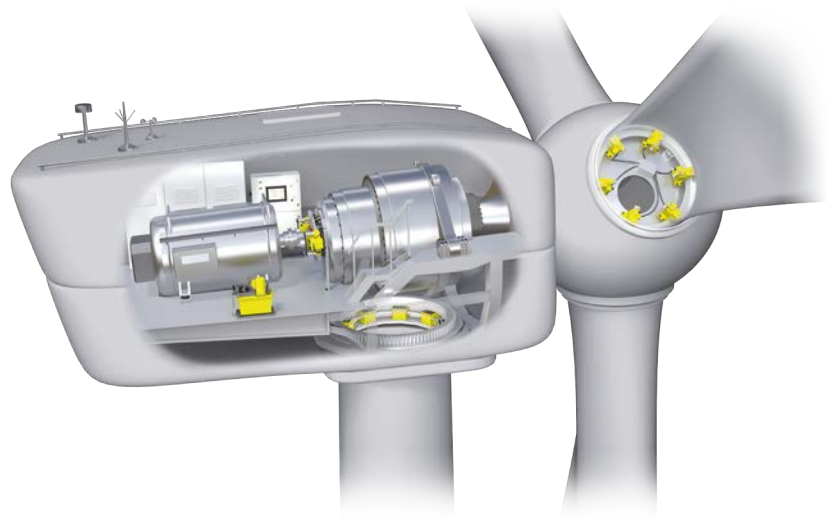

Wind turbines

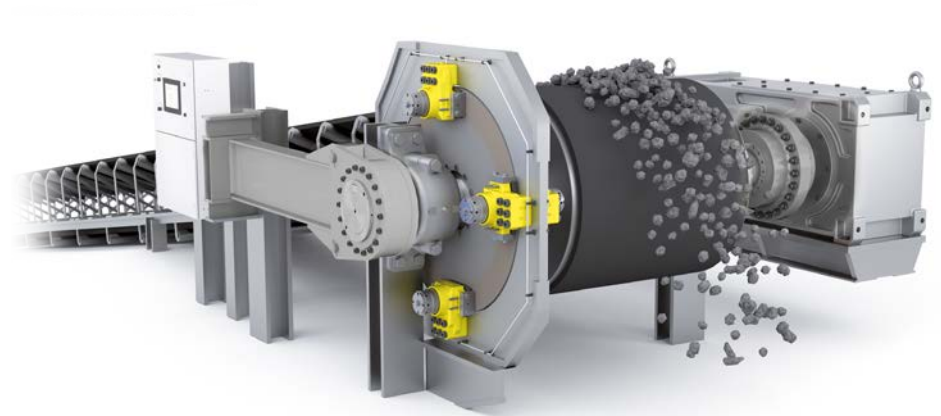

Belt conveyors

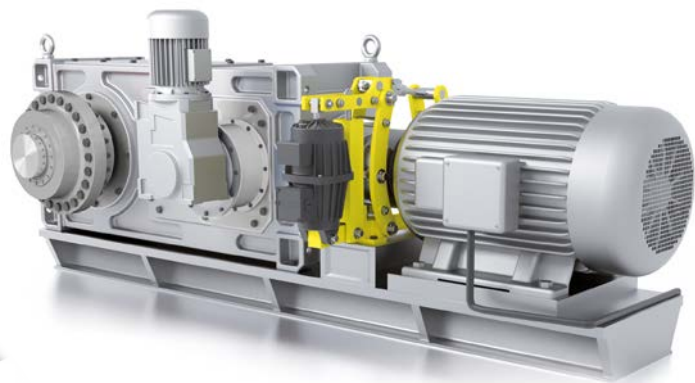

Drive units

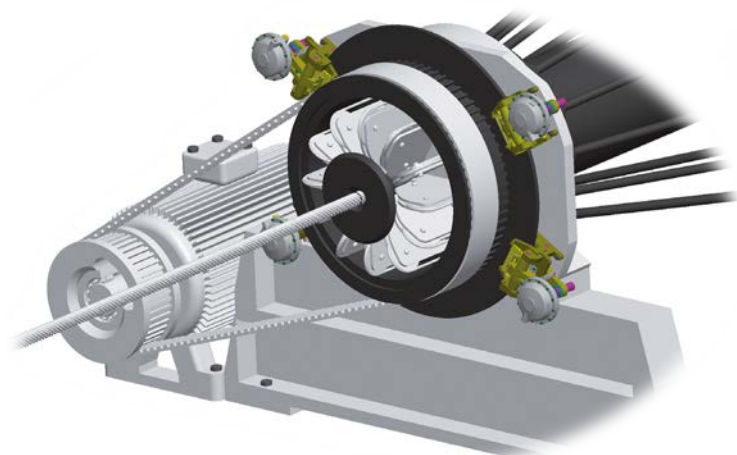

Stranding lines

Brake Caliper DH 010 FPM

spring activated – pneumatically released



Features

Features	Code
Brake Caliper	D
Mounting to the machine at right angles to the brake disc	H
Frame size 010	010
Spring activated	F
Pneumatically released	P
Manual adjustment to accommodate friction block wear	M
Designs 010 or 012 are available	010 012
Piston mounted in central position	M
Thickness of brake disc 12,5 mm	12

Example for ordering

Brake Caliper DH 010 FPM, design 010, piston mounted in central position, thickness of brake disc 12,5 mm:

DH 010 FPM - 010 M - 12

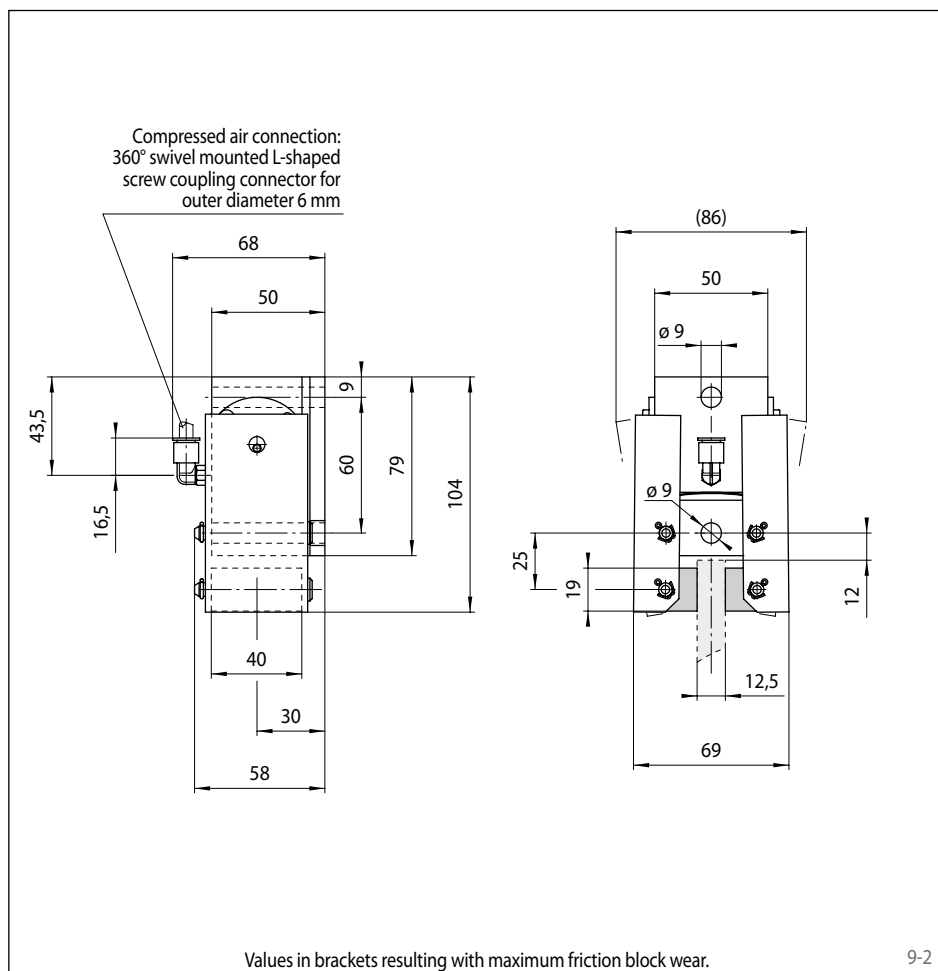

Technical Data

Brake disc diameter mm	Brake Caliper DH 010 FPM	
	with design 010 Braking torque Nm	with design 012 Braking torque Nm
125	10	15
150	14	19
200	20	26
250	26	34
300	32	41
355	38	50
Clamping force	290 N	375 N
Air pressure	min. 4 bar max. 8 bar	min. 5 bar max. 8 bar
Air volume per activation	max. 3 cm ³	max. 3 cm ³
Weight	1 kg	1 kg

The braking torques shown in the table are based on a theoretical friction coefficient of 0,4.

Brake Caliper DV 020 FPM

spring activated – pneumatically released



Features

Features	Code
Brake Caliper	D
Mounting to the machine parallel to the brake disc	V
Frame size 020	020
Spring activated	F
Pneumatically released	P
Manual adjustment to accommodate friction block wear	M
Thrusters 020, 030 or 040 are available	020 030 040
Thruster mounted right or left available	R L
Thickness of brake disc 12,5 mm	12

Example for ordering

Brake Caliper DV 020 FPM, thruster 020, thruster mounted right, thickness of brake disc 12,5 mm:

DV 020 FPM - 020 R - 12

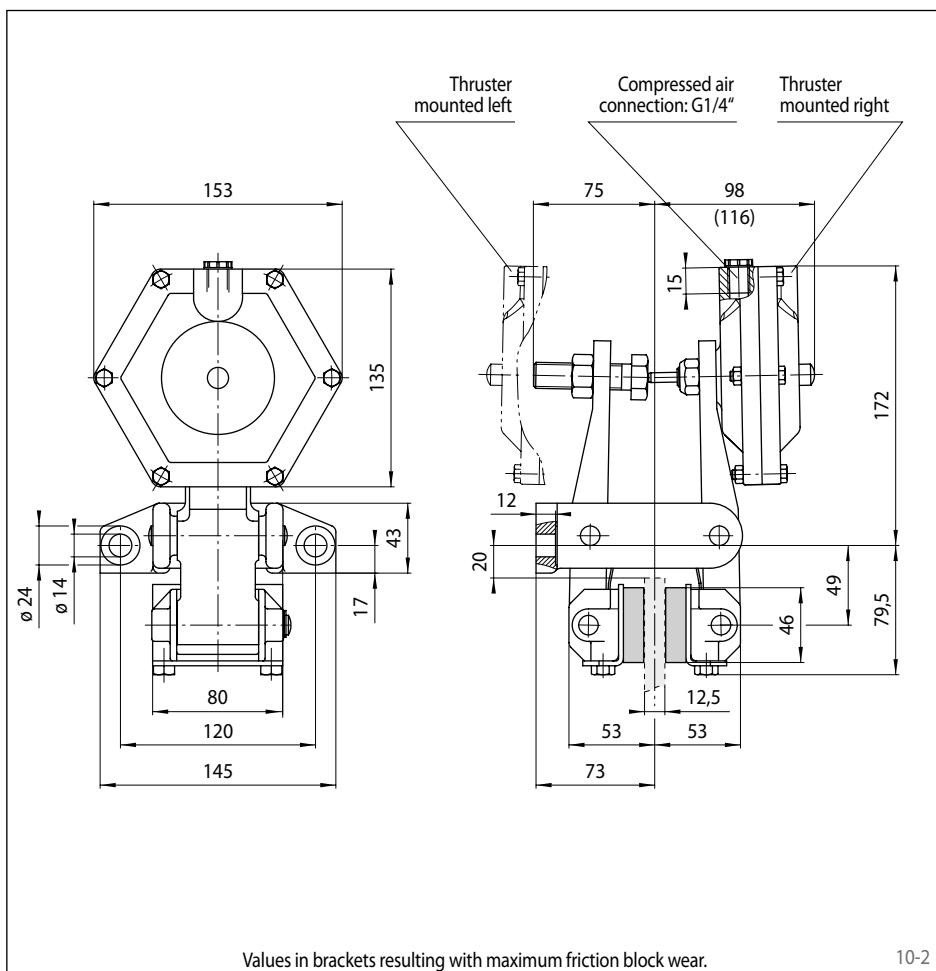

Technical Data

	Brake Caliper DV 020 FPM		
	with thruster 020	with thruster 030	with thruster 040
Brake disc diameter	Braking torque	Braking torque	Braking torque
mm	Nm	Nm	Nm
200	97	130	200
250	130	180	270
300	170	220	340
355	200	270	420
430	250	340	520
520	310	430	650
Clamping force	1700 N	2300 N	3500 N
Air pressure	min. 2,6 bar max. 7 bar	min. 3,5 bar max. 7 bar	min. 5 bar max. 7 bar
Air volume per activation	max. 17 cm ³	max. 17 cm ³	max. 17 cm ³
Weight	5,2 kg	5,2 kg	5,2 kg

The braking torques shown in the table are based on a theoretical friction coefficient of 0,4.

Brake Caliper DH 020 FPM

spring activated – pneumatically released



11-1

Features	Code
Brake Caliper	D
Mounting to the machine at right angles to the brake disc	H
Frame size 020	020
Spring activated	F
Pneumatically released	P
Manual adjustment to accommodate friction block wear	M
Thrusters 020, 030 or 040 are available	020 030 040
Position of the thruster to the right or left can be defined by turning the brake during installation	U
Thickness of brake disc 12,5 mm	12

Example for ordering

Brake Caliper DH 020 FPM, thruster 020, position of the thruster can be to the right or left, thickness of brake disc 12,5 mm:

DH 020 FPM - 020 U - 12

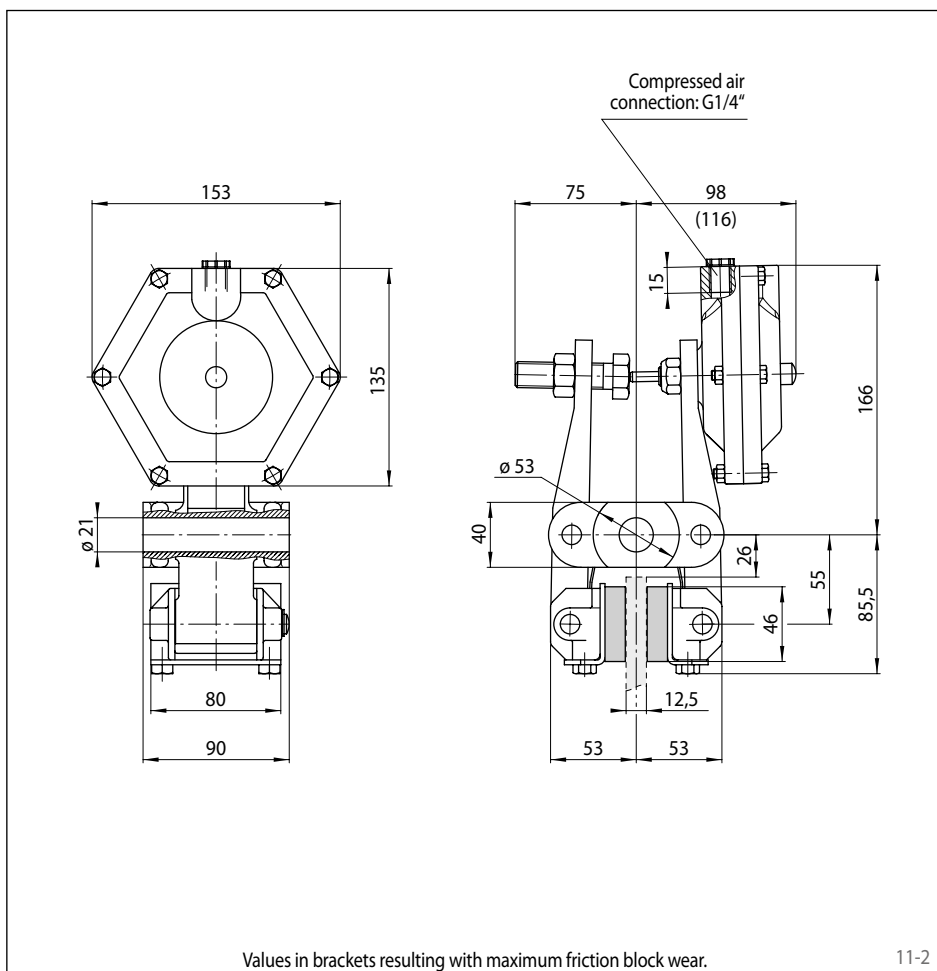

Values in brackets resulting with maximum friction block wear.

11-2

Technical Data

Brake disc diameter	Brake Caliper DH 020 FPM		
	with thruster 020	with thruster 030	with thruster 040
mm	Braking torque Nm	Braking torque Nm	Braking torque Nm
200	97	130	200
250	130	180	270
300	170	220	340
355	200	270	420
430	250	340	520
520	310	430	650
Clamping force	1700 N	2300 N	3500 N
Air pressure	min. 2,6 bar max. 7 bar	min. 3,5 bar max. 7 bar	min. 5 bar max. 7 bar
Air volume per activation	max. 17 cm ³	max. 17 cm ³	max. 17 cm ³
Weight	5,2 kg	5,2 kg	5,2 kg

The braking torques shown in the table are based on a theoretical friction coefficient of 0,4.

Brake Caliper DH 025 FPM

spring activated – pneumatically released

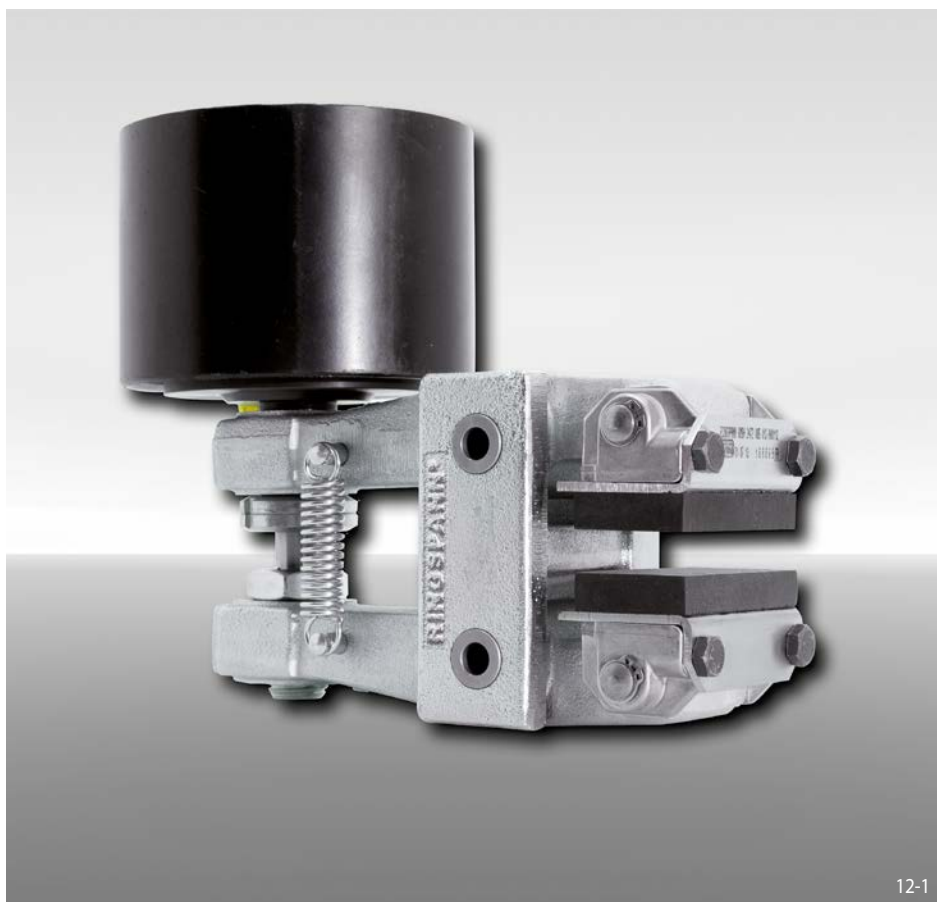

Features	Code
Brake Caliper	D
Mounting to the machine at right angles to the brake disc	H
Frame size 025	025
Spring activated	F
Pneumatically released	P
Manual adjustment to accommodate friction block wear	M
Thrusters 015, 025, 035 or 045 are available	015 to 045
Thruster mounted right or left available	R L
Thickness of brake disc 12,5 mm or 25 mm	12 25

Example for ordering

Brake Caliper DH 025 FPM, thruster 015, thruster mounted right, thickness of brake disc 12,5 mm:

DH 025 FPM - 015 R - 12

Technical Data

	Brake Caliper DH 025 FPM			
	with thruster 015	with thruster 025	with thruster 035	with thruster 045
Brake disc diameter	Braking torque	Braking torque	Braking torque	Braking torque
mm	Nm	Nm	Nm	Nm
200	240	270	400	570
250	330	370	540	770
300	420	460	680	970
355	510	570	840	1200
430	640	710	1050	1500
520	790	890	1300	1900
Clamping force	4300 N	4800 N	7100 N	10100 N
Air pressure	min. 5 bar max. 7 bar	min. 5 bar max. 8 bar	min. 4,2 bar max. 8 bar	min. 5 bar max. 8 bar
Air volume per activation	max. 17 cm ³	max. 120 cm ³	max. 185 cm ³	max. 185 cm ³
Weight	7,5 kg	8,6 kg	10,9 kg	11,0 kg

The braking torques shown in the table are based on a theoretical friction coefficient of 0,4.

Brake Caliper DH 025 FPM

spring activated – pneumatically released

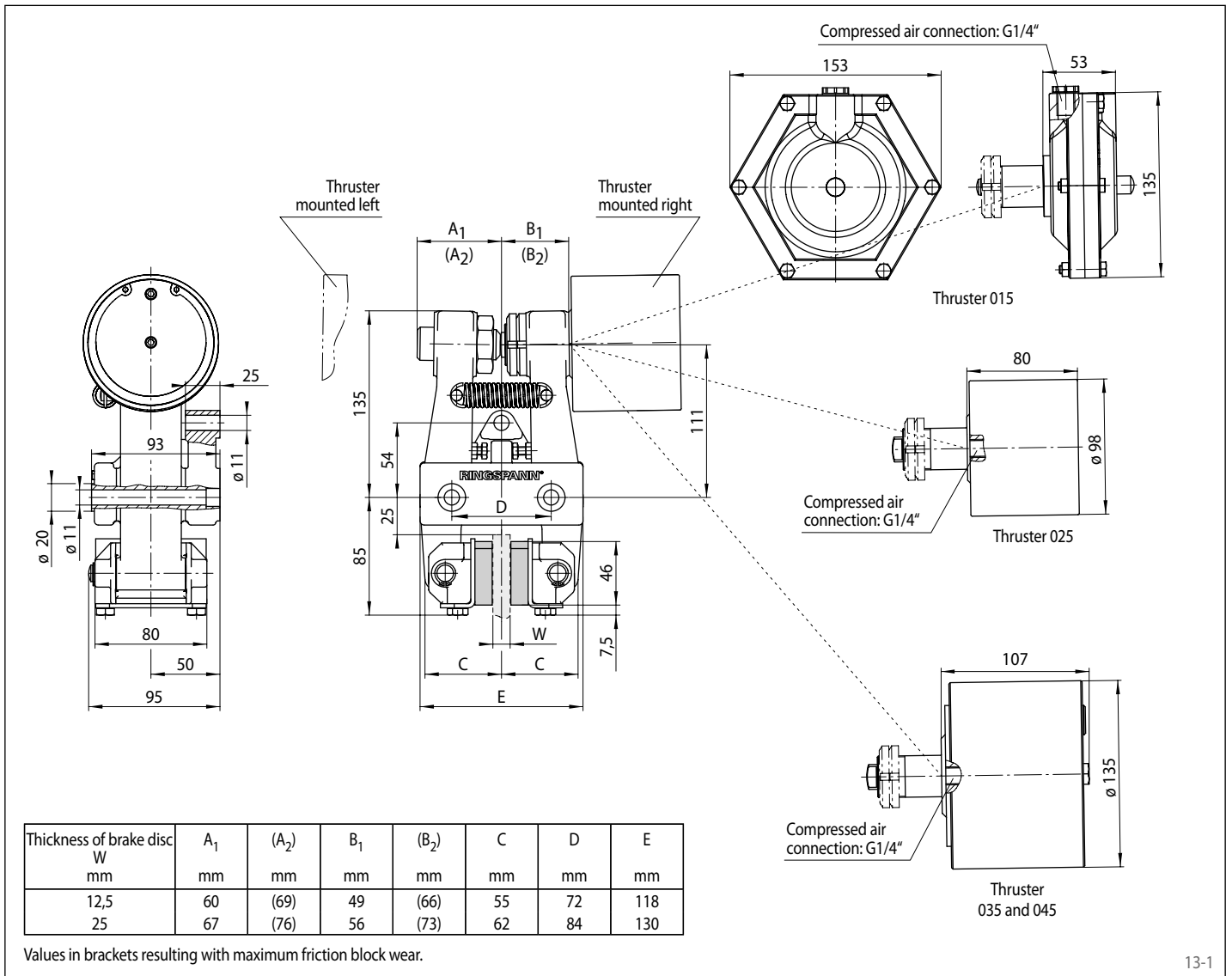

Brake Caliper DH 025 FPA

spring activated – pneumatically released

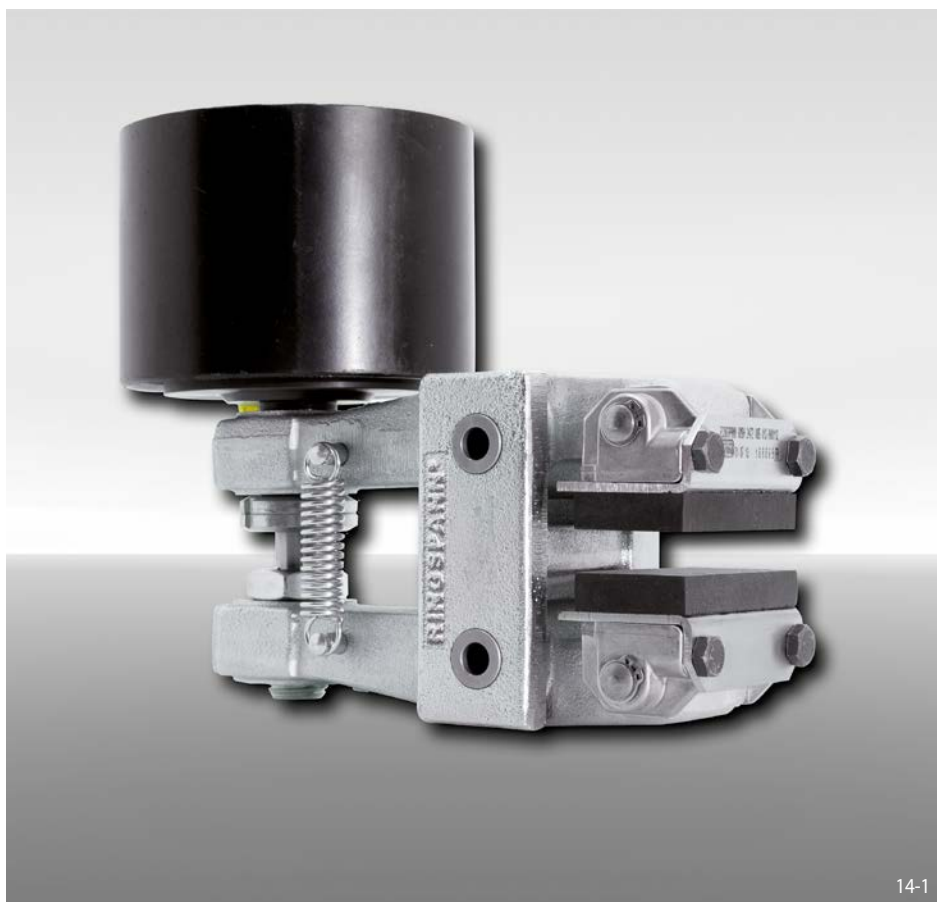

Features

Features	Code
Brake Caliper	D
Mounting to the machine at right angles to the brake disc	H
Frame size 025	025
Spring activated	F
Pneumatically released	P
Automatic adjustment to accommodate friction block wear	A
Thrusters 065, 085 or 095 are available	065 to 095
Thruster mounted right or left available	R L
Thickness of brake disc 12,5 mm or 25 mm	12 25

Example for ordering

Brake Caliper DH 025 FPA, thruster 085, thruster mounted right, thickness of brake disc 12,5 mm:

DH 025 FPA - 085 R - 12

Technical Data

	Brake Caliper DH 025 FPA		
	with thruster 065	with thruster 085	with thruster 095
Brake disc diameter	Braking torque	Braking torque	Braking torque
mm	Nm	Nm	Nm
200	250	150	530
250	340	200	710
300	430	250	900
355	530	310	1 100
430	670	390	1 400
520	830	480	1 700
Clamping force	4 500 N	2 600 N	9 300 N
Air pressure	min. 5 bar max. 8 bar	min. 1,7 bar max. 8 bar	min. 5 bar max. 8 bar
Air volume per activation	max. 72 cm ³	max. 140 cm ³	max. 140 cm ³
Weight	8,9 kg	11,2 kg	11,2 kg

The braking torques shown in the table are based on a theoretical friction coefficient of 0,4.

Brake Caliper DH 025 FPA

spring activated – pneumatically released

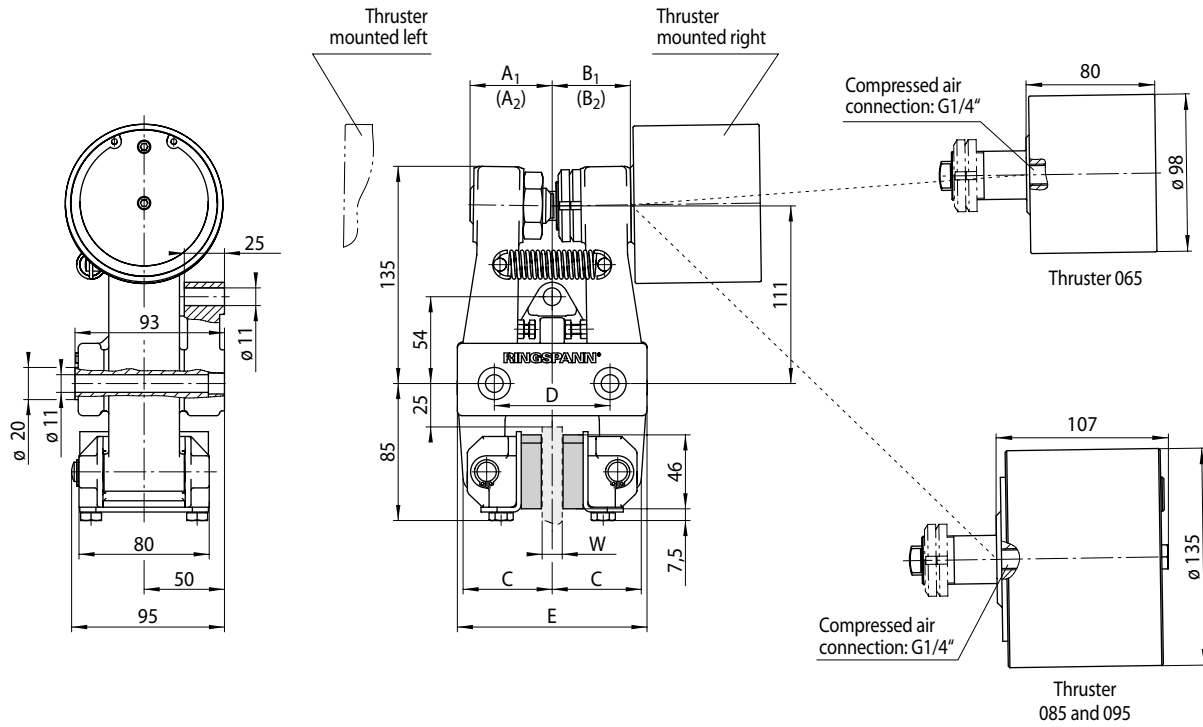

Thickness of brake disc W mm	A ₁ mm	(A ₂) mm	B ₁ mm	(B ₂) mm	C mm	D mm	E mm
12,5	51	(69)	49	(66)	55	72	118
25	57	(76)	56	(73)	62	84	130

Values in brackets resulting with maximum friction block wear.

Brake Caliper DV 030 FPM

spring activated – pneumatically released

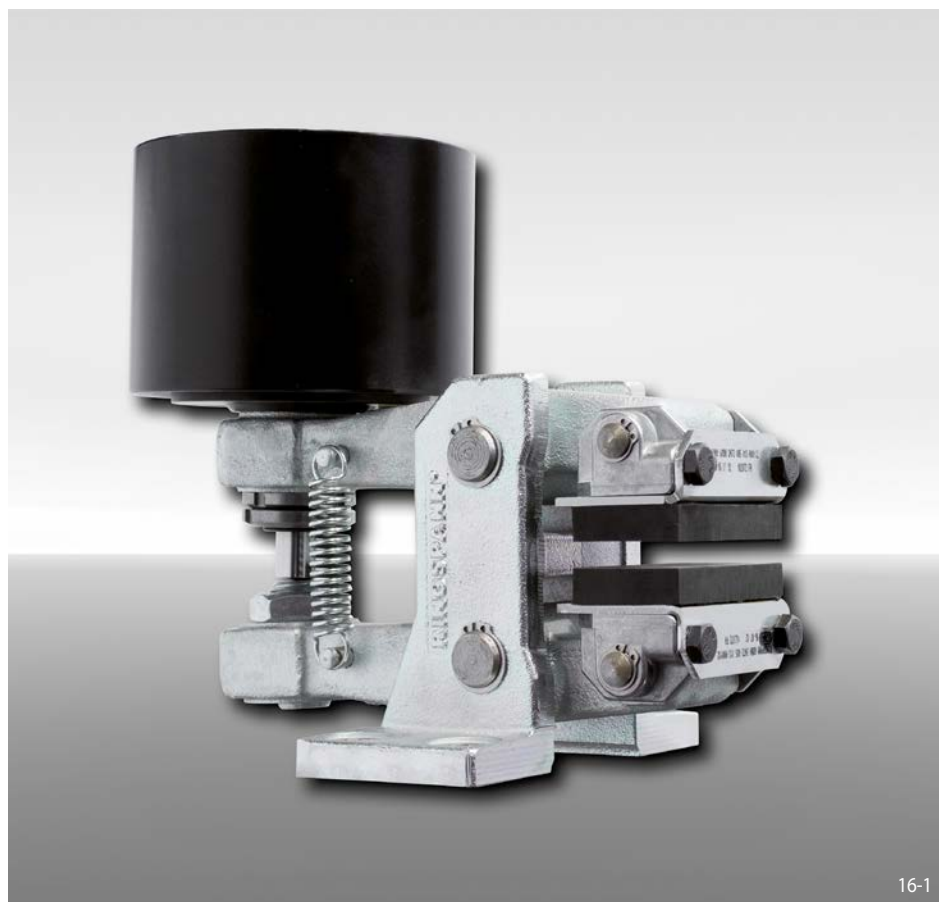

Features	Code
Brake Caliper	D
Mounting to the machine parallel to the brake disc	V
Frame size 030	030
Spring activated	F
Pneumatically released	P
Manual adjustment to accommodate friction block wear	M
Thrusters 025, 035, 045 or 101 are available	025 to 101
Thruster mounted right or left available	R L
Thickness of brake disc 12,5 mm or 25 mm	12 25

Example for ordering

Brake Caliper DV 030 FPM, thruster 035, thruster mounted right, thickness of brake disc 12,5 mm:

DV 030 FPM - 035 R - 12

Technical Data

	Brake Caliper DV 030 FPM			
	with thruster 025	with thruster 035	with thruster 045	with thruster 101
Brake disc diameter	Braking torque	Braking torque	Braking torque	Braking torque
mm	Nm	Nm	Nm	Nm
200	270	400	570	760
250	370	540	770	1050
300	460	680	970	1300
355	570	840	1200	1600
430	710	1050	1500	2000
520	890	1300	1900	2500
Arrangement	right / left	right / left	right / left	right
Clamping force	4800 N	7100 N	10100 N	13500 N
Air pressure	min. 5 bar max. 8 bar	min. 4,2 bar max. 8 bar	min. 5 bar max. 8 bar	min. 4,5 bar max. 8 bar
Air volume per activation	max. 120 cm ³	max. 185 cm ³	max. 185 cm ³	max. 540 cm ³
Weight	9,1 kg	11,2 kg	11,2 kg	12,4 kg

The braking torques shown in the table are based on a theoretical friction coefficient of 0,4.

Brake Caliper DV 030 FPM

spring activated – pneumatically released

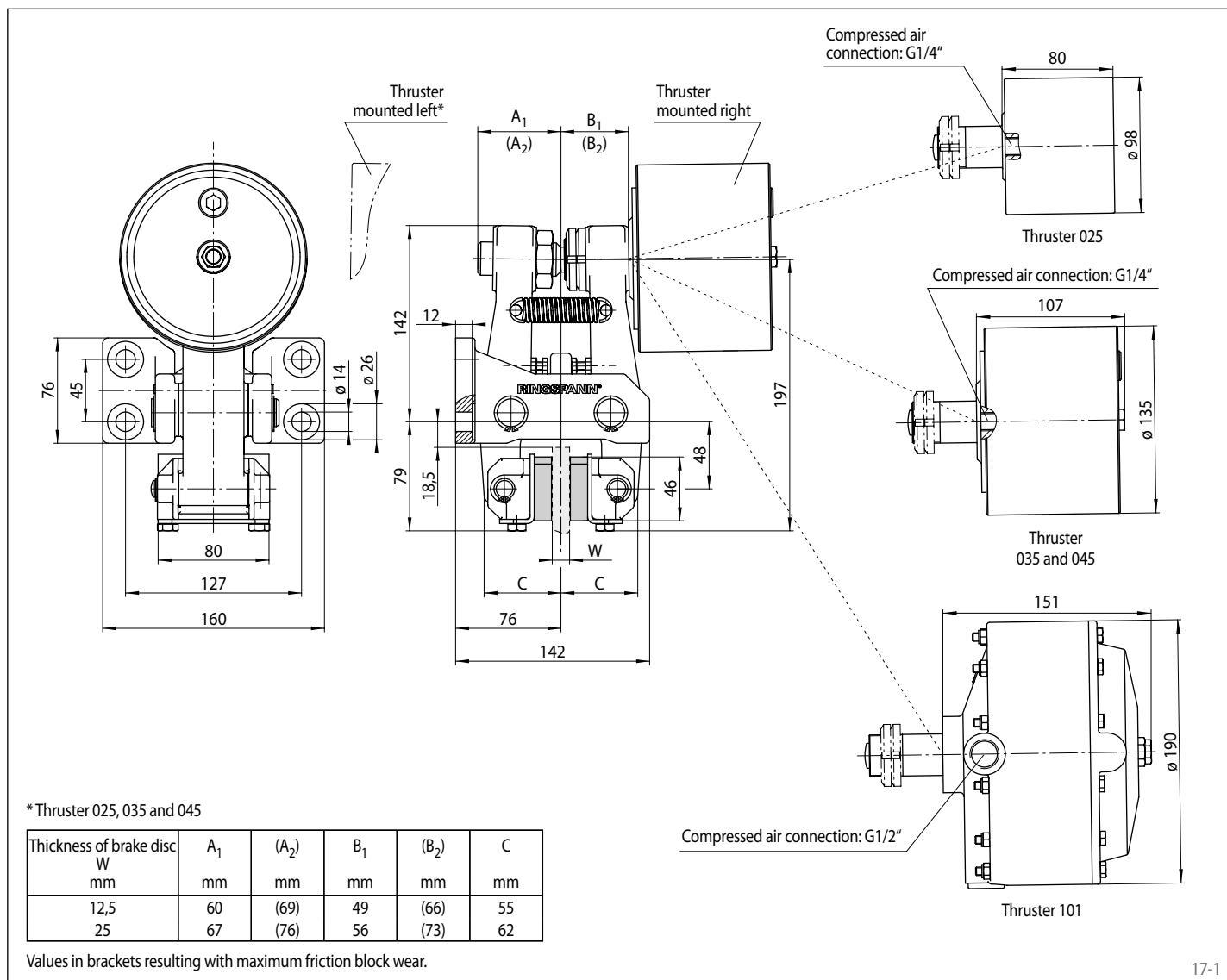

Brake Caliper DH 030 FPM

spring activated – pneumatically released



Features	Code
Brake Caliper	D
Mounting to the machine at right angles to the brake disc	H
Frame size 030	030
Spring activated	F
Pneumatically released	P
Manual adjustment to accommodate friction block wear	M
Thrusters 025, 035, 045 or 101 are available	025 to 101
Thruster mounted right or left available	R L
Thickness of brake disc 12,5 mm or 25 mm	12 25

Example for ordering

Brake Caliper DH 030 FPM, thruster 035, thruster mounted right, thickness of brake disc 12,5 mm:

DH 030 FPM - 035 R - 12

Technical Data

	Brake Caliper DH 030 FPM			
	with thruster 025	with thruster 035	with thruster 045	with thruster 101
Brake disc diameter	Braking torque	Braking torque	Braking torque	Braking torque
mm	Nm	Nm	Nm	Nm
200	270	400	570	760
250	370	540	770	1050
300	460	680	970	1300
355	570	840	1200	1600
430	710	1050	1500	2000
520	890	1300	1900	2500
Clamping force	4800 N	7100 N	10100 N	13500 N
Air pressure	min. 5 bar max. 8 bar	min. 4,2 bar max. 8 bar	min. 5 bar max. 8 bar	min. 4,5 bar max. 8 bar
Air volume per activation	max. 120 cm ³	max. 185 cm ³	max. 185 cm ³	max. 540 cm ³
Weight	9,5 kg	11,6 kg	11,6 kg	12,8 kg

The braking torques shown in the table are based on a theoretical friction coefficient of 0,4.

Brake Caliper DH 030 FPM

spring activated – pneumatically released

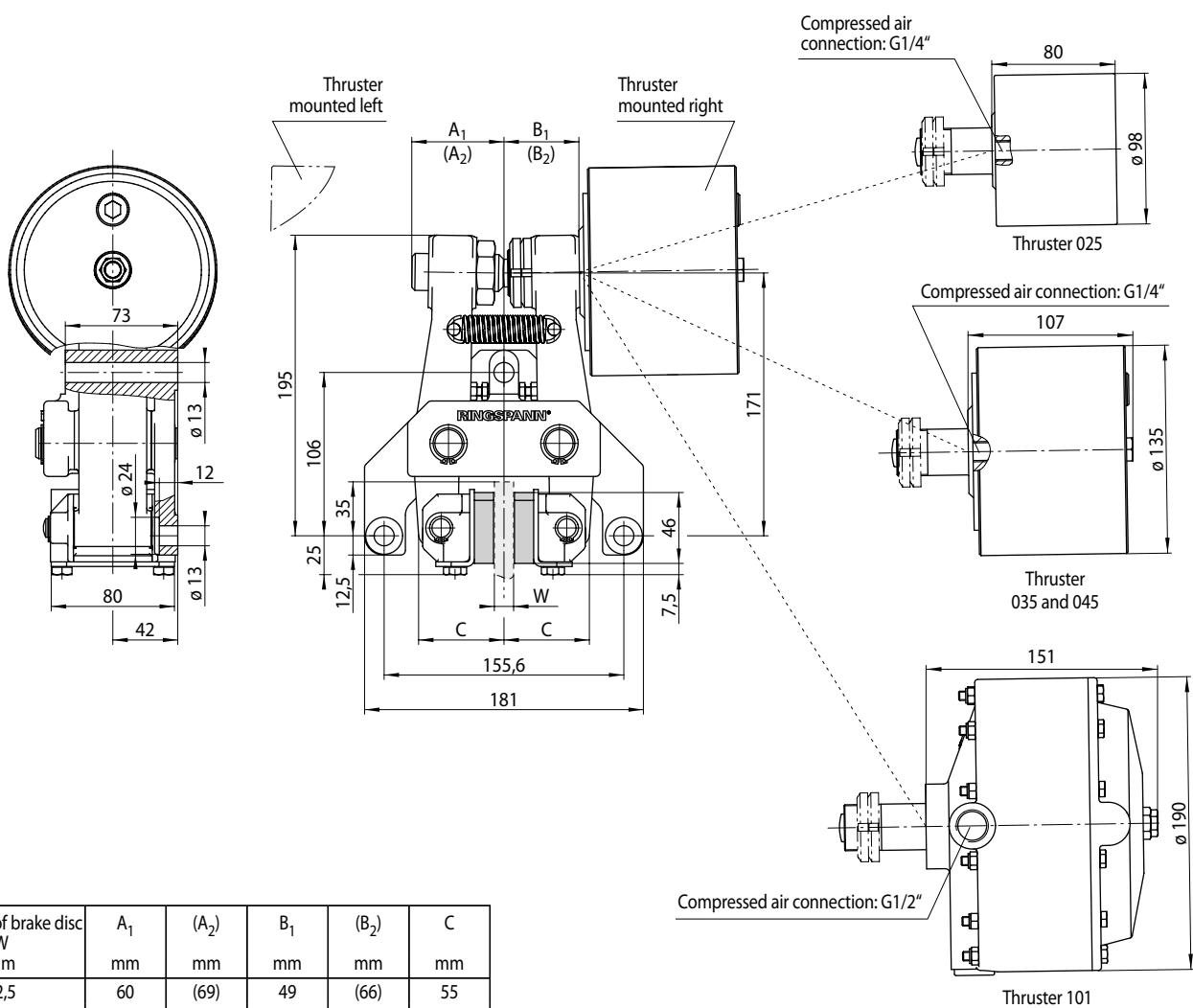

Thickness of brake disc W mm	A ₁ mm	(A ₂) mm	B ₁ mm	(B ₂) mm	C mm
12,5	60	(69)	49	(66)	55
25	67	(76)	56	(73)	62

Values in brackets resulting with maximum friction block wear.

Brake Caliper DV 030 FPA

spring activated – pneumatically released



Features	Code
Brake Caliper	D
Mounting to the machine parallel to the brake disc	V
Frame size 030	030
Spring activated	F
Pneumatically released	P
Automatic adjustment to accommodate friction block wear	A
Thrusters 065, 085, 095 or 105 are available	065 to 105
Thruster mounted right or left available	R L
Thickness of brake disc 12,5 mm or 25 mm	12 25

Example for ordering

Brake Caliper DV 030 FPA, thruster 085, thruster mounted right, thickness of brake disc 12,5 mm:

DV 030 FPA - 085 R - 12

Technical Data

	Brake Caliper DV 030 FPA			
	with thruster 065	with thruster 085	with thruster 095	with thruster 105
Brake disc diameter	Braking torque	Braking torque	Braking torque	Braking torque
mm	Nm	Nm	Nm	Nm
200	250	150	530	760
250	340	200	710	1050
300	430	250	900	1300
355	530	310	1100	1600
430	670	390	1400	2000
520	830	480	1700	2500
Arrangement	right / left	right / left	right / left	right
Clamping force	4500 N	2600 N	9300 N	13500 N
Air pressure	min. 5 bar max. 8 bar	min. 1,7 bar max. 8 bar	min. 5 bar max. 8 bar	min. 4,7 bar max. 8 bar
Air volume per activation	max. 72 cm ³	max. 140 cm ³	max. 140 cm ³	max. 460 cm ³
Weight	9,1 kg	11,5 kg	11,5 kg	13,1 kg

The braking torques shown in the table are based on a theoretical friction coefficient of 0,4.

Brake Caliper DV 030 FPA

spring activated – pneumatically released

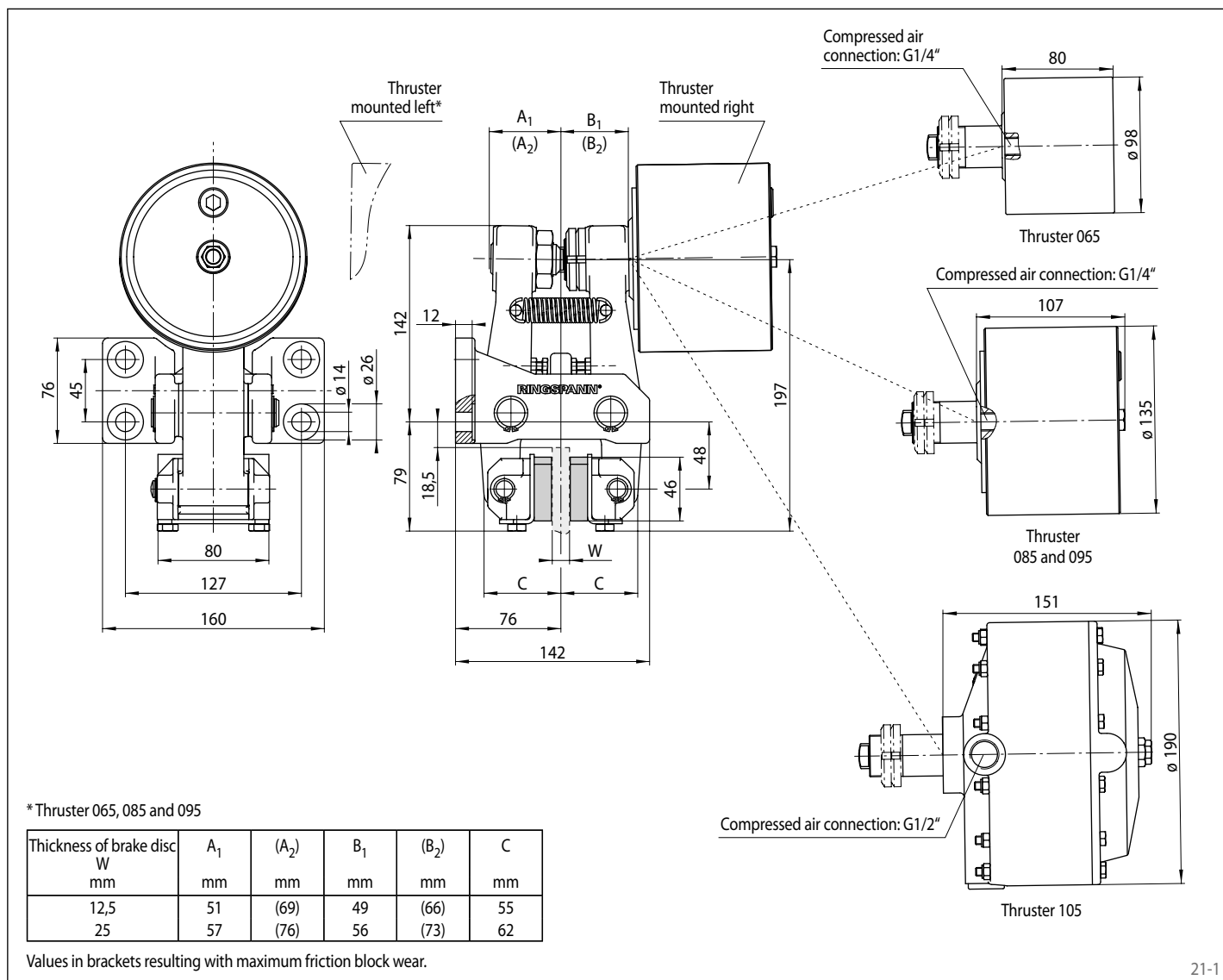

Brake Caliper DH 030 FPA

spring activated – pneumatically released



Features	Code
Brake Caliper	D
Mounting to the machine at right angles to the brake disc	H
Frame size 030	030
Spring activated	F
Pneumatically released	P
Automatic adjustment to accommodate friction block wear	A
Thrusters 065, 085, 095 or 105 are available	065 to 105
Thruster mounted right or left available	R L
Thickness of brake disc 12,5 mm or 25 mm	12 25

Example for ordering

Brake Caliper DH 030 FPA, thruster 085, thruster mounted right, thickness of brake disc 12,5 mm:

DH 030 FPA - 085 R - 12

Technical Data

	Brake Caliper DH 030 FPA			
	with thruster 065	with thruster 085	with thruster 095	with thruster 105
Brake disc diameter	Braking torque	Braking torque	Braking torque	Braking torque
mm	Nm	Nm	Nm	Nm
200	250	150	530	760
250	340	200	710	1050
300	430	250	900	1300
355	530	310	1100	1600
430	670	390	1400	2000
520	830	480	1700	2500
Clamping force	4500 N	2600 N	9300 N	13500 N
Air pressure	min. 5 bar max. 8 bar	min. 1,7 bar max. 8 bar	min. 5 bar max. 8 bar	min. 4,7 bar max. 8 bar
Air volume per activation	max. 72 cm ³	max. 140 cm ³	max. 140 cm ³	max. 460 cm ³
Weight	9,5 kg	11,9 kg	11,9 kg	13,5 kg

The braking torques shown in the table are based on a theoretical friction coefficient of 0,4.

Brake Caliper DH 030 FPA

spring activated – pneumatically released

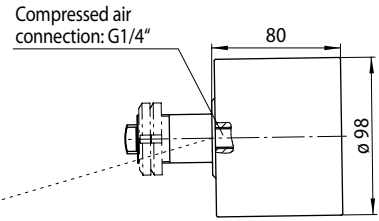
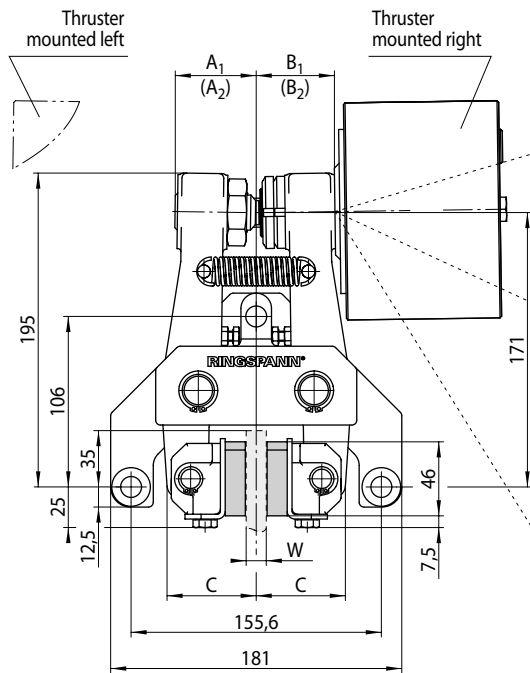
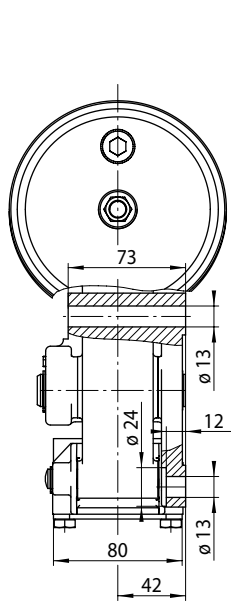

Thruster 065

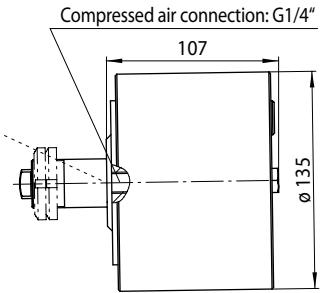

Thruster 085 and 095

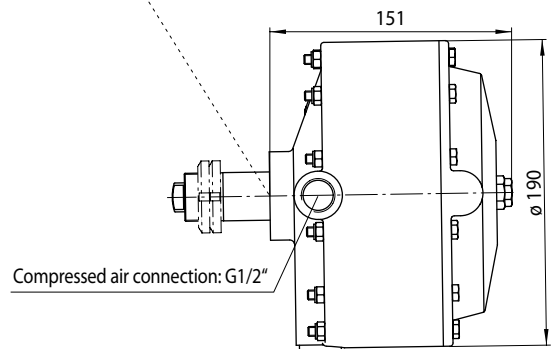

Thruster 105

Thickness of brake disc W mm	A ₁ mm	(A ₂) mm	B ₁ mm	(B ₂) mm	C mm
12,5	51	(69)	49	(66)	55
25	57	(76)	56	(73)	62

Values in brackets resulting with maximum friction block wear.

Brake Caliper DV 035 FPM

spring activated – pneumatically released

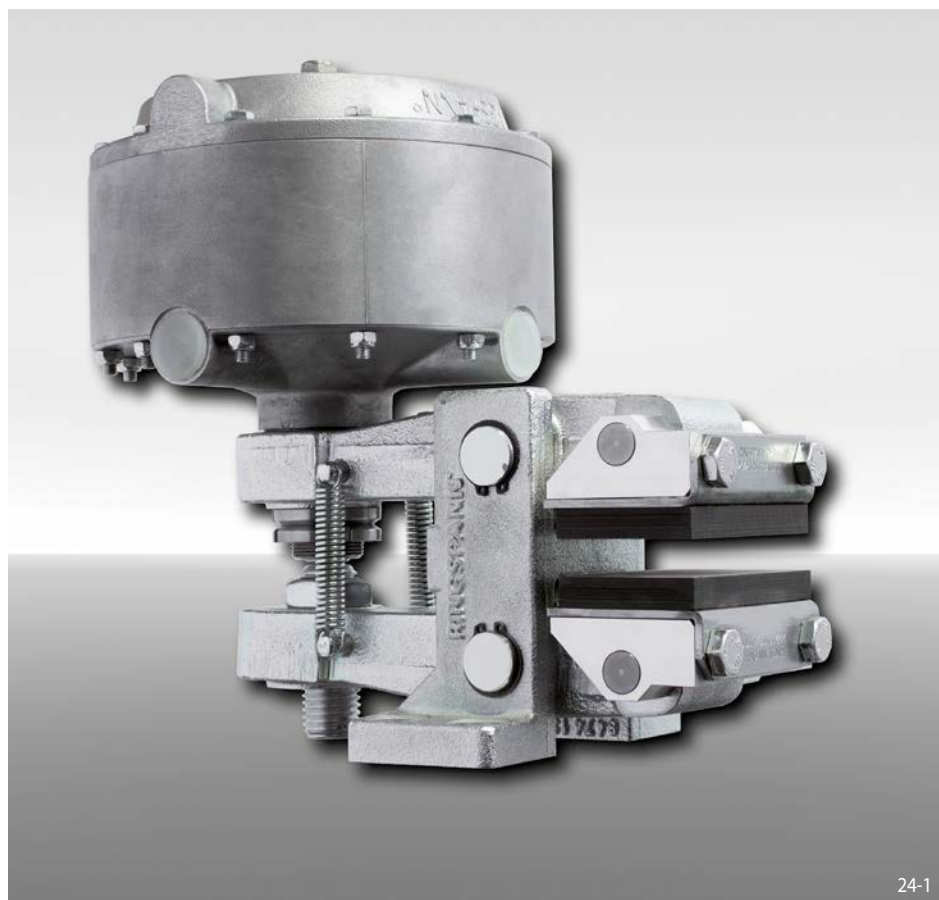

Features	Code
Brake Caliper	D
Mounting to the machine parallel to the brake disc	V
Frame size 035	035
Spring activated	F
Pneumatically released	P
Manual adjustment to accommodate friction block wear	M
Thrusters 025, 035, 045, 102, 111 or 122 are available	025 to 122
Thruster mounted right available	R
Thickness of brake disc 12,5 mm, 25 mm, 30 mm or 40 mm	12 to 40

Example for ordering

Brake Caliper DV 035 FPM, thruster 111, thruster mounted right, thickness of brake disc 12,5 mm:

Technical Data

DV 035 FPM - 111 R - 12

	Brake Caliper DV 035 FPM					
	with thruster 025	with thruster 035	with thruster 045	with thruster 102	with thruster 111	with thruster 122
Brake disc diameter	Braking torque	Braking torque	Braking torque	Braking torque	Braking torque	Braking torque
mm	Nm	Nm	Nm	Nm	Nm	Nm
300	430	640	900	820	1450	1850
355	530	790	1100	1000	1750	2250
430	670	990	1400	1300	2250	2850
520	840	1250	1750	1600	2800	3550
630	1050	1550	2150	2000	3450	4400
710	1200	1750	2450	2250	3950	5000
800	1350	2000	2800	2600	4500	5750
Clamping force	4600 N	6800 N	9600 N	8800 N	15300 N	19500 N
Air pressure	min. 5 bar max. 8 bar	min. 4,2 bar max. 8 bar	min. 5 bar max. 8 bar	min. 3 bar max. 8 bar	min. 5 bar max. 8 bar	min. 6,5 bar max. 8 bar
Air volume per activation	max. 120 cm ³	max. 185 cm ³	max. 185 cm ³	max. 540 cm ³	max. 540 cm ³	max. 540 cm ³
Weight	10,6 kg	13,0 kg	13,0 kg	14,2 kg	14,2 kg	14,2 kg

The braking torques shown in the table are based on a theoretical friction coefficient of 0,4.

Brake Caliper DV 035 FPM

spring activated – pneumatically released

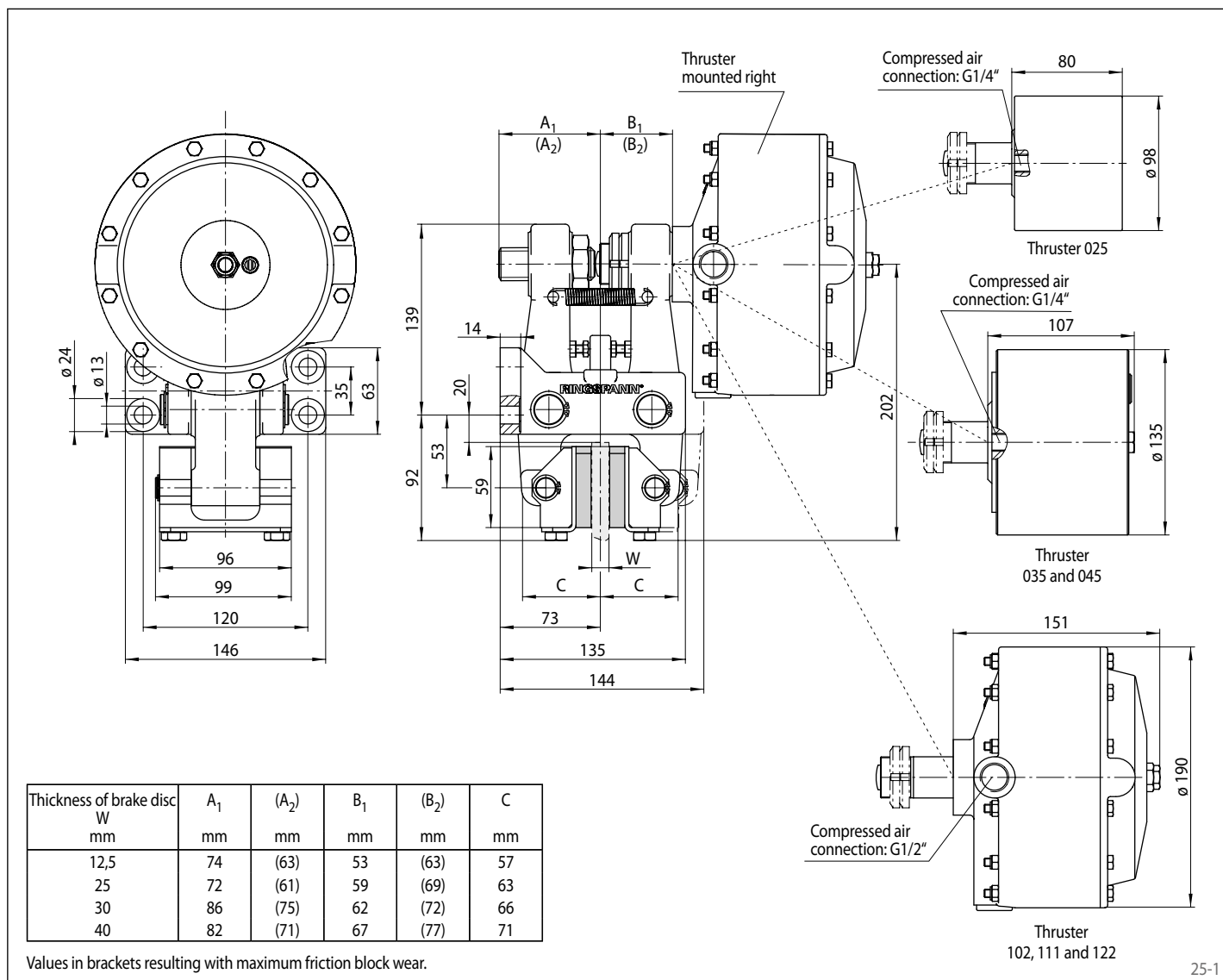

Brake Caliper DH 035 FPM

spring activated – pneumatically released

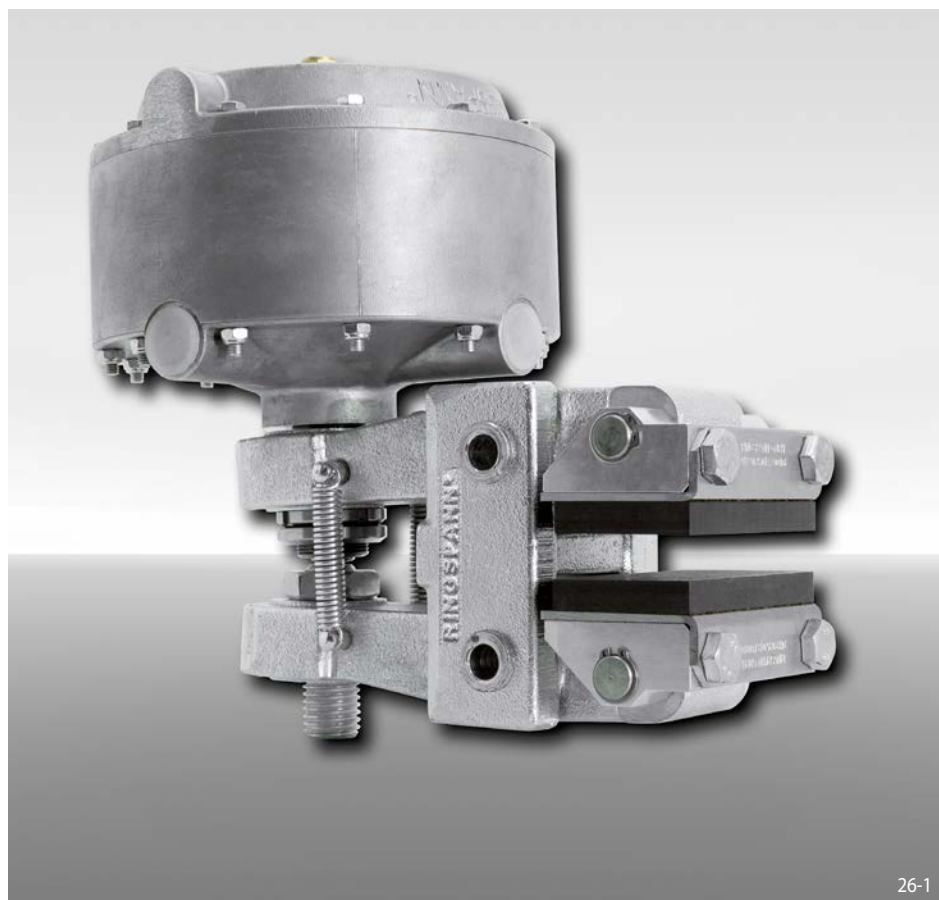

Features	Code
Brake Caliper	D
Mounting to the machine at right angles to the brake disc	H
Frame size 035	035
Spring activated	F
Pneumatically released	P
Manual adjustment to accommodate friction block wear	M
Thrusters 025, 035, 045, 102, 111 or 122 are available	025 to 122
Thruster mounted right or left available	R L
Thickness of brake disc 12,5 mm, 25 mm, 30 mm or 40 mm	12 to 40

Example for ordering

Brake Caliper DH 035 FPM, thruster 111, thruster mounted right, thickness of brake disc 12,5 mm:

Technical Data

DH 035 FPM - 111 R - 12

	Brake Caliper DH 035 FPM					
	with thruster 025	with thruster 035	with thruster 045	with thruster 102	with thruster 111	with thruster 122
Brake disc diameter	Braking torque	Braking torque	Braking torque	Braking torque	Braking torque	Braking torque
mm	Nm	Nm	Nm	Nm	Nm	Nm
300	430	640	900	820	1450	1850
355	530	790	1100	1000	1750	2250
430	670	990	1400	1300	2250	2850
520	840	1250	1750	1600	2800	3550
630	1050	1550	2150	2000	3450	4400
710	1200	1750	2450	2250	3950	5000
800	1350	2000	2800	2600	4500	5750
Clamping force	4600 N	6800 N	9600 N	8800 N	15300 N	19500 N
Air pressure	min. 5 bar max. 8 bar	min. 4,2 bar max. 8 bar	min. 5 bar max. 8 bar	min. 3 bar max. 8 bar	min. 5 bar max. 8 bar	min. 6,5 bar max. 8 bar
Air volume per activation	max. 120 cm ³	max. 185 cm ³	max. 185 cm ³	max. 540 cm ³	max. 540 cm ³	max. 540 cm ³
Weight	10,6 kg	13,0 kg	13,0 kg	14,2 kg	14,2 kg	14,2 kg

The braking torques shown in the table are based on a theoretical friction coefficient of 0,4.

Brake Caliper DH 035 FPM

spring activated – pneumatically released

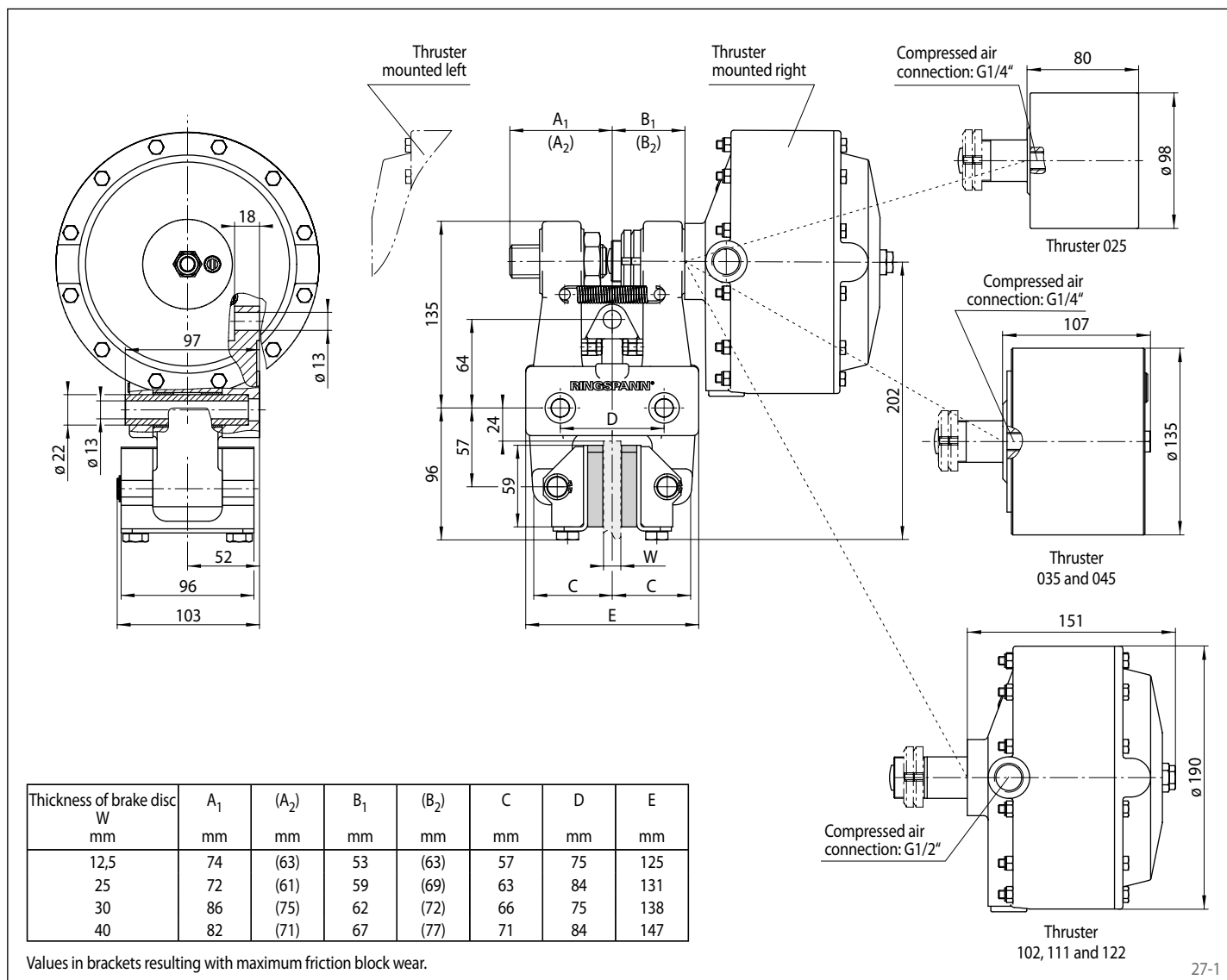

Brake Caliper DV 035 FPA

spring activated – pneumatically released

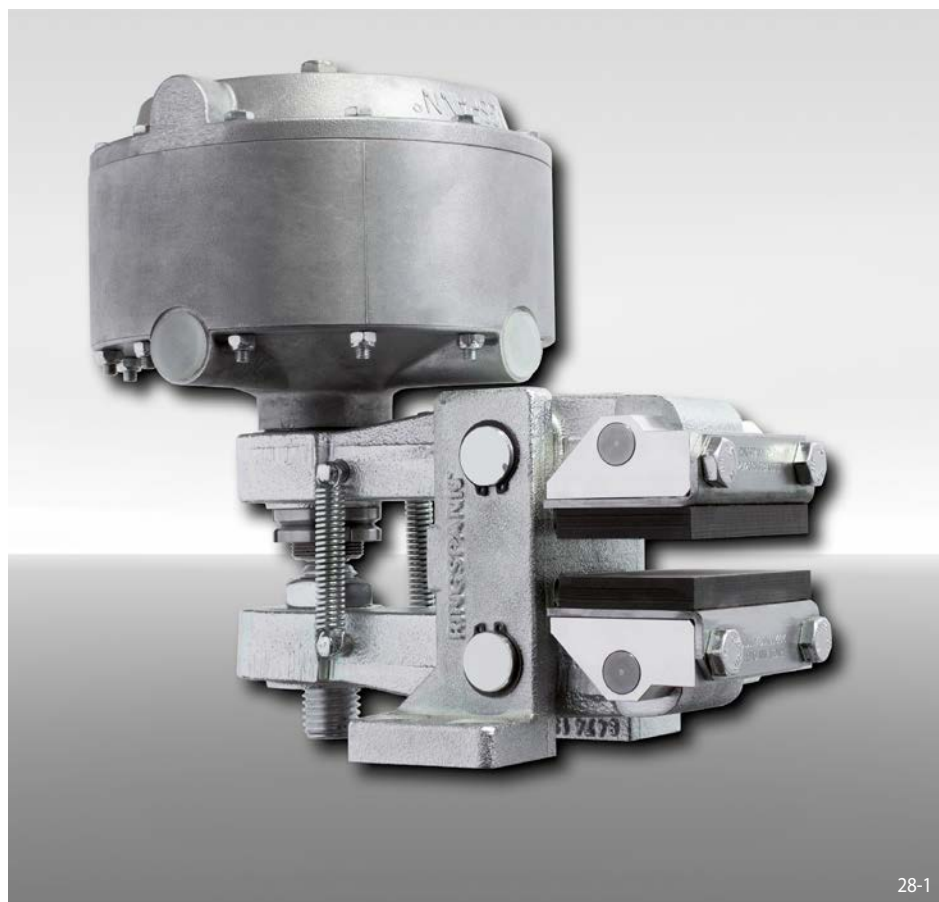

Features	Code
Brake Caliper	D
Mounting to the machine parallel to the brake disc	V
Frame size 035	035
Spring activated	F
Pneumatically released	P
Automatic adjustment to accommodate friction block wear	A
Thrusters 065, 085, 095, 115 or 125 are available	065 to 125
Thruster mounted right available	R
Thickness of brake disc 12,5 mm, 25 mm, 30 mm or 40 mm	12 to 40

Example for ordering

Brake Caliper DV 035 FPA, thruster 095, thruster mounted right, thickness of brake disc 12,5 mm:

DV 035 FPA - 095 R - 12

Technical Data

	Brake Caliper DV 035 FPA				
	with thruster 065	with thruster 085	with thruster 095	with thruster 115	with thruster 125
Brake disc diameter	Braking torque	Braking torque	Braking torque	Braking torque	Braking torque
mm	Nm	Nm	Nm	Nm	Nm
300	400	230	830	1350	1750
355	500	290	1050	1700	2150
430	630	360	1300	2100	2700
520	780	450	1600	2650	3350
630	970	560	2000	3250	4150
710	1100	640	2300	3750	4750
800	1250	730	2600	4250	5450
Clamping force	4300 N	2500 N	8900 N	14500 N	18500 N
Air pressure	min. 5 bar max. 8 bar	min. 1,7 bar max. 8 bar	min. 5 bar max. 8 bar	min. 5 bar max. 8 bar	min. 6,5 bar max. 8 bar
Air volume per activation	max. 72 cm ³	max. 140 cm ³	max. 140 cm ³	max. 460 cm ³	max. 460 cm ³
Weight	10,9 kg	13,3 kg	13,3 kg	14,9 kg	14,9 kg

The braking torques shown in the table are based on a theoretical friction coefficient of 0,4.

Brake Caliper DV 035 FPA

spring activated – pneumatically released

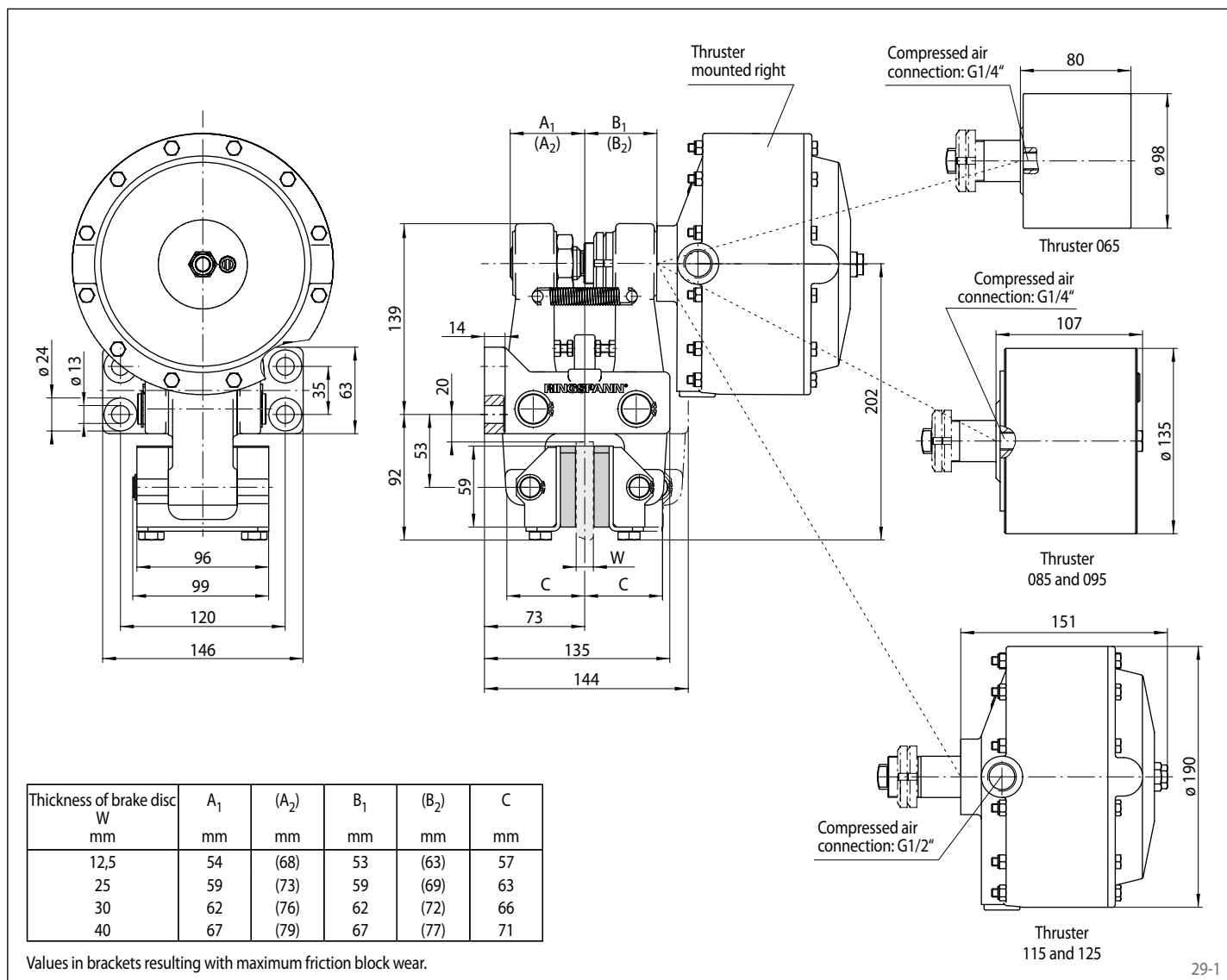

Brake Caliper DH 035 FPA

spring activated – pneumatically released



Features	Code
Brake Caliper	D
Mounting to the machine at right angles to the brake disc	H
Frame size 035	035
Spring activated	F
Pneumatically released	P
Automatic adjustment to accommodate friction block wear	A
Thrusters 065, 085, 095, 115 or 125 are available	065 to 125
Thruster mounted right or left available	R L
Thickness of brake disc 12,5 mm, 25 mm, 30 mm or 40 mm	12 to 40

Example for ordering

Brake Caliper DH 035 FPA, thruster 095, thruster mounted right, thickness of brake disc 12,5 mm:

Technical Data

DH 035 FPA - 095 R - 12

	Brake Caliper DH 035 FPA				
	with thruster 065	with thruster 085	with thruster 095	with thruster 115	with thruster 125
Brake disc diameter	Braking torque	Braking torque	Braking torque	Braking torque	Braking torque
mm	Nm	Nm	Nm	Nm	Nm
300	400	230	830	1350	1750
355	500	290	1050	1700	2150
430	630	360	1300	2100	2700
520	780	450	1600	2650	3350
630	970	560	2000	3250	4150
710	1100	640	2300	3750	4750
800	1250	730	2600	4250	5450
Clamping force	4300 N	2500 N	8900 N	14500 N	18500 N
Air pressure	min. 5 bar max. 8 bar	min. 1,7 bar max. 8 bar	min. 5 bar max. 8 bar	min. 5 bar max. 8 bar	min. 6,5 bar max. 8 bar
Air volume per activation	max. 72 cm ³	max. 140 cm ³	max. 140 cm ³	max. 460 cm ³	max. 460 cm ³
Weight	10,9 kg	13,3 kg	13,3 kg	14,9 kg	14,9 kg

The braking torques shown in the table are based on a theoretical friction coefficient of 0,4.

Brake Caliper DH 035 FPA

spring activated – pneumatically released

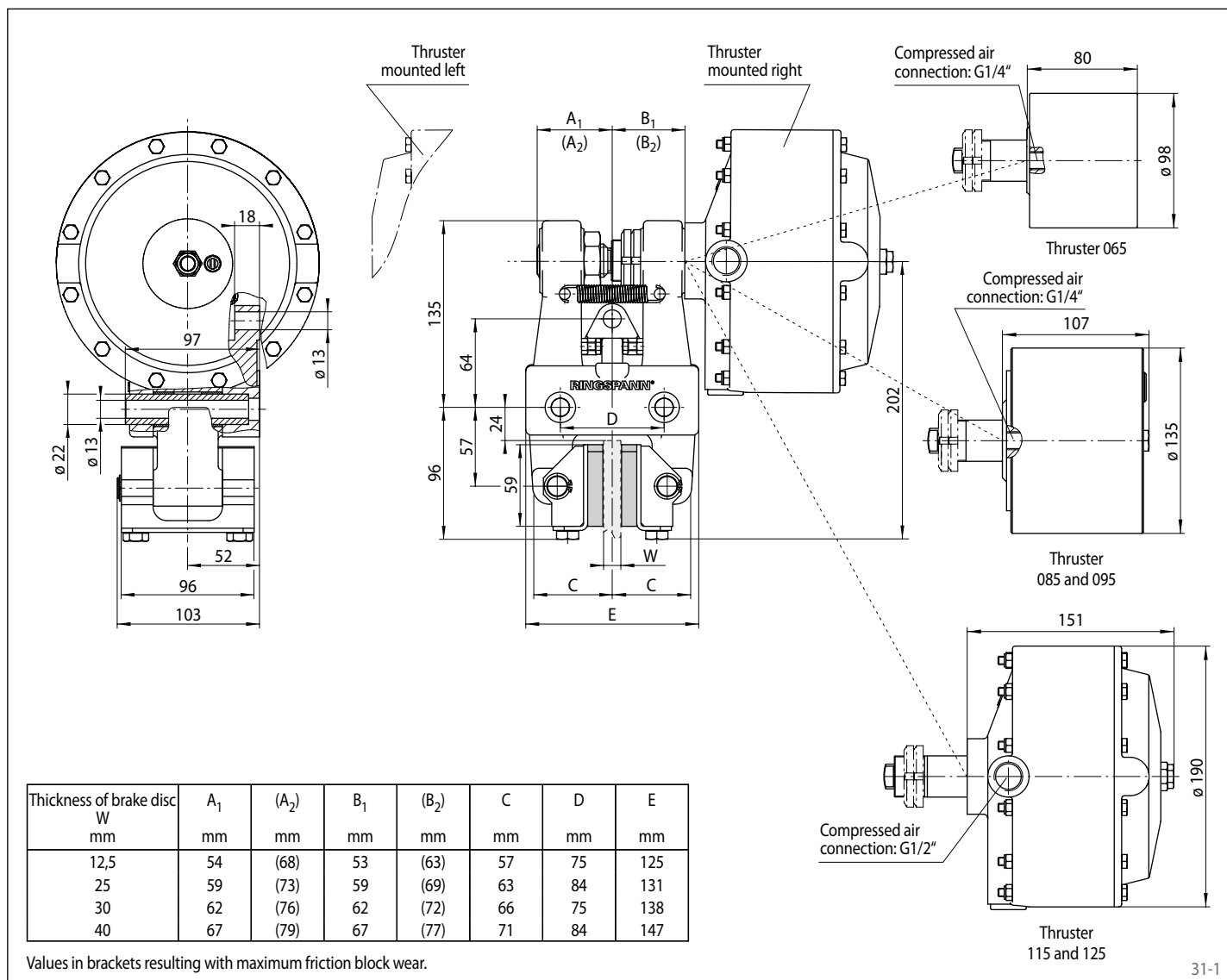

Brake Caliper DU 060 FPM

spring activated – pneumatically released

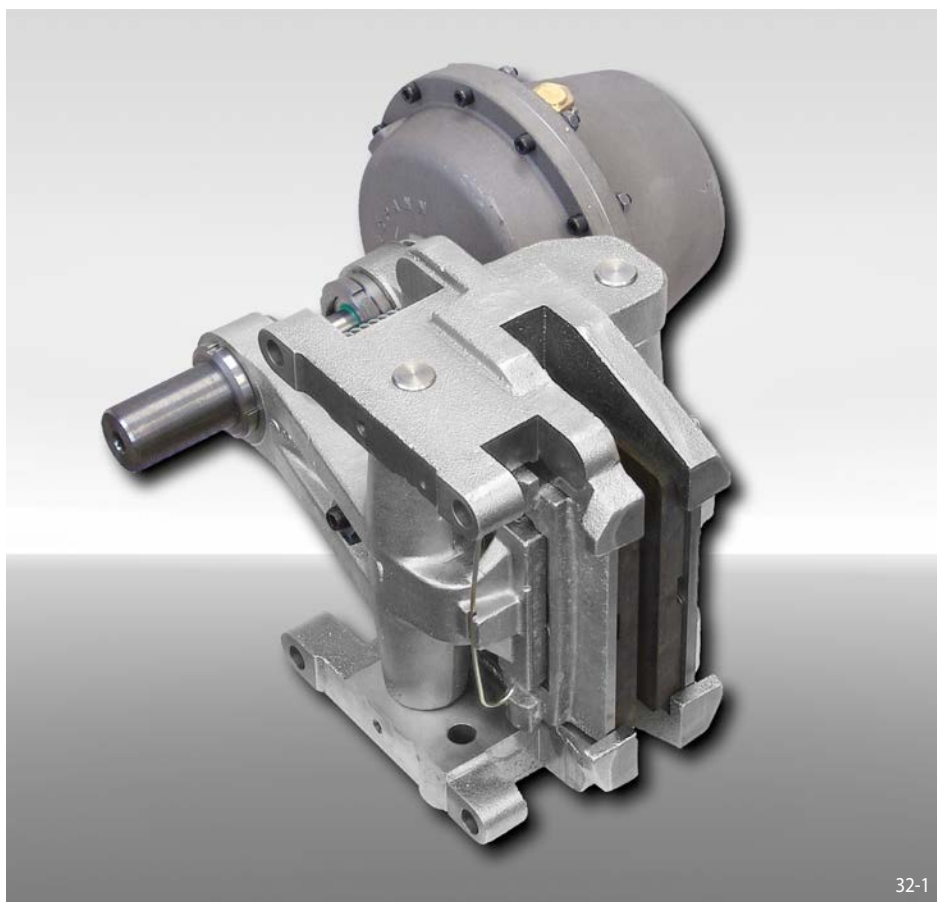

Features	Code
Brake Caliper	D
Mounting to the machine, can be made either parallel or at the right angles to the brake disc	U
Frame size 060	060
Spring activated	F
Pneumatically released	P
Manual adjustment to accommodate friction block wear	M
Thrusters 111, 122, 130, 135, 140, 150, 155 or 160 are available	111 to 160
Thruster mounted right or left available	R L
Thickness of brake disc 25 mm or 40 mm	25 40

Example for ordering

Brake Caliper DU 060 FPM, thruster 130, thruster mounted right, thickness of brake disc 25 mm:

32-1

DU 060 FPM - 130 R - 25

Technical Data

	Brake Caliper DU 060 FPM							
	with thruster 111	with thruster 122	with thruster 130	with thruster 135	with thruster 140	with thruster 150	with thruster 155	with thruster 160
Brake disc diameter	Braking torque	Braking torque	Braking torque	Braking torque	Braking torque	Braking torque	Braking torque	Braking torque
mm	Nm	Nm	Nm	Nm	Nm	Nm	Nm	Nm
630	4900	6300	2700	5400	7800	7300	10300	13000
710	5600	7300	3100	6200	9000	8500	12000	15500
800	6500	8400	3600	7200	10300	9700	14000	17500
900	7400	9700	4100	8300	11900	11200	16000	20500
1000	8400	10900	4700	9300	13500	12500	18000	23000
1250	10700	14000	6000	12000	17000	16000	23000	29500
1600	14000	18500	7800	16000	22500	21000	30000	38500
Clamping force	24000 N	31000 N	13200 N	26500 N	38000 N	36000 N	51000 N	65000 N
Air pressure	min. 5 bar max. 8 bar	min. 6,5 bar max. 8 bar	min. 2,8 bar max. 8,5 bar	min. 5,5 bar max. 8,5 bar	min. 8,5 bar max. 10 bar	min. 4,5 bar max. 8,5 bar	min. 5,5 bar max. 8,5 bar	min. 7,6 bar max. 8,5 bar
Air volume per activation	max. 80 cm ³	max. 80 cm ³	max. 200 cm ³	max. 200 cm ³	max. 200 cm ³	max. 400 cm ³	max. 400 cm ³	max. 400 cm ³
Weight	60 kg	60 kg	62 kg	62 kg	62 kg	70 kg	70 kg	70 kg

The braking torques shown in the table are based on a theoretical friction coefficient of 0,4.

Brake Caliper DU 060 FPM

spring activated – pneumatically released

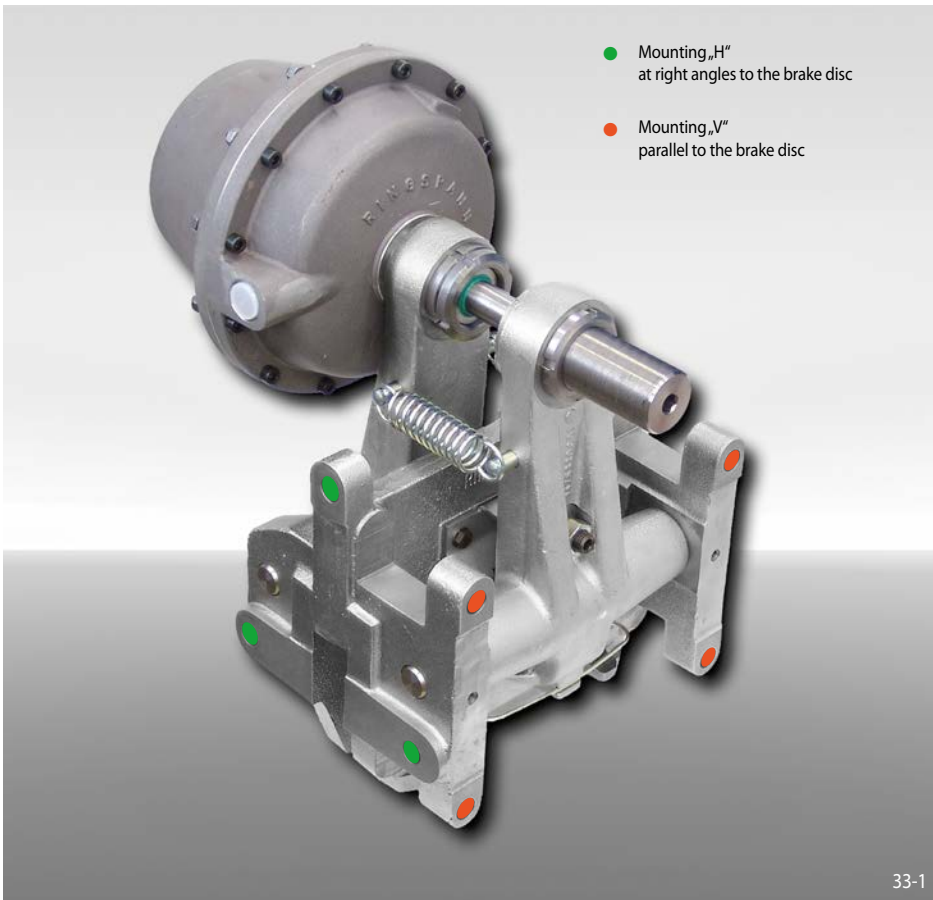

- Mounting „H“ at right angles to the brake disc
- Mounting „V“ parallel to the brake disc

Frame Design

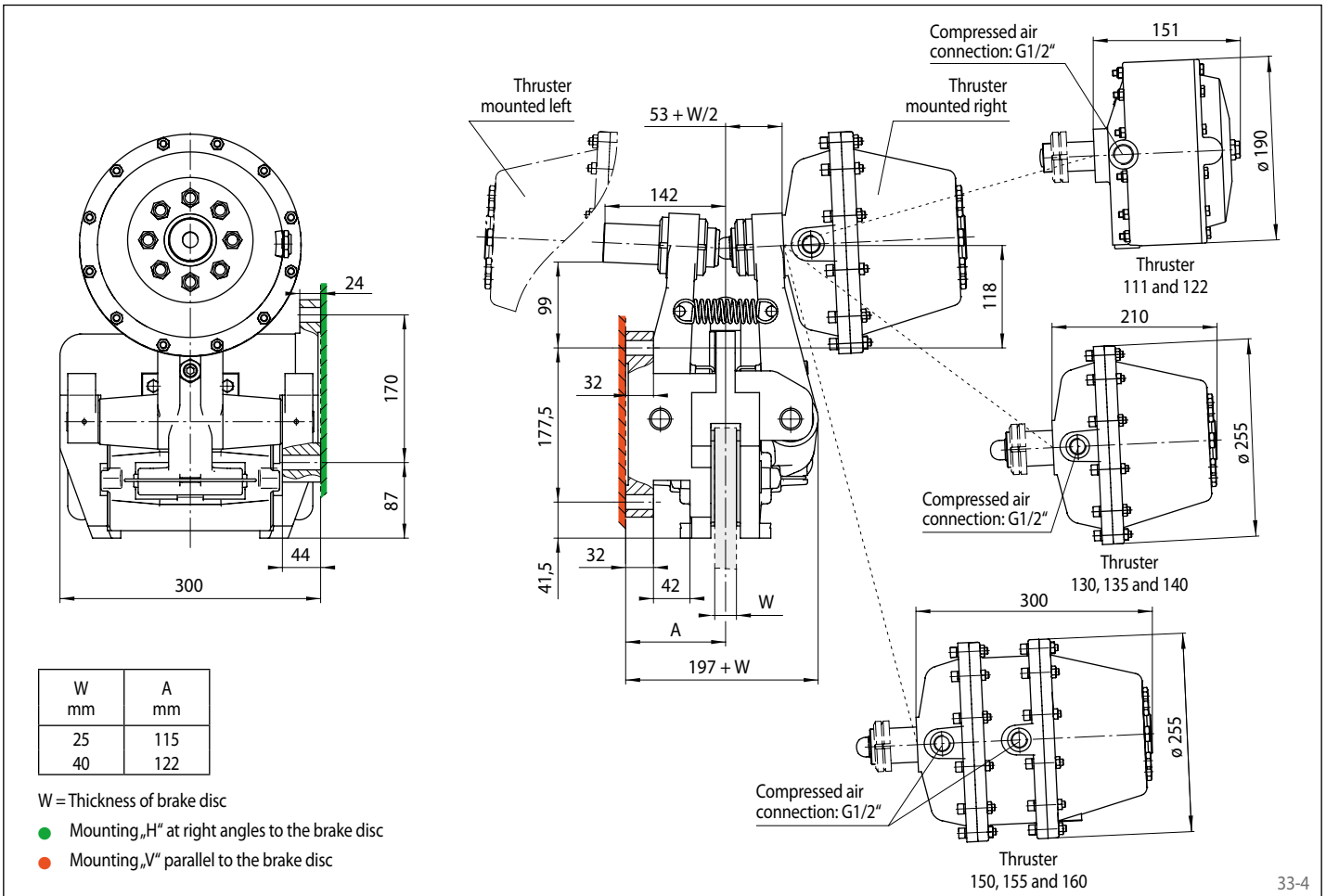
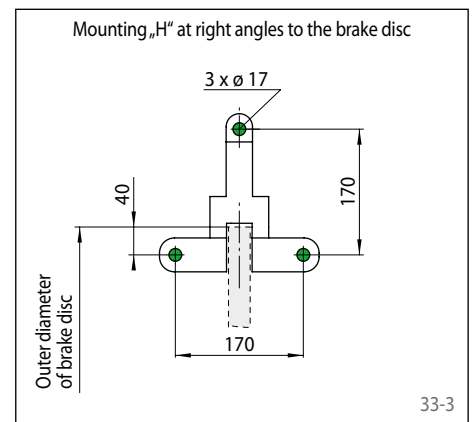
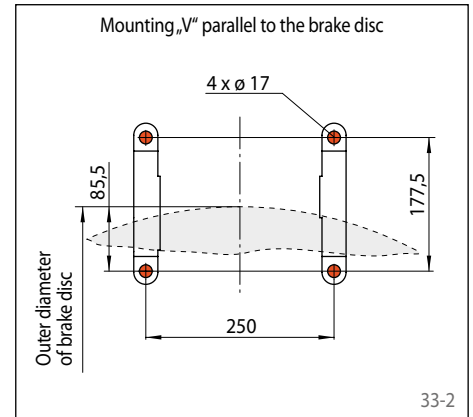

W mm	A mm
25	115
40	122

W = Thickness of brake disc

- Mounting „H“ at right angles to the brake disc
- Mounting „V“ parallel to the brake disc

Brake Caliper DV 020 FHM

spring activated – hydraulically released



Features

Features	Code
Brake Caliper	D
Mounting to the machine parallel to the brake disc	V
Frame size 020	020
Spring activated	F
Hydraulically released	H
Manual adjustment to accommodate friction block wear	M
Thruster 210	210
Thruster mounted right or left available	R L
Thickness of brake disc 12,5 mm	12

Example for ordering

Brake Caliper DV 020 FHM, thruster 210, thruster mounted right, thickness of brake disc 12,5 mm:

DV 020 FHM - 210 R - 12

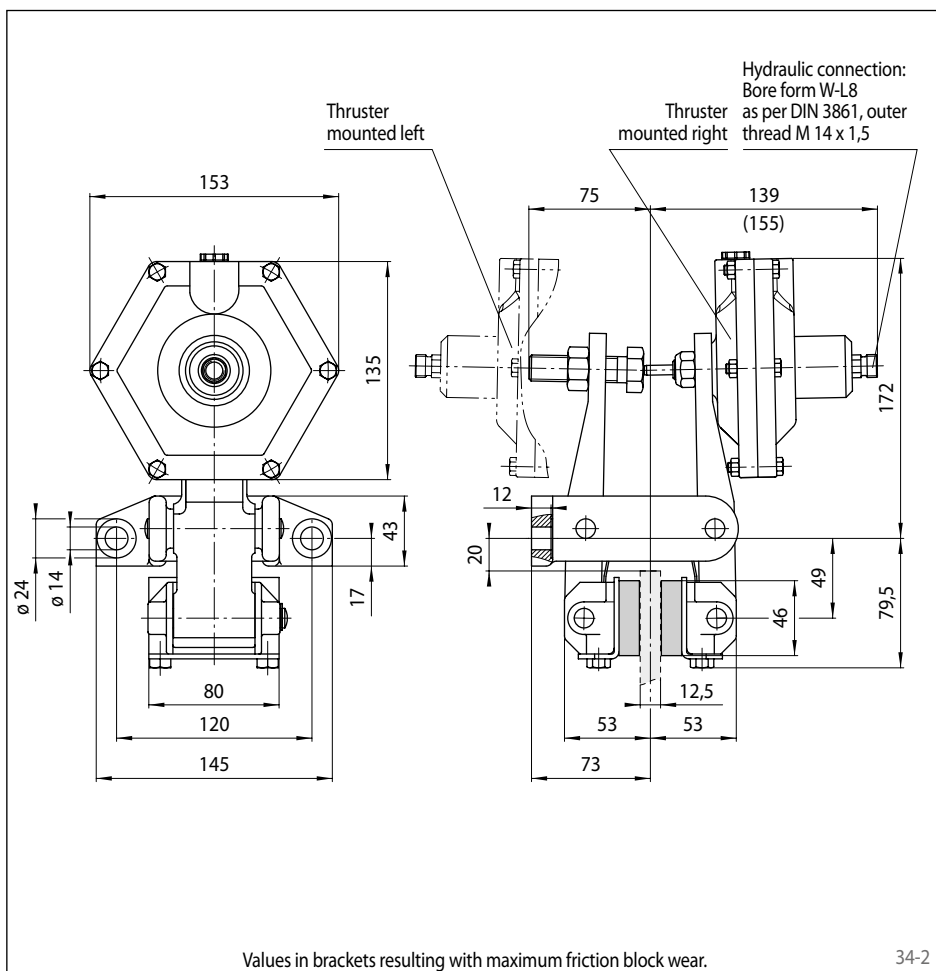

Technical Data

Brake Caliper DV 020 FHM with thruster 210	
Brake disc diameter	Braking torque
mm	Nm
200	200
250	270
300	340
355	420
430	520
520	650
Clamping force	3500 N
Oil pressure	min. 65 bar max. 100 bar
Oil volume	max. 2,5 cm ³
Weight	5,4 kg

The braking torques shown in the diagram are based on a theoretical friction coefficient of 0,4.

Brake Caliper DH 020 FHM

spring activated – hydraulically released



35-1

Features	Code
Brake Caliper	D
Mounting to the machine at right angles to the brake disc	H
Frame size 020	020
Spring activated	F
Hydraulically released	H
Manual adjustment to accommodate friction block wear	M
Thruster 210	210
Position of the thruster to the right or left can be defined by turning the brake around during installation	U
Thickness of brake disc 12,5 mm	12

Example for ordering

Brake Caliper DH 020 FHM, thruster 210, position of the thruster can be to the right or left, thickness of brake disc 12,5 mm:

DH 020 FHM - 210 U - 12

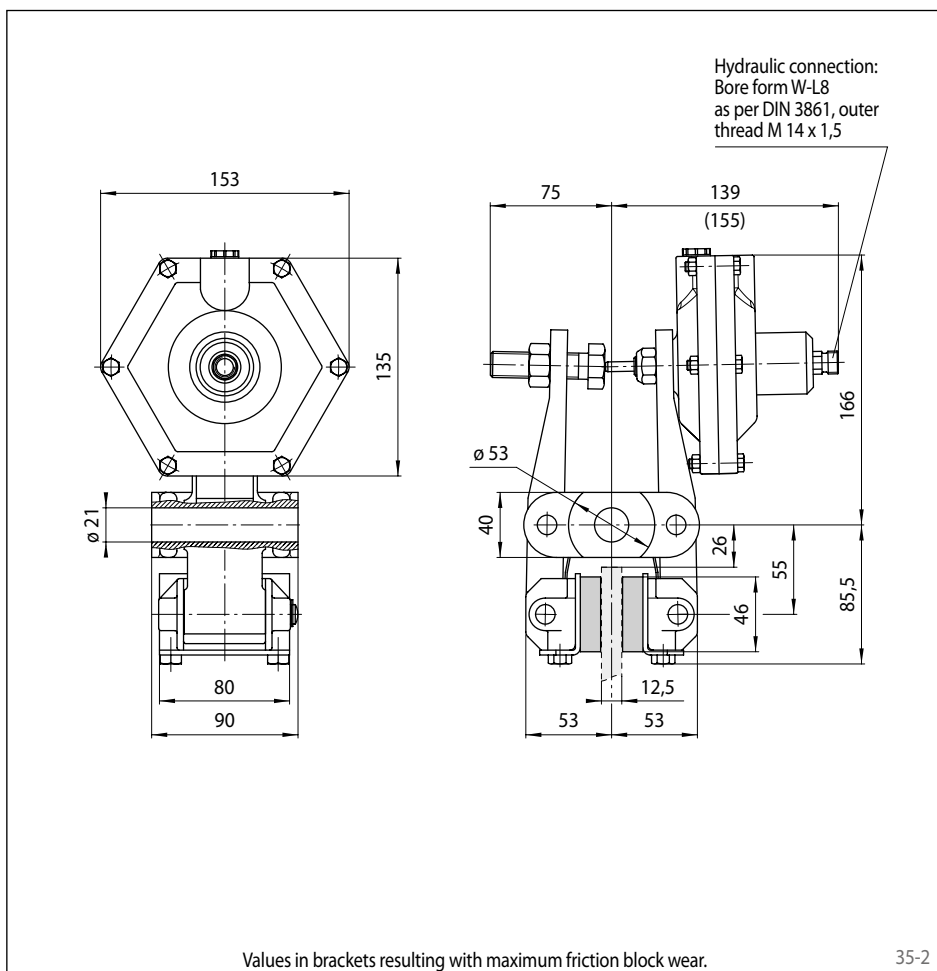

Technical Data

Brake Caliper DH 020 FHM with thruster 210	
Brake disc diameter	Braking torque
mm	Nm
200	200
250	270
300	340
355	420
430	520
520	650
Clamping force	3 500 N
Oil pressure	min. 65 bar max. 100 bar
Oil volume	max. 2,5 cm ³
Weight	5,4 kg

The braking torques shown in the diagram are based on a theoretical friction coefficient of 0,4.

Brake Caliper DV 030 FHM

spring activated – hydraulically released

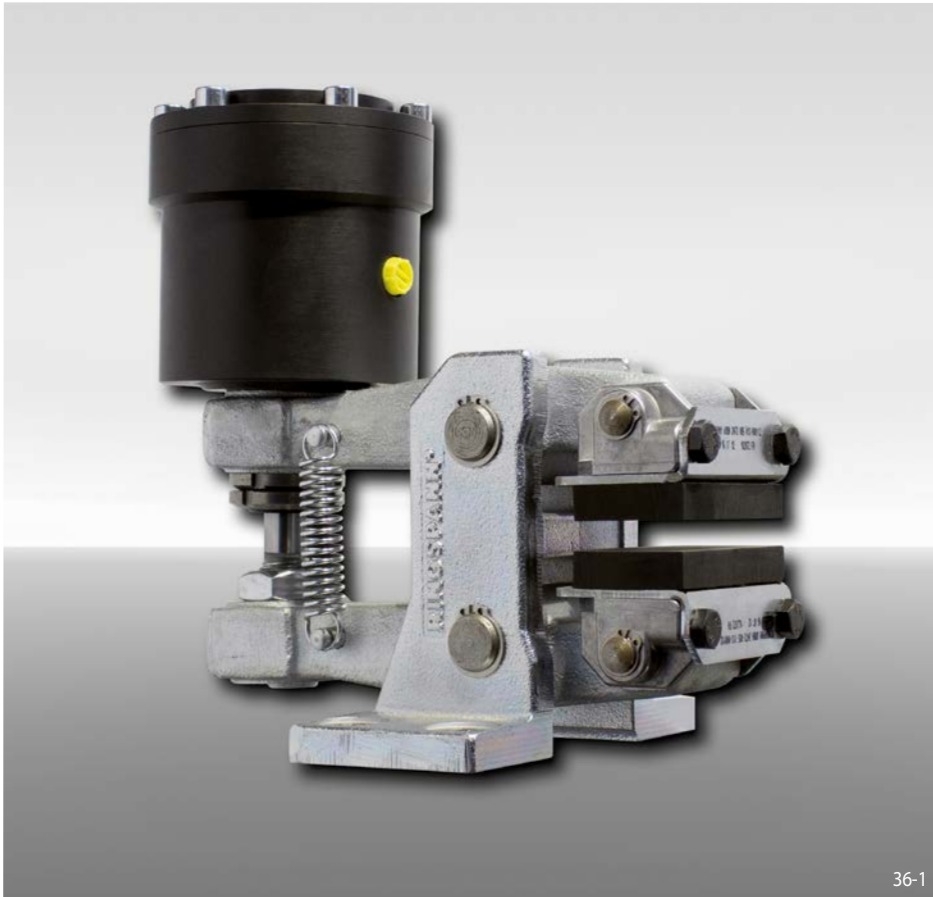

Features

Features	Code
Brake Caliper	D
Mounting to the machine parallel to the brake disc	V
Frame size 030	030
Spring activated	F
Hydraulically released	H
Manual adjustment to accommodate friction block wear	M
Thruster 250	250
Thruster mounted right or left available	R L
Thickness of brake disc 12,5 mm or 25 mm	12 25

Example for ordering

Brake Caliper DV 030 FHM, thruster 250, thruster mounted right, thickness of brake disc 12,5 mm:

DV 030 FHM - 250 R - 12

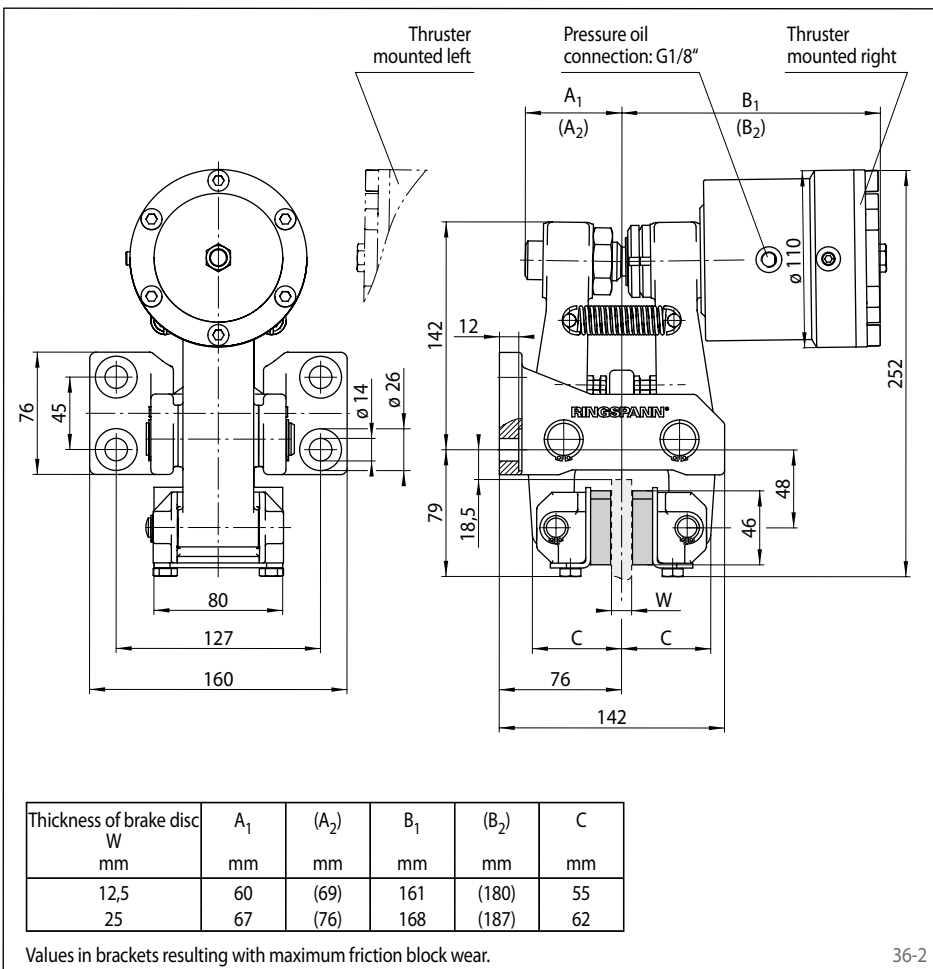

Technical Data

Brake Caliper DV 030 FHM with thruster 250	
Brake disc diameter mm	Braking torque Nm
200	620
250	840
300	1100
355	1300
430	1600
520	2000
Clamping force	11000 N
Oil pressure	min. 40 bar max. 120 bar
Oil volume	max. 6 cm ³
Weight	14,5 kg

The braking torques shown in the diagram are based on a theoretical friction coefficient of 0,4.

Brake Caliper DH 030 FHM

spring activated – hydraulically released



Features	Code
Brake Caliper	D
Mounting to the machine at right angles to the brake disc	H
Frame size 030	030
Spring activated	F
Hydraulically released	H
Manual adjustment to accommodate friction block wear	M
Thruster 250	250
Thruster mounted right or left available	R L
Thickness of brake disc 12,5 mm or 25 mm	12 25

Example for ordering

Brake Caliper DH 030 FHM, thruster 250, thruster mounted right, thickness of brake disc 12,5 mm:

DH 030 FHM - 250 R - 12

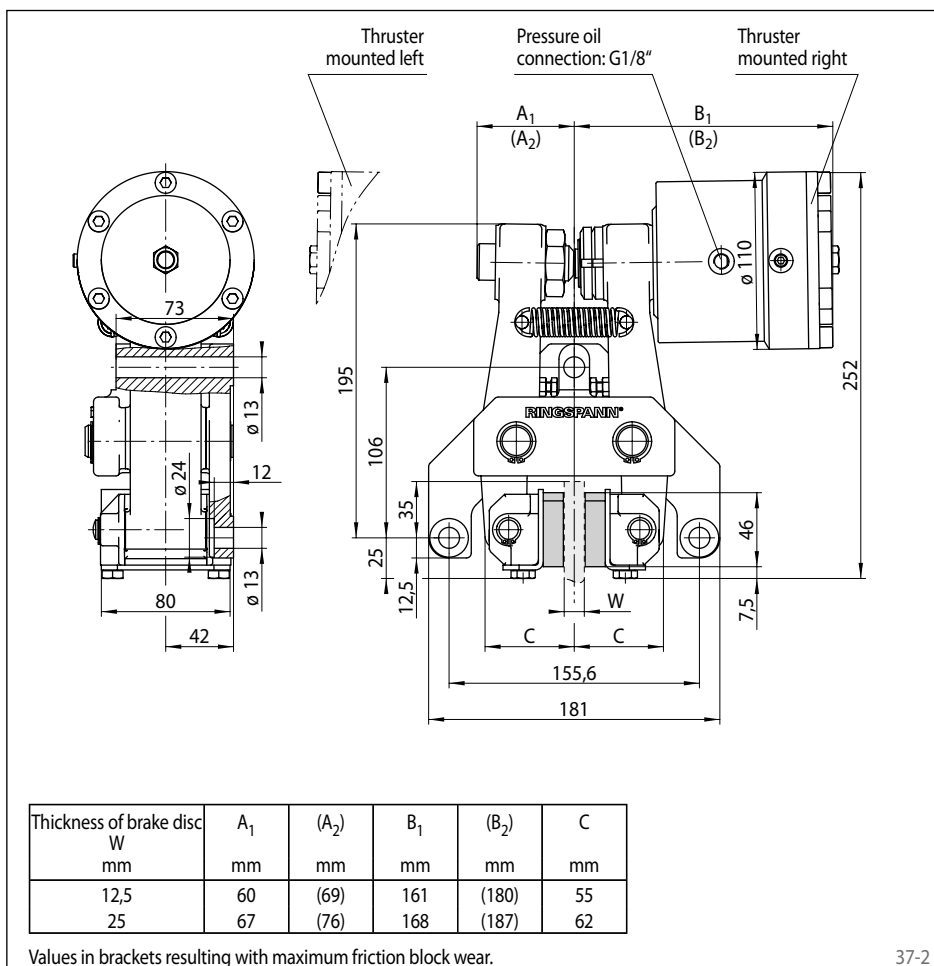

Technical Data

Brake Caliper DH 030 FHM with thruster 250	
Brake disc diameter mm	Braking torque Nm
200	620
250	840
300	1 100
355	1 300
430	1 600
520	2 000
Clamping force	11 000 N
Oil pressure	min. 40 bar max. 120 bar
Oil volume	max. 6 cm ³
Weight	14,5 kg

The braking torques shown in the diagram are based on a theoretical friction coefficient of 0,4.

37-1

37-2

Brake Caliper DV 030 FHA

spring activated – hydraulically released

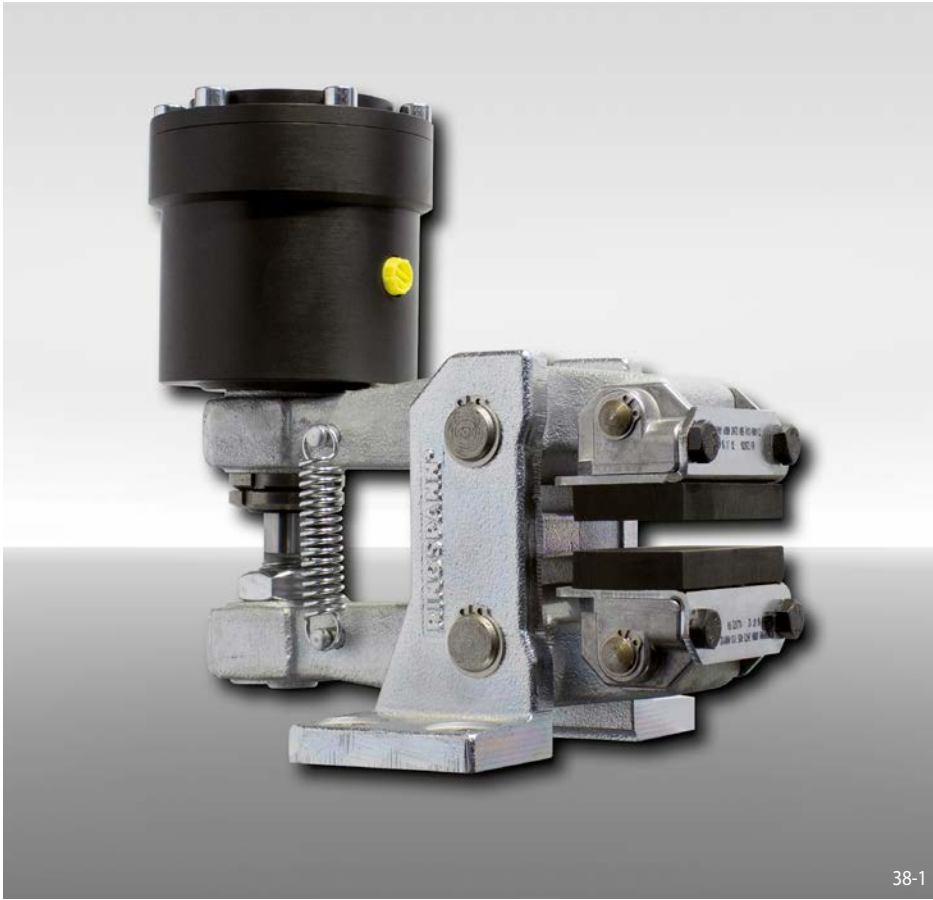

Features

Features	Code
Brake Caliper	D
Mounting to the machine parallel to the brake disc	V
Frame size 030	030
Spring activated	F
Hydraulically released	H
Automatic adjustment to accommodate friction block wear	A
Thruster 240	240
Thruster mounted right or left available	R L
Thickness of brake disc 12,5 mm or 25 mm	12 25

Example for ordering

Brake Caliper DV 030 FHA, thruster 240, thruster mounted right, thickness of brake disc 12,5 mm:

DV 030 FHA - 240 R - 12

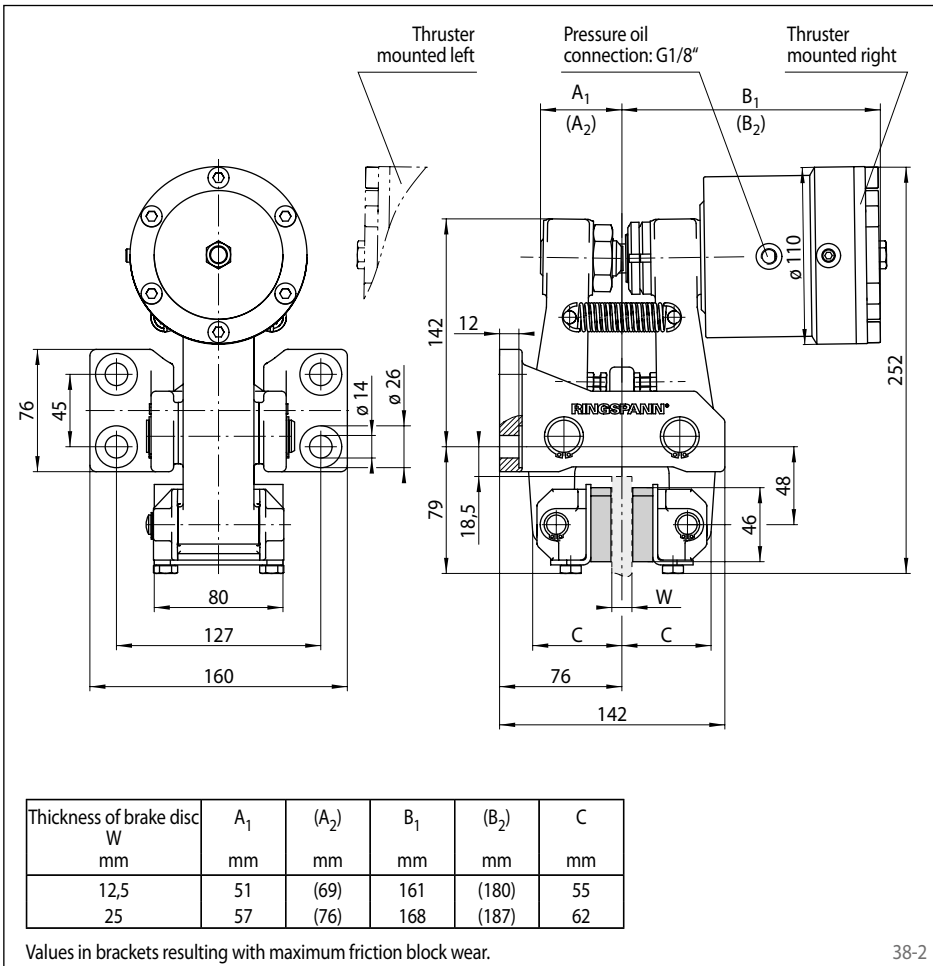

Technical Data

Brake Caliper DV 030 FHA with thruster 240	
Brake disc diameter mm	Braking torque Nm
200	620
250	840
300	1100
355	1300
430	1600
520	2000
Clamping force	11000 N
Oil pressure	min. 40 bar max. 120 bar
Oil volume	max. 6 cm ³
Weight	14,2 kg

The braking torques shown in the diagram are based on a theoretical friction coefficient of 0,4.

38-1

38-2

Brake Caliper DH 030 FHA

spring activated – hydraulically released



Features

Features	Code
Brake Caliper	D
Mounting to the machine at right angles to the brake disc	H
Frame size 030	030
Spring activated	F
Hydraulically released	H
Automatic adjustment to accommodate friction block wear	A
Thruster 240	240
Thruster mounted right or left available	R L
Thickness of brake disc 12,5 mm or 25 mm	12 25

Example for ordering

Brake Caliper DH 030 FHA, thruster 240, thruster mounted right, thickness of brake disc 12,5 mm:

DH 030 FHA - 240 R - 12

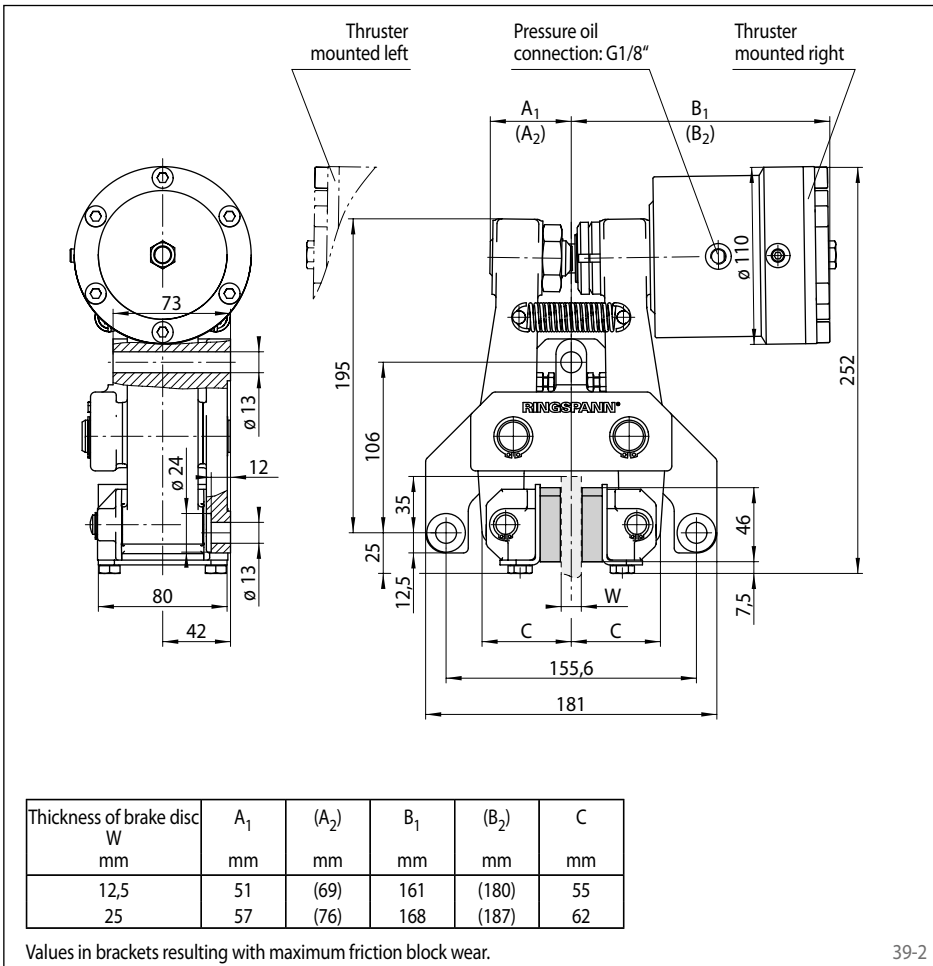

Technical Data

Brake Caliper DH 030 FHA with thruster 240	
Brake disc diameter mm	Braking torque Nm
200	620
250	840
300	1100
355	1300
430	1600
520	2000
Clamping force	11000 N
Oil pressure	min. 40 bar max. 120 bar
Oil volume	max. 6 cm ³
Weight	13,8 kg

The braking torques shown in the diagram are based on a theoretical friction coefficient of 0,4.

39-1

39-2

Brake Caliper DV 035 FHM

spring activated – hydraulically released



Features

Features	Code
Brake Caliper	D
Mounting to the machine parallel to the brake disc	V
Frame size 035	035
Spring activated	F
Hydraulically released	H
Manual adjustment to accommodate friction block wear	M
Thruster 270	270
Thruster mounted right or left available	R L
Thickness of brake disc 12,5 mm or 25 mm	12 25

Example for ordering

Brake Caliper DV 035 FHM, thruster 270, thruster mounted right, thickness of brake disc 12,5 mm:

DV 035 FHM - 270 R - 12

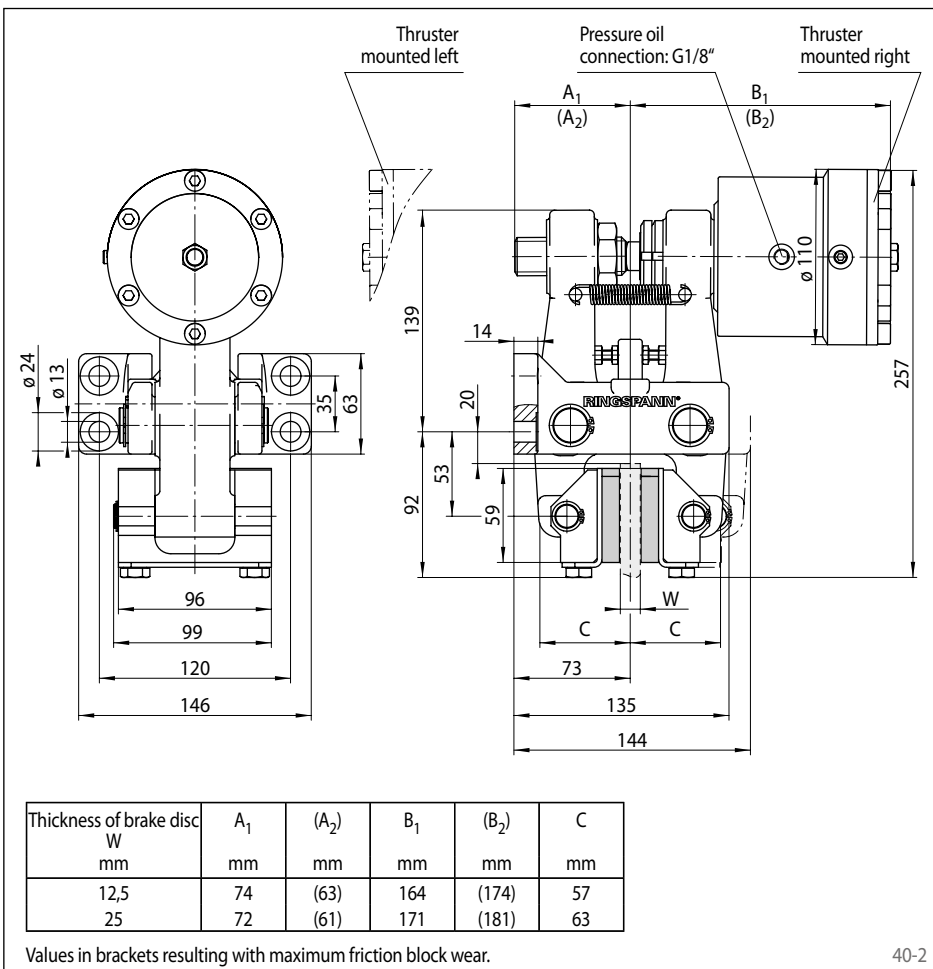

Technical Data

Brake Caliper DV 035 FHM with thruster 270	
Brake disc diameter mm	Braking torque Nm
300	1500
355	1850
430	2350
520	3000
630	3600
710	4100
800	4700
Clamping force	16000 N
Oil pressure	min. 55 bar max. 120 bar
Oil volume	max. 6 cm ³
Weight	13,7 kg

The braking torques shown in the diagram are based on a theoretical friction coefficient of 0,4.

Brake Caliper DH 035 FHM

spring activated – hydraulically released



Features

Features	Code
Brake Caliper	D
Mounting to the machine at right angles to the brake disc	H
Frame size 035	035
Spring activated	F
Hydraulically released	H
Manual adjustment to accommodate friction block wear	M
Thruster 270	270
Thruster mounted right or left available	R L
Thickness of brake disc 12,5 mm or 25 mm	12 25

Example for ordering

Brake Caliper DH 035 FHM, thruster 270, thruster mounted right, thickness of brake disc 12,5 mm:

DH 035 FHM - 270 R - 12

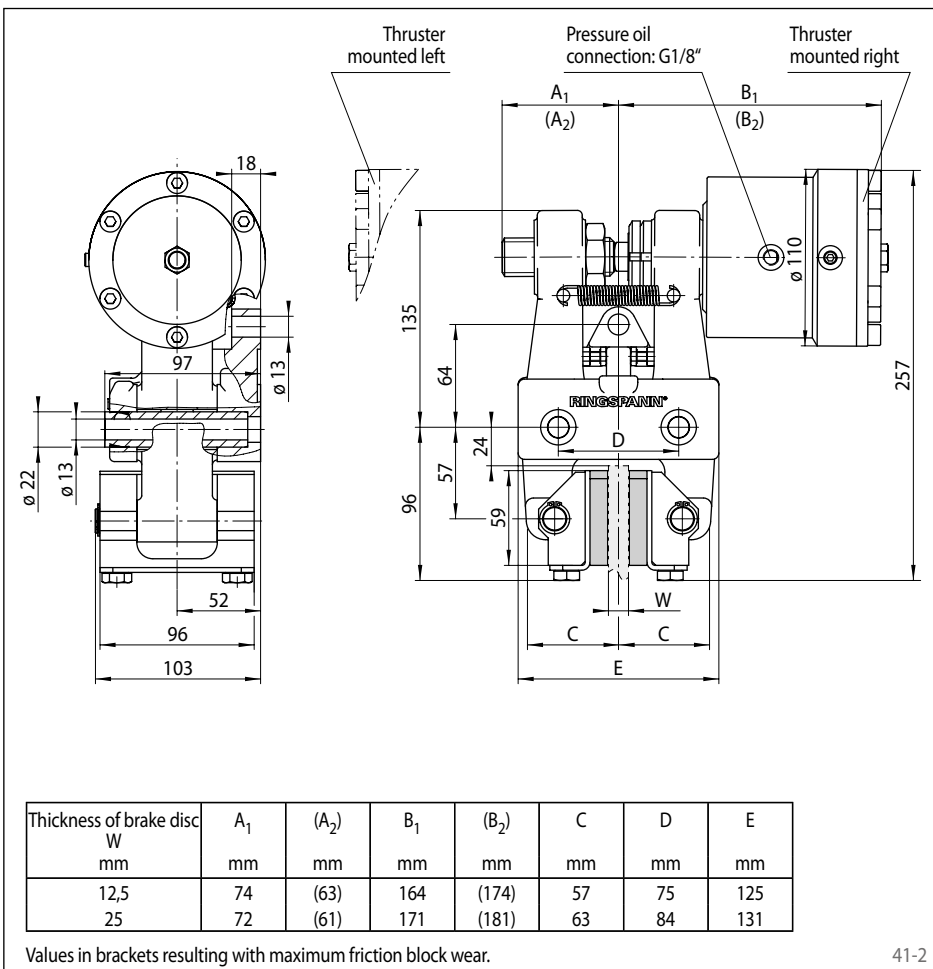

Technical Data

Brake Caliper DH 035 FHM with thruster 270	
Brake disc diameter mm	Braking torque Nm
300	1500
355	1850
430	2350
520	3000
630	3600
710	4100
800	4700
Clamping force	16000 N
Oil pressure	min. 55 bar max. 120 bar
Oil volume	max. 6 cm ³
Weight	13,9 kg

The braking torques shown in the diagram are based on a theoretical friction coefficient of 0,4.

41-1

41-2

Brake Caliper DV 035 FHA

spring activated – hydraulically released



Features	Code
Brake Caliper	D
Mounting to the machine parallel to the brake disc	V
Frame size 035	035
Spring activated	F
Hydraulically released	H
Automatic adjustment to accommodate friction block wear	A
Thruster 260	260
Thruster mounted right or left available	R L
Thickness of brake disc 12,5 mm or 25 mm	12 25

Example for ordering

Brake Caliper DV 035 FHA, thruster 260, thruster mounted right, thickness of brake disc 12,5 mm:

DV 035 FHA - 260 R - 12

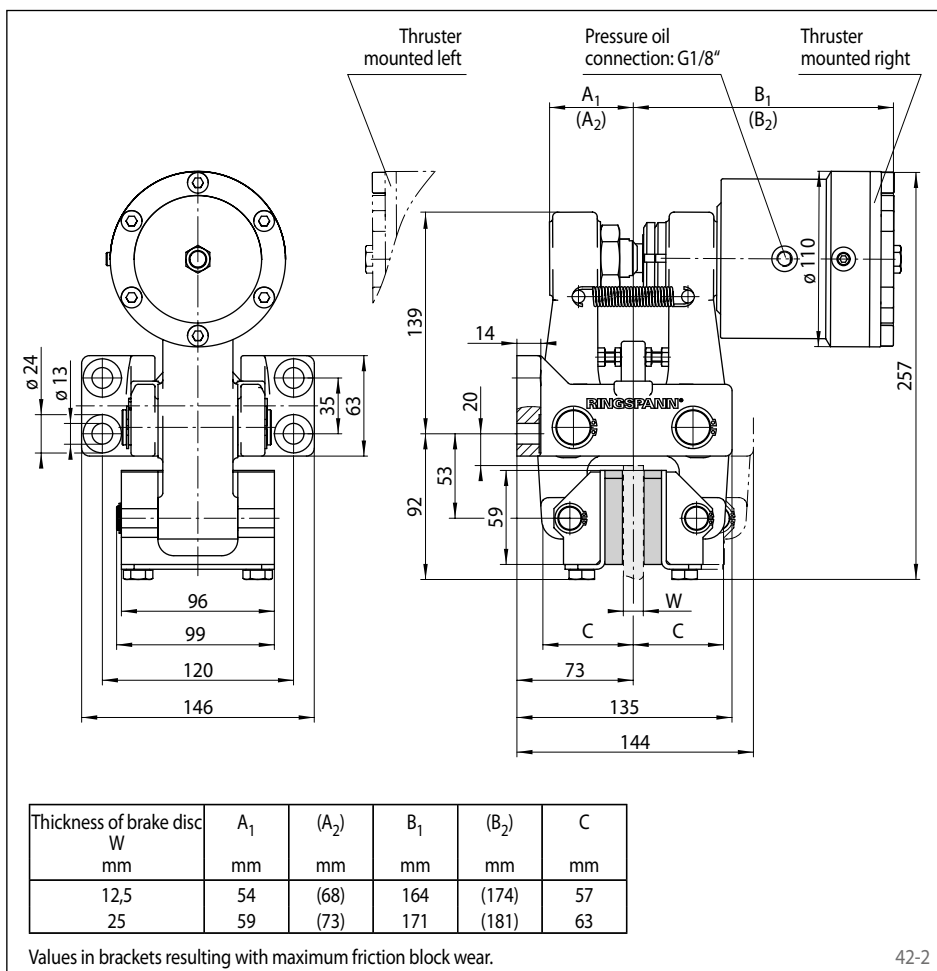

Technical Data

Brake Caliper DV 035 FHA with thruster 260	
Brake disc diameter mm	Braking torque Nm
300	1500
355	1850
430	2350
520	3000
630	3600
710	4100
800	4700
Clamping force	16000 N
Oil pressure	min. 55 bar max. 120 bar
Oil volume	max. 6 cm ³
Weight	13,9 kg

The braking torques shown in the diagram are based on a theoretical friction coefficient of 0,4.

Brake Caliper DH 035 FHA

spring activated – hydraulically released



Features

Features	Code
Brake Caliper	D
Mounting to the machine at right angles to the brake disc	H
Frame size 035	035
Spring activated	F
Hydraulically released	H
Automatic adjustment to accommodate friction block wear	A
Thruster 260	260
Thruster mounted right or left available	R L
Thickness of brake disc 12,5 mm or 25 mm	12 25

Example for ordering

Brake Caliper DH 035 FHA, thruster 260, thruster mounted right, thickness of brake disc 12,5 mm:

DH 035 FHA - 260 R - 12

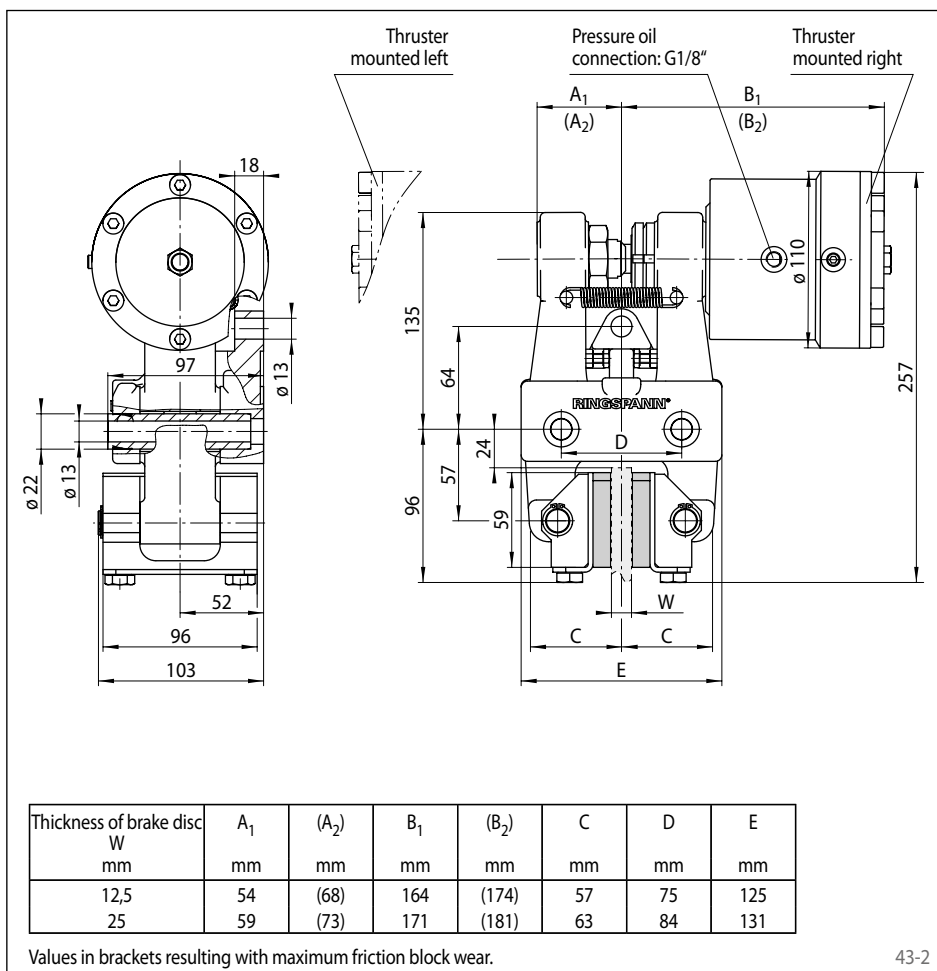

Technical Data

Brake Caliper DH 035 FHA with thruster 260	
Brake disc diameter mm	Braking torque Nm
300	1500
355	1850
430	2350
520	3000
630	3600
710	4100
800	4700
Clamping force	16000 N
Oil pressure	min. 55 bar max. 120 bar
Oil volume	max. 6 cm ³
Weight	14,1 kg

The braking torques shown in the diagram are based on a theoretical friction coefficient of 0,4.

Brake Caliper DU 060 FHM

spring activated – hydraulically released

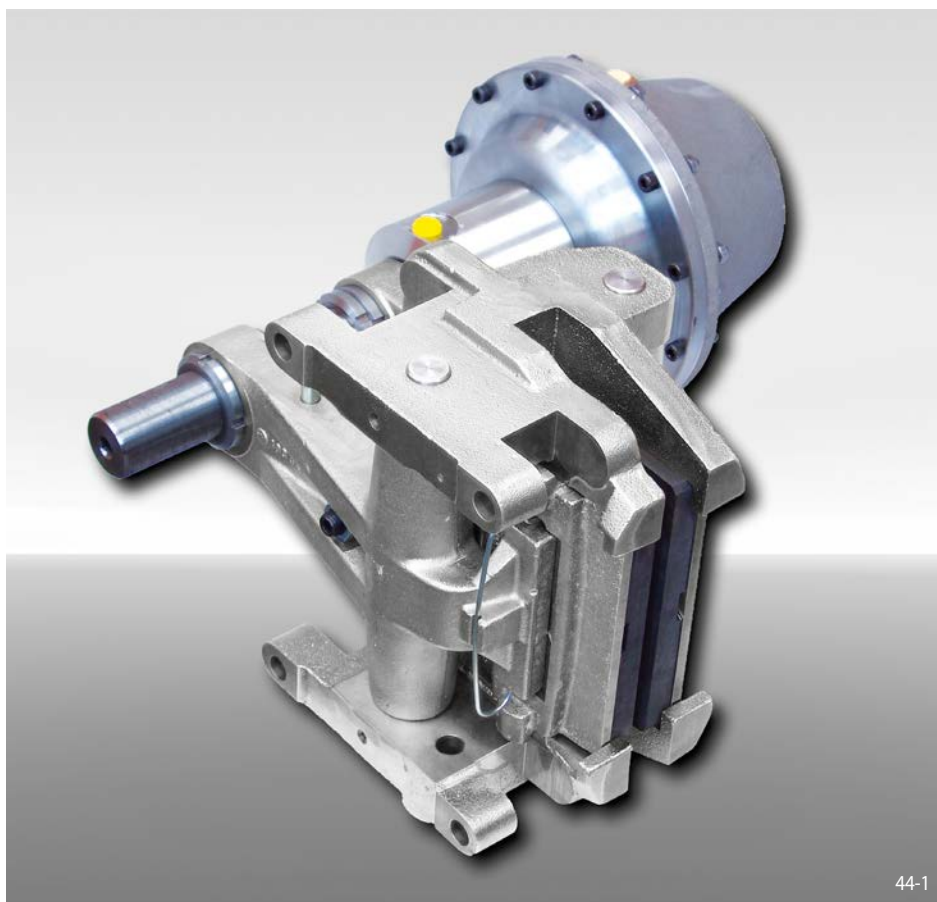

44-1

Features	Code
Brake Caliper	D
Mounting to the machine, can be made either parallel or at the right angles to the brake disc	U
Frame size 060	060
Spring activated	F
Hydraulically released	H
Manual adjustment to accommodate friction block wear	M
Thrusters 340, 350, 360 or 370 are available	340 to 370
Thruster mounted right or left available	R L
Thickness of brake disc 25 mm or 40 mm	25 40

Example for ordering

Brake Caliper DU 060 FHM, thruster 340, thruster mounted right, thickness of brake disc 25 mm:

DU 060 FHM - 340 R - 25

Technical Data

	Brake Caliper DU 060 FHM			
	with thruster 340	with thruster 350	with thruster 360	with thruster 370
Brake disc diameter	Braking torque	Braking torque	Braking torque	Braking torque
mm	Nm	Nm	Nm	Nm
630	2700	5400	7800	13500
710	3100	6200	9000	15500
800	3600	7200	10300	17500
900	4100	8300	11900	20500
1000	4700	9300	13400	23000
1250	6000	12000	17000	29500
1600	7800	15500	22500	38500
Clamping force	13200 N	26500 N	38000 N	65000 N
Oil pressure	min. 20 bar max. 125 bar	min. 30 bar max. 125 bar	min. 50 bar max. 125 bar	min. 80 bar max. 125 bar
Oil volume	max. 158 cm ³	max. 158 cm ³	max. 158 cm ³	max. 158 cm ³
Weight	71 kg	71 kg	71 kg	71 kg

The braking torques shown in the diagram are based on a theoretical friction coefficient of 0.4.

Brake Caliper DU 060 FHM

spring activated – hydraulically released

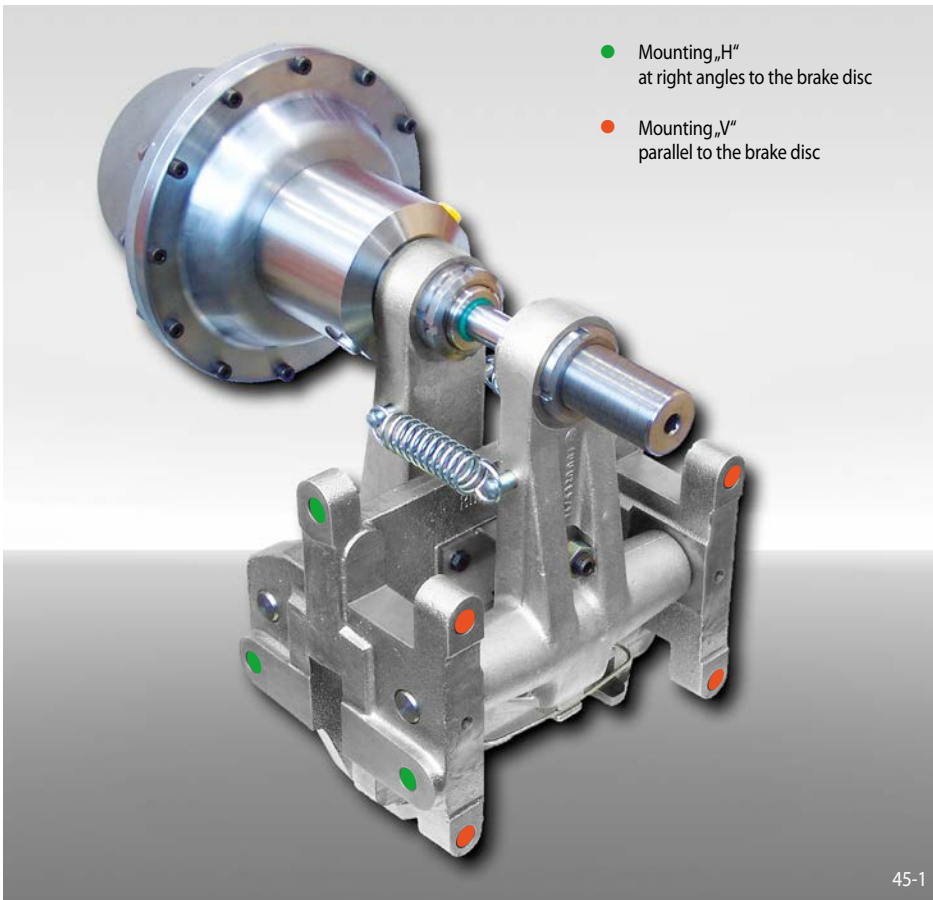

- Mounting „H“ at right angles to the brake disc
- Mounting „V“ parallel to the brake disc

Frame Design

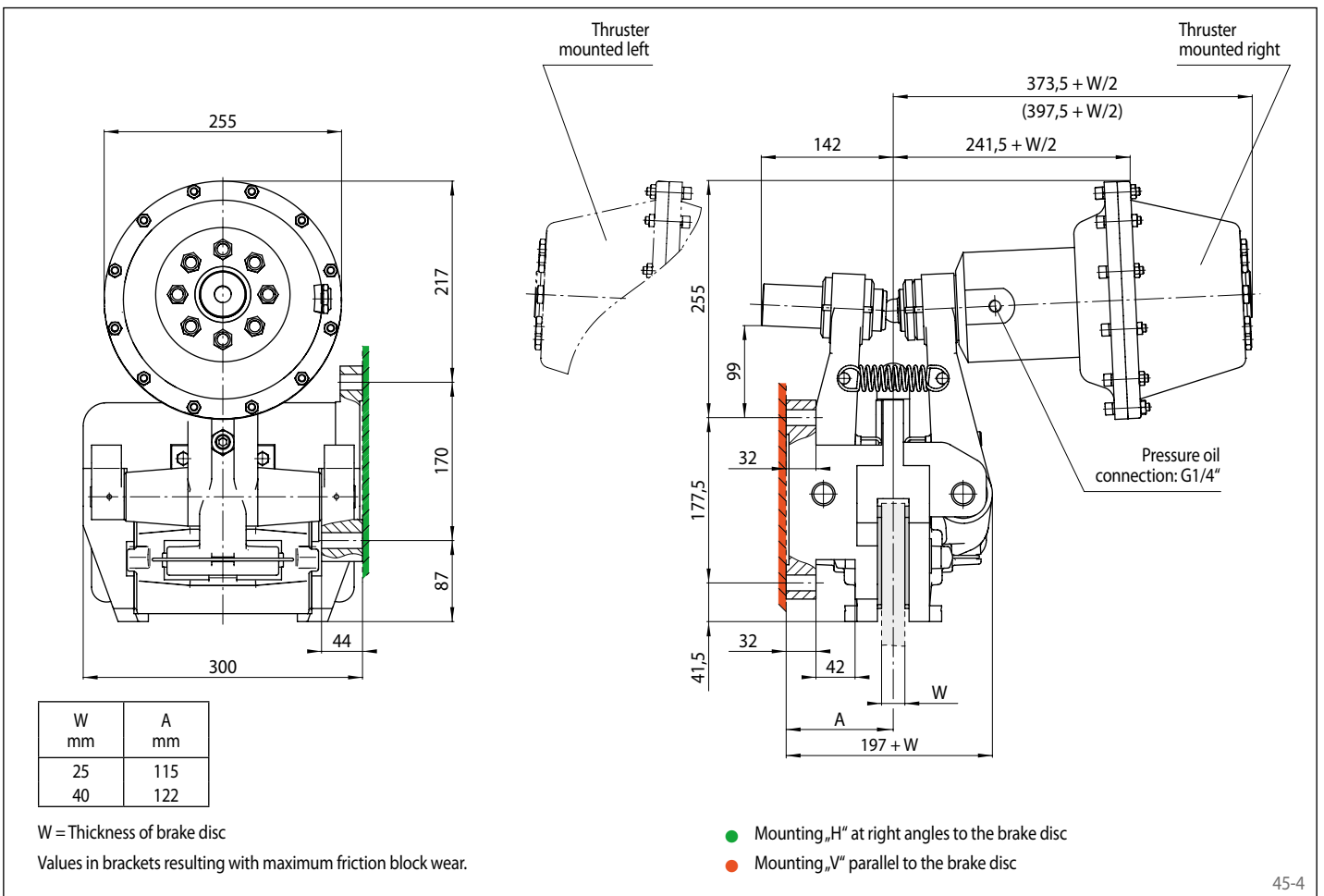
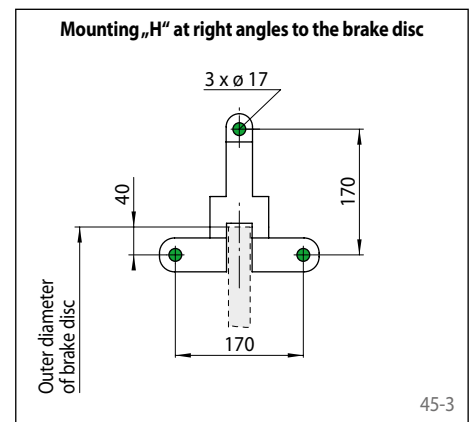
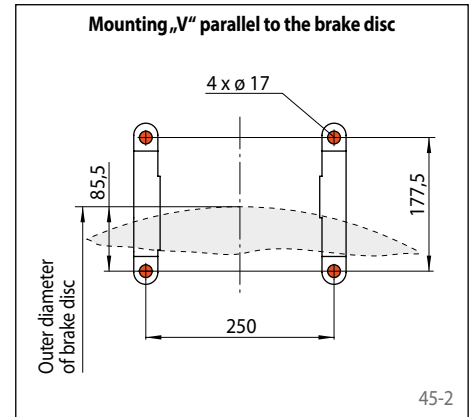

Brake Caliper DV 020 FKM

spring activated – manually released
by Pull Cable

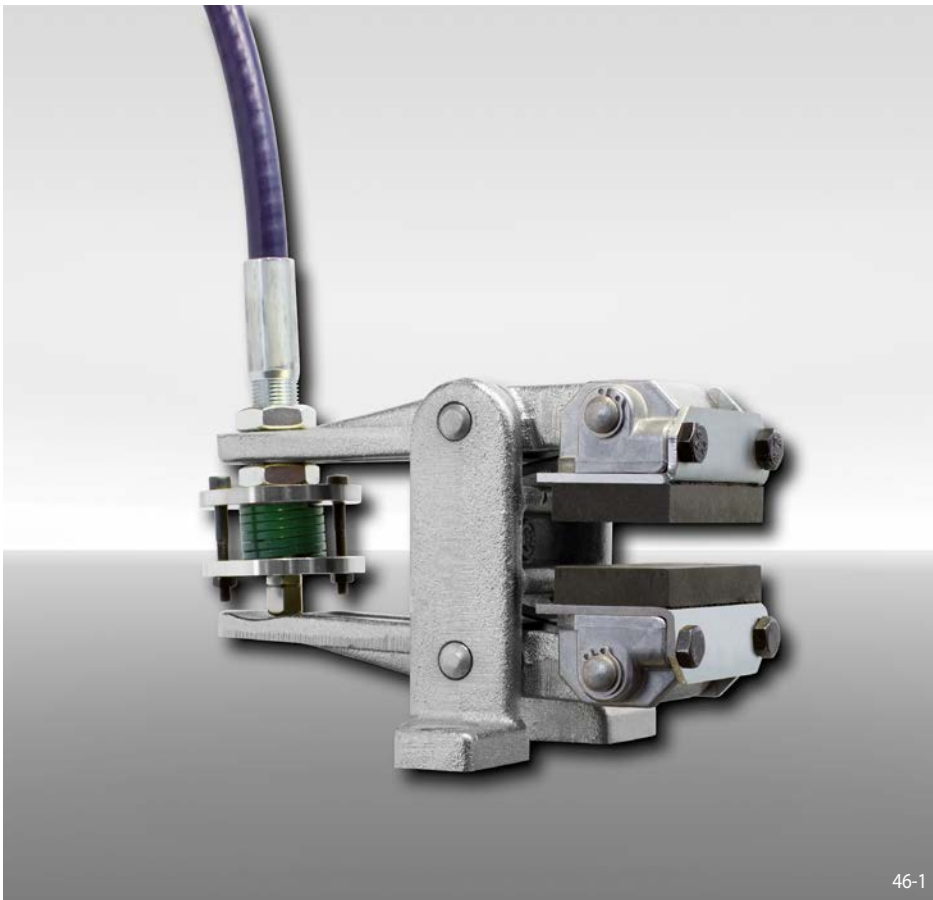

46-1

Features

Features	Code
Brake Caliper	D
Mounting to the machine parallel to the brake disc	V
Frame size 020	020
Spring activated	F
Manually released	K
Manual adjustment to accommodate friction block wear	M
Pressure spring 510	510
Pull Cable installation mounted right or left available	R L
Thickness of brake disc 12,5 mm	12

Example for ordering

Brake Caliper DV 020 FKM, pressure spring 510, Pull Cable installation mounted right, thickness of brake disc 12,5 mm:

DV 020 FKM - 510 R - 12

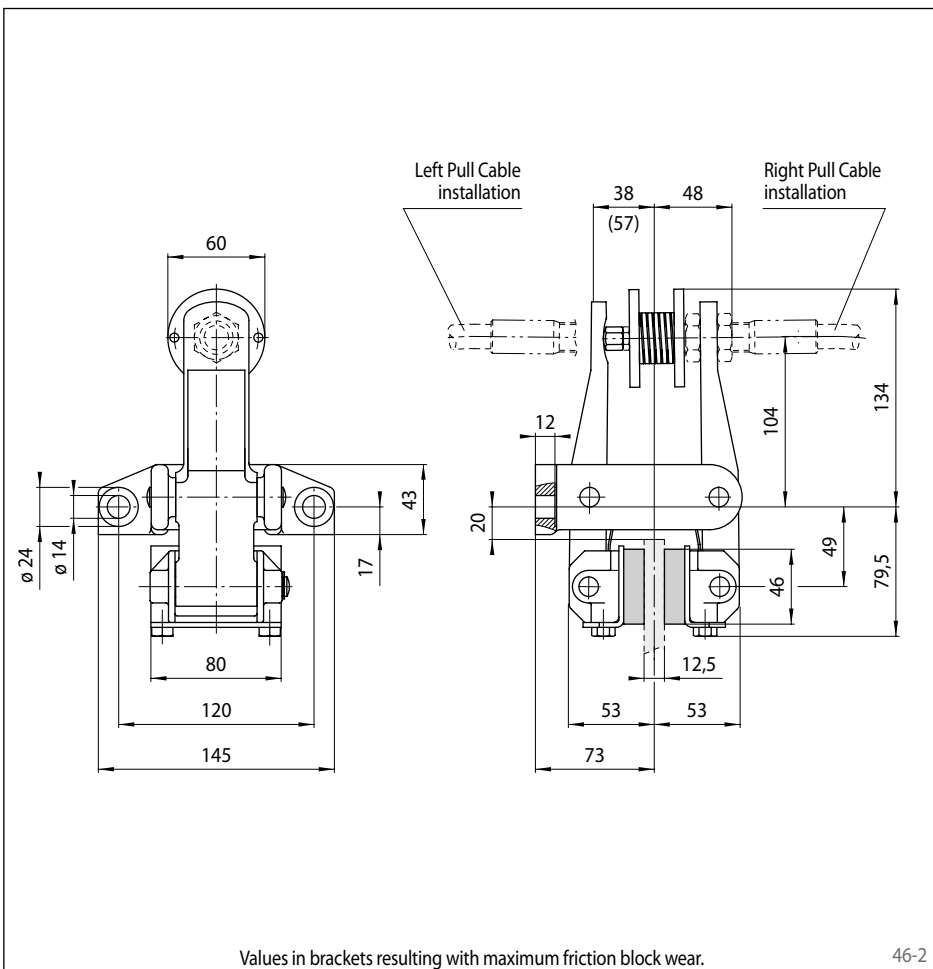

Values in brackets resulting with maximum friction block wear.

46-2

Technical Data

Brake Caliper DV 020 FKM with pressure spring 510	
Brake disc diameter	Braking torque
mm	Nm
200	160
250	210
300	270
355	330
430	410
520	510
Clamping force	2750 N
Weight	4,4 kg

The braking torques shown in the diagram are based on a theoretical friction coefficient of 0,4.

Accessories

The Brake Caliper can be delivered fully assembled with RCS® Pull Cable and Hand Brake Lever. Please indicate the required cable length.

For further information regarding RCS® Pull Cable and Hand Brake Lever see page 197.

Brake Caliper DH 020 FKM

spring activated – manually released
by Pull Cable



47-1

Features

Features	Code
Brake Caliper	D
Mounting to the machine at right angles to the brake disc	H
Frame size 020	020
Spring activated	F
Manually released	K
Manual adjustment to accommodate friction block wear	M
Pressure spring 510	510
Position of the Pull Cable installation to the right or left can be defined by turning the brake during installation	U
Thickness of brake disc 12,5 mm	12

Example for ordering

Brake Caliper DH 020 FKM, pressure spring 510, position of the Pull Cable installation can be to the right or left, thickness of brake disc 12,5 mm:

DH 020 FKM - 510 U - 12

Technical Data

Brake Caliper DH 020 FKM with pressure spring 510	
Brake disc diameter	Braking torque
mm	Nm
200	160
250	210
300	270
355	330
430	410
520	510
Clamping force	2750 N
Weight	4,4 kg

The braking torques shown in the diagram are based on a theoretical friction coefficient of 0,4.

Accessories

The Brake Caliper can be delivered fully assembled with RCS® Pull Cable and Hand Brake Lever. Please indicate the required cable length.

For further information regarding RCS® Pull Cable and Hand Brake Lever see page 197.

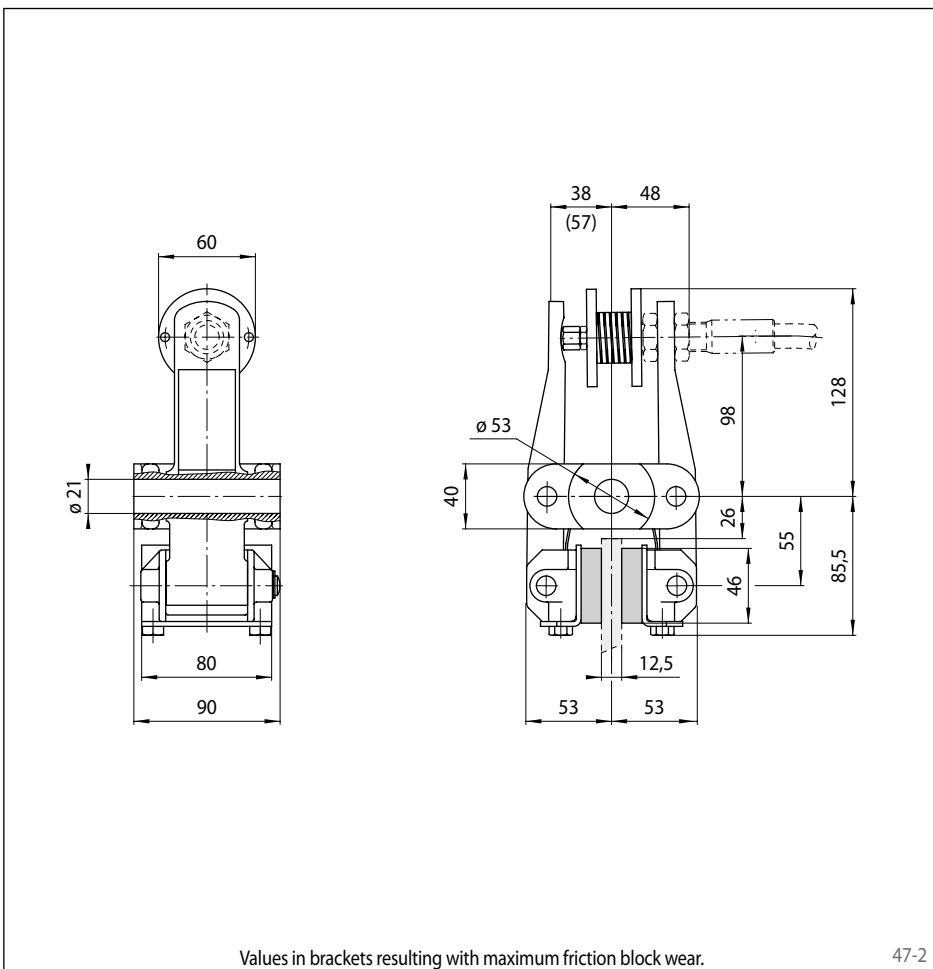

Values in brackets resulting with maximum friction block wear.

47-2

Brake Caliper DH 005 PFK

pneumatically activated – spring released



Features

Features	Code
Brake Caliper	D
Mounting to the machine at right angles to the brake disc	H
Frame size 005	005
Pneumatically activated	P
Spring released	F
No adjustment to accommodate friction block wear	K
Pressure piston 605	605
Pressure piston mounted in central position	M
Thickness of brake disc 6 mm	06

Example for ordering

Brake Caliper DH 005 PFK, pressure piston 605, Pressure piston mounted in central position, thickness of brake disc 6 mm:

DH 005 PFK - 605 M - 06

Technical Data

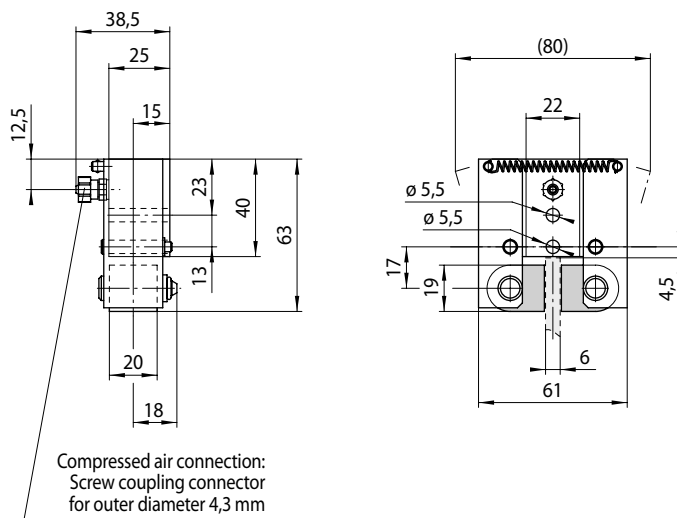

Values in brackets resulting with maximum friction block wear.

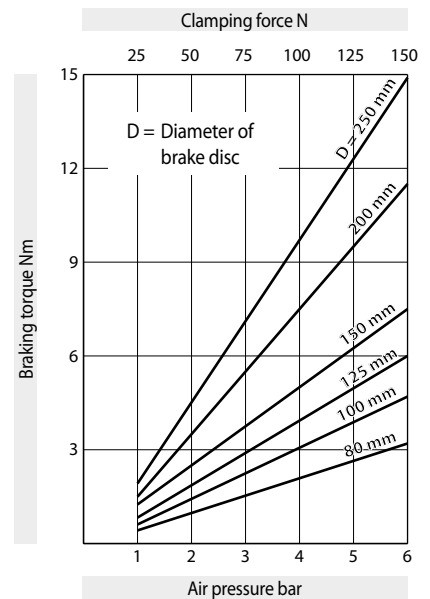

The braking torques shown in the diagram are based on a theoretical friction coefficient of 0,4.

Air pressure: max. 6 bar

Air volume: max. 3 cm³ per activation

Weight: 0,4 kg

49-1

49-2

Brake Caliper DH 010 PFK

pneumatically activated – spring released



Features

Features	Code
Brake Caliper	D
Mounting to the machine at right angles to the brake disc	H
Frame size 010	010
Pneumatically activated	P
Spring released	F
No adjustment to accommodate friction block wear	K
Pressure piston 610	610
Pressure piston mounted in central position	M
Thickness of brake disc 12,5 mm	12

Example for ordering

Brake Caliper DH 010 PFK, pressure piston 610, Pressure piston mounted in central position, thickness of brake disc 12,5 mm:

DH 010 PFK - 610 M - 12

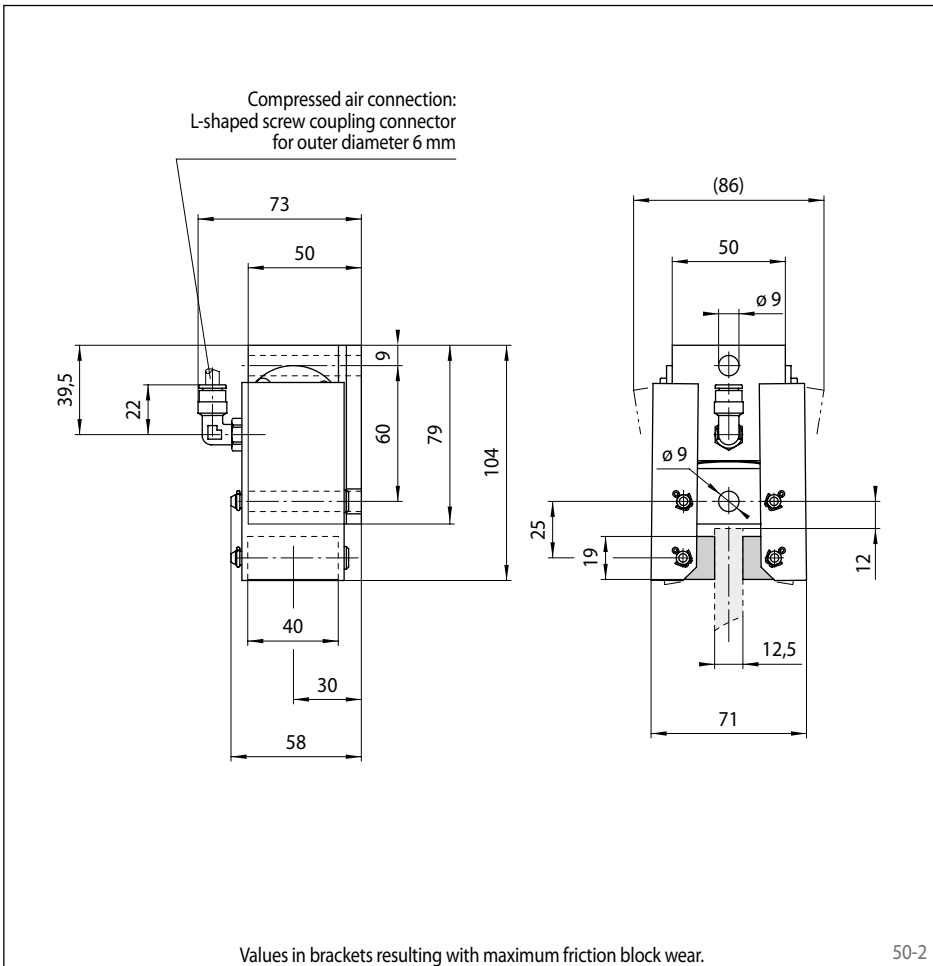

Technical Data

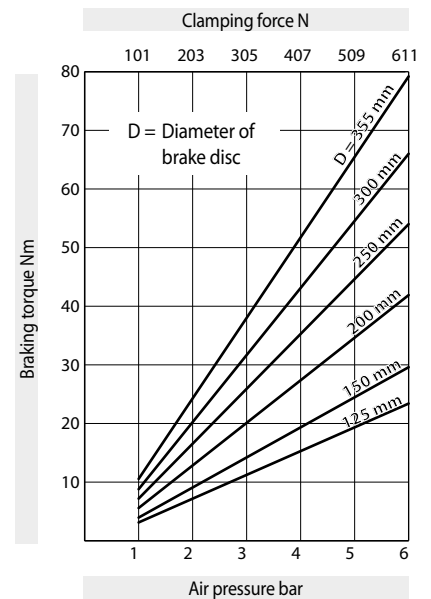

The braking torques shown in the diagram are based on a theoretical friction coefficient of 0,4.

Air pressure: max. 6 bar

Air volume: max. 10 cm³ per activation

Weight: 1,1 kg

Brake Caliper DH 015 PFK

pneumatically activated – spring released

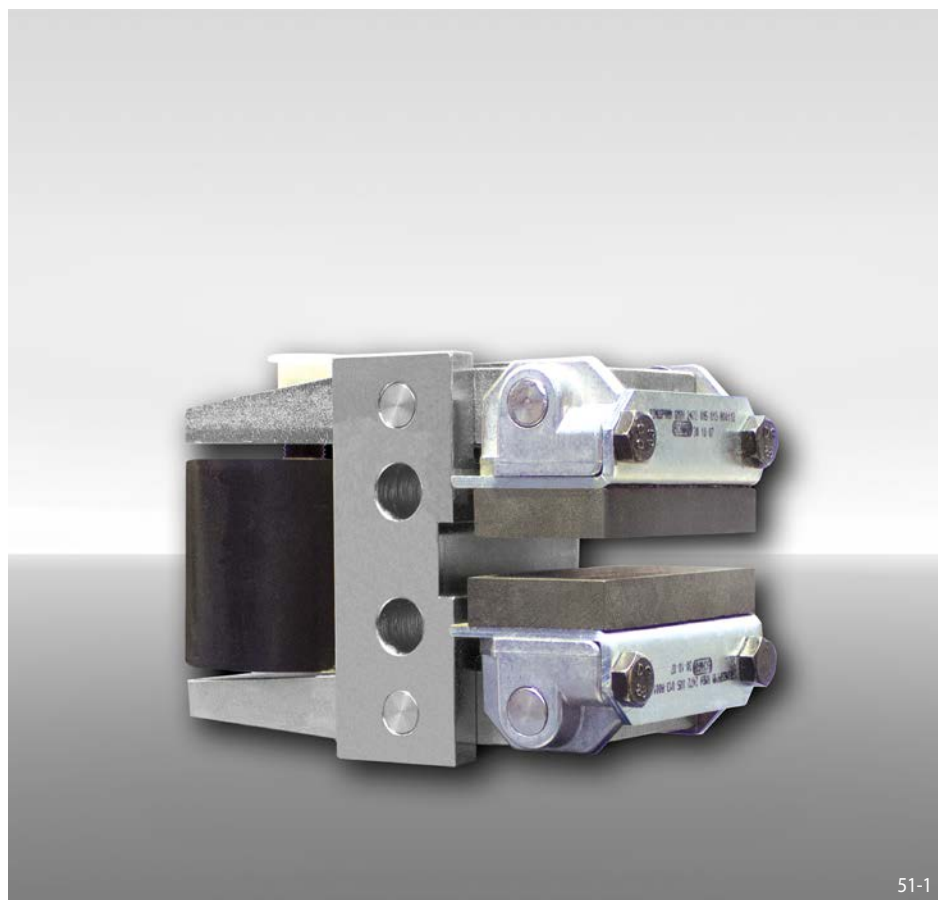

Features	Code
Brake Caliper	D
Mounting to the machine at right angles to the brake disc	H
Frame size 015	015
Pneumatically activated	P
Spring released	F
No adjustment to accommodate friction block wear	K
Thruster 620	620
Thruster mounted in central position	M
Thickness of brake disc 12,5 mm	12

Example for ordering

Brake Caliper DH 015 PFK, thruster 620, thruster mounted in central position, thickness of brake disc 12,5 mm:

DH 015 PFK - 620 M - 12

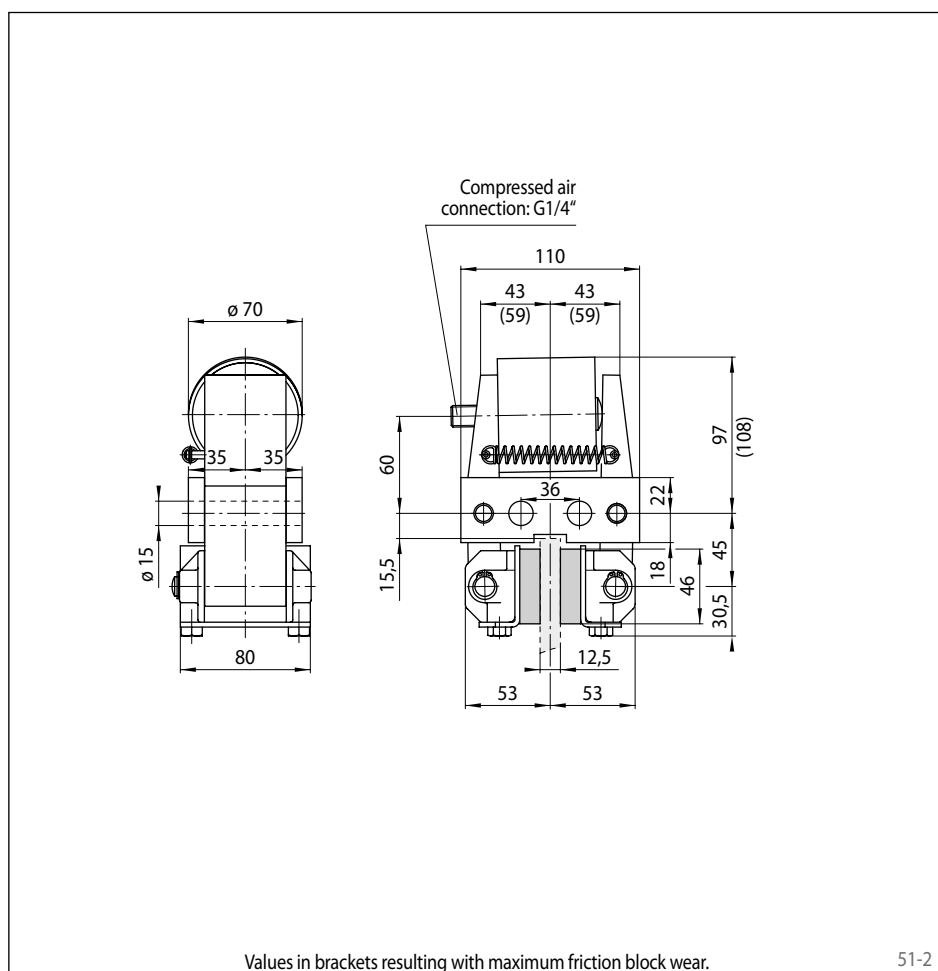

Technical Data

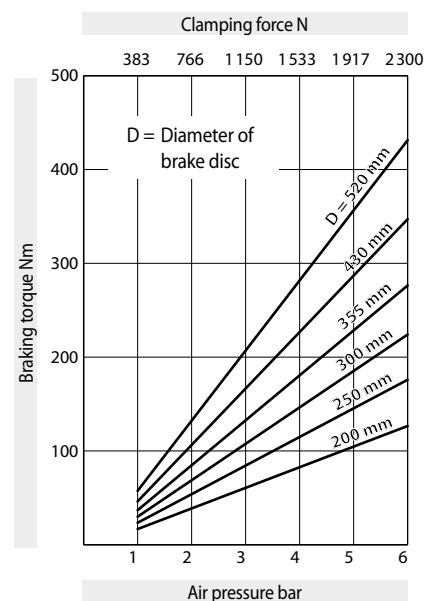

The braking torques shown in the diagram are based on a theoretical friction coefficient of 0,4.

Air pressure: max. 6 bar

Air volume: max. 124 cm³ per activation

Weight: 4,6 kg

Brake Caliper DV 020 PFK

pneumatically activated – spring released



52-1

Features

Features	Code
Brake Caliper	D
Mounting to the machine parallel to the brake disc	V
Frame size 020	020
Pneumatically activated	P
Spring released	F
No adjustment to accommodate friction block wear	K
Thruster 630	630
Thruster mounted in central position	M
Thickness of brake disc 12,5 mm	12

Example for ordering

Brake Caliper DV 020 PFK, thruster 630, thruster mounted in central position, thickness of brake disc 12,5 mm:

DV 020 PFK - 630 M - 12

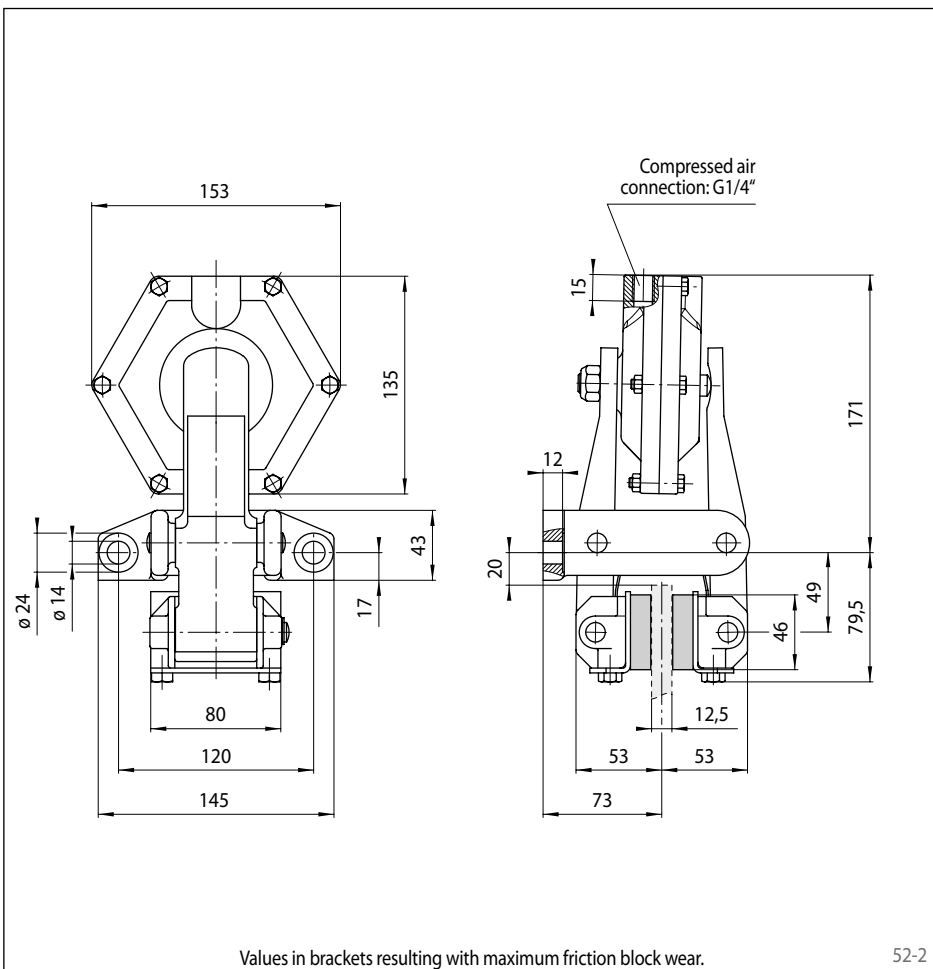

52-2

Technical Data

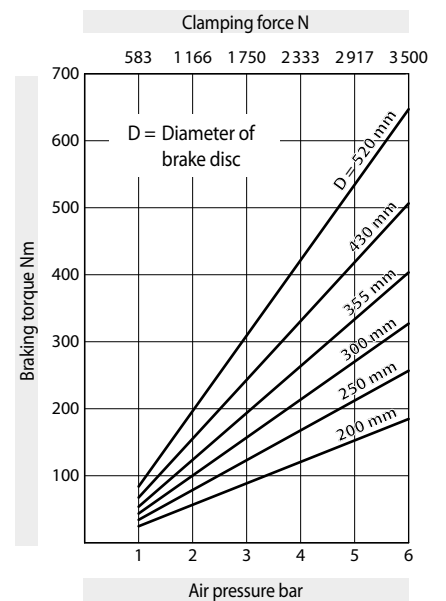

The braking torques shown in the diagram are based on a theoretical friction coefficient of 0,4.

Air pressure: max. 6 bar

Air volume: max. 120 cm³ per activation

Weight: 4,8 kg

Brake Caliper DH 020 PFK

pneumatically activated – spring released



Features

Features	Code
Brake Caliper	D
Mounting to the machine at right angles to the brake disc	H
Frame size 020	020
Pneumatically activated	P
Spring released	F
No adjustment to accommodate friction block wear	K
Thruster 630	630
Thruster mounted in central position	M
Thickness of brake disc 12,5 mm	12

Example for ordering

Brake Caliper DH 020 PFK, thruster 630, thruster mounted in central position, thickness of brake disc 12,5 mm:

DH 020 PFK - 630 M - 12

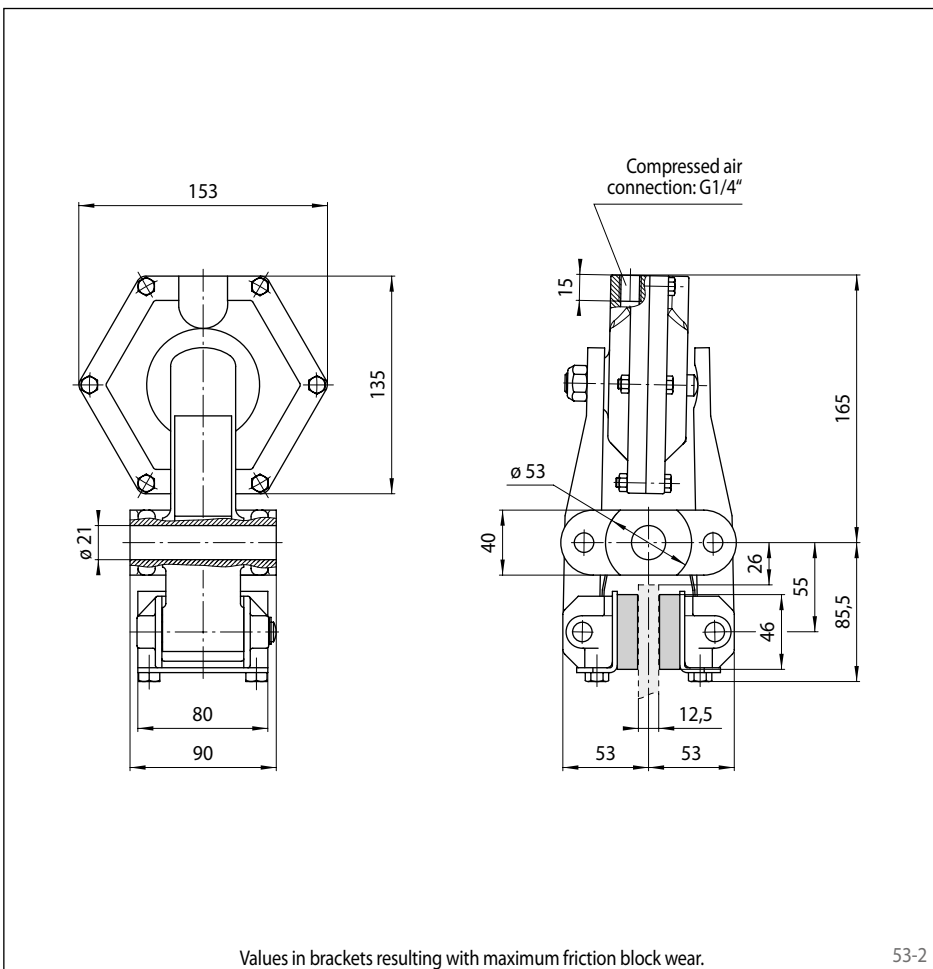

Technical Data

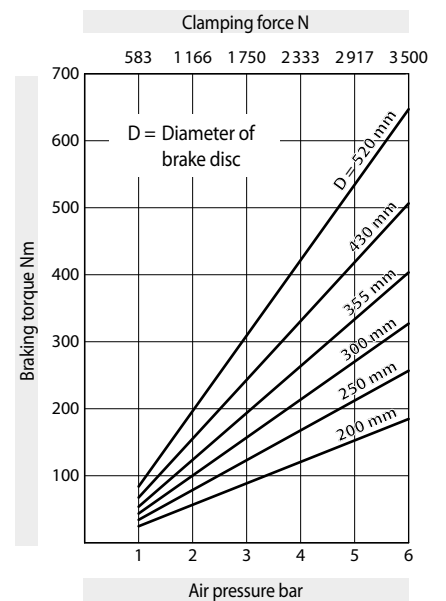

The braking torques shown in the diagram are based on a theoretical friction coefficient of 0,4.

Air pressure: max. 6 bar

Air volume: max. 120 cm³ per activation

Weight: 4,8 kg

Brake Caliper DH 025 PFM

pneumatically activated – spring released



Features	Code
Brake Caliper	D
Mounting to the machine at right angles to the brake disc	H
Frame size 025	025
Pneumatically activated	P
Spring released	F
Manual adjustment to accommodate friction block wear	M
Thrusters 635 or 655 are available	635 655
Thruster mounted right or left available	R L
Thickness of brake disc 12,5 mm or 25 mm	12 25

Example for ordering

Brake Caliper DH 025 PFM, thruster 635, thruster mounted right, thickness of brake disc 12,5 mm:

DH 025 PFM - 635 R - 12

Technical Data

Brake Caliper DH 025 PFM - 635

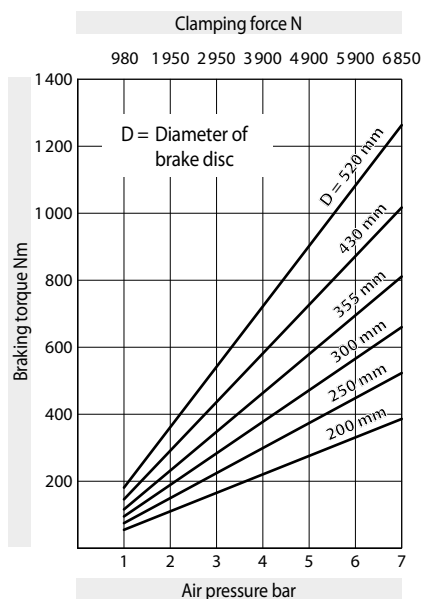

The braking torques shown in the diagram are based on a theoretical friction coefficient of 0,4.

Air pressure: max. 7 bar

Air volume: max. 175 cm³ per activation

Weight: 7,1 kg

Brake Caliper DH 025 PFM - 655

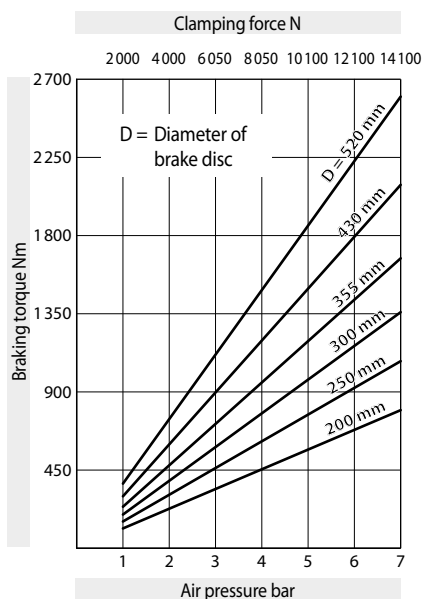

The braking torques shown in the diagram are based on a theoretical friction coefficient of 0,4.

Air pressure: max. 7 bar

Air volume: max. 740 cm³ per activation

Weight: 10,3 kg

Brake Caliper DH 025 PFM

pneumatically activated – spring released

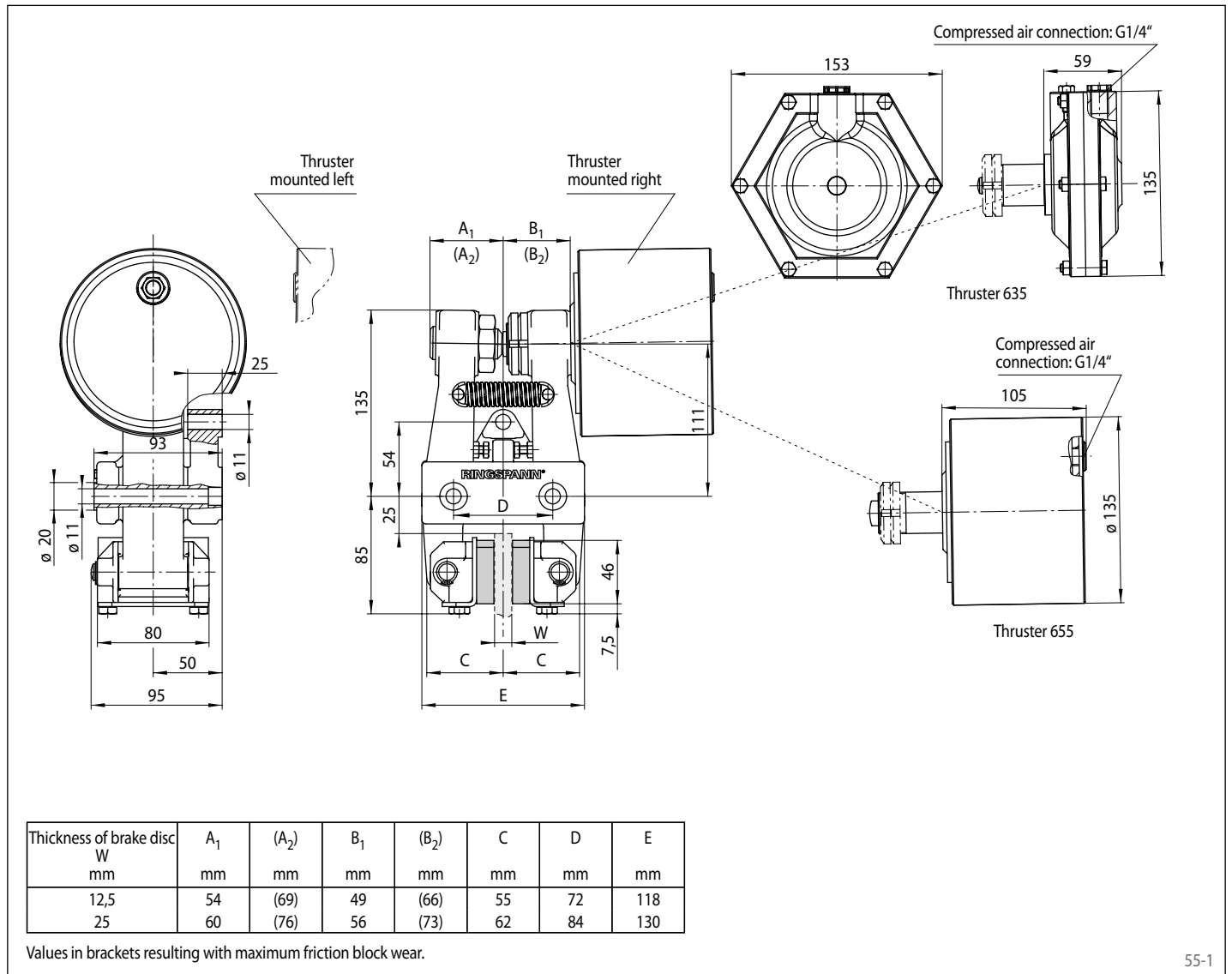

Brake Caliper DV 030 PFM

pneumatically activated – spring released

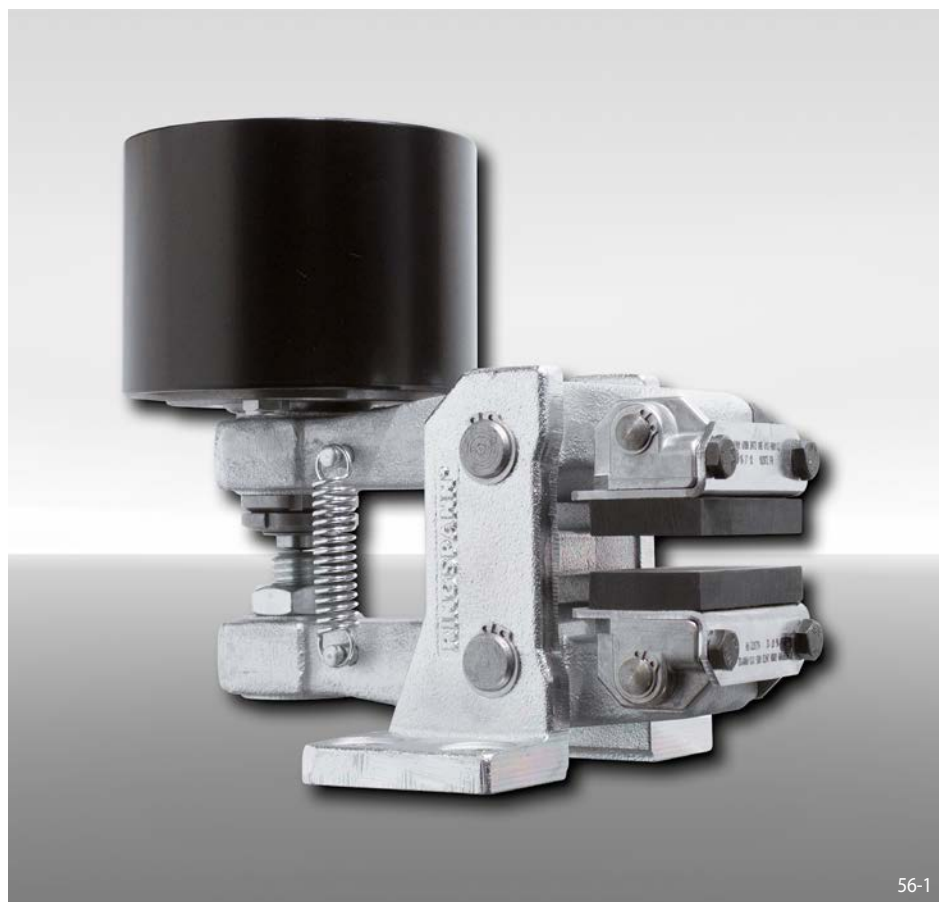

Features	Code
Brake Caliper	D
Mounting to the machine parallel to the brake disc	V
Frame size 030	030
Pneumatically activated	P
Spring released	F
Manual adjustment to accommodate friction block wear	M
Thrusters 635 or 655 are available	635 655
Thruster mounted right or left available	R L
Thickness of brake disc 12,5 mm or 25 mm	12 25

Example for ordering

Brake Caliper DV 030 PFM, thruster 635, thruster mounted right, thickness of brake disc 12,5 mm:

DV 030 PFM - 635 R - 12

Technical Data

Brake Caliper DV 030 PFM - 635

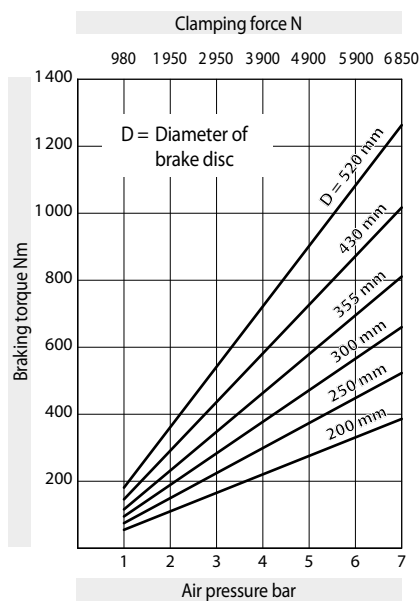

The braking torques shown in the diagram are based on a theoretical friction coefficient of 0,4.

Air pressure: max. 7 bar

Air volume: max. 175 cm³ per activation

Weight: 7,3 kg

Brake Caliper DV 030 PFM - 655

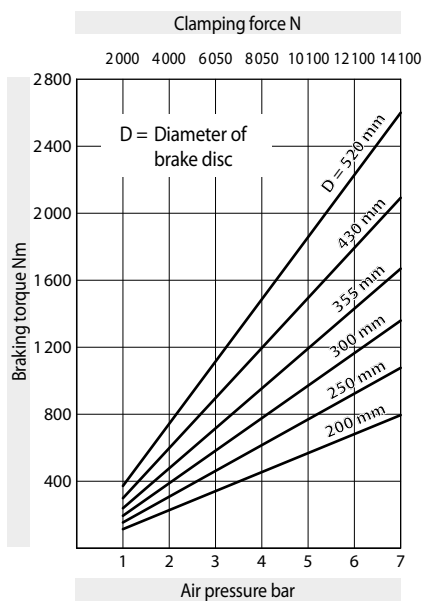

The braking torques shown in the diagram are based on a theoretical friction coefficient of 0,4.

Air pressure: max. 7 bar

Air volume: max. 740 cm³ per activation

Weight: 10,5 kg

Brake Caliper DV 030 PFM

pneumatically activated – spring released

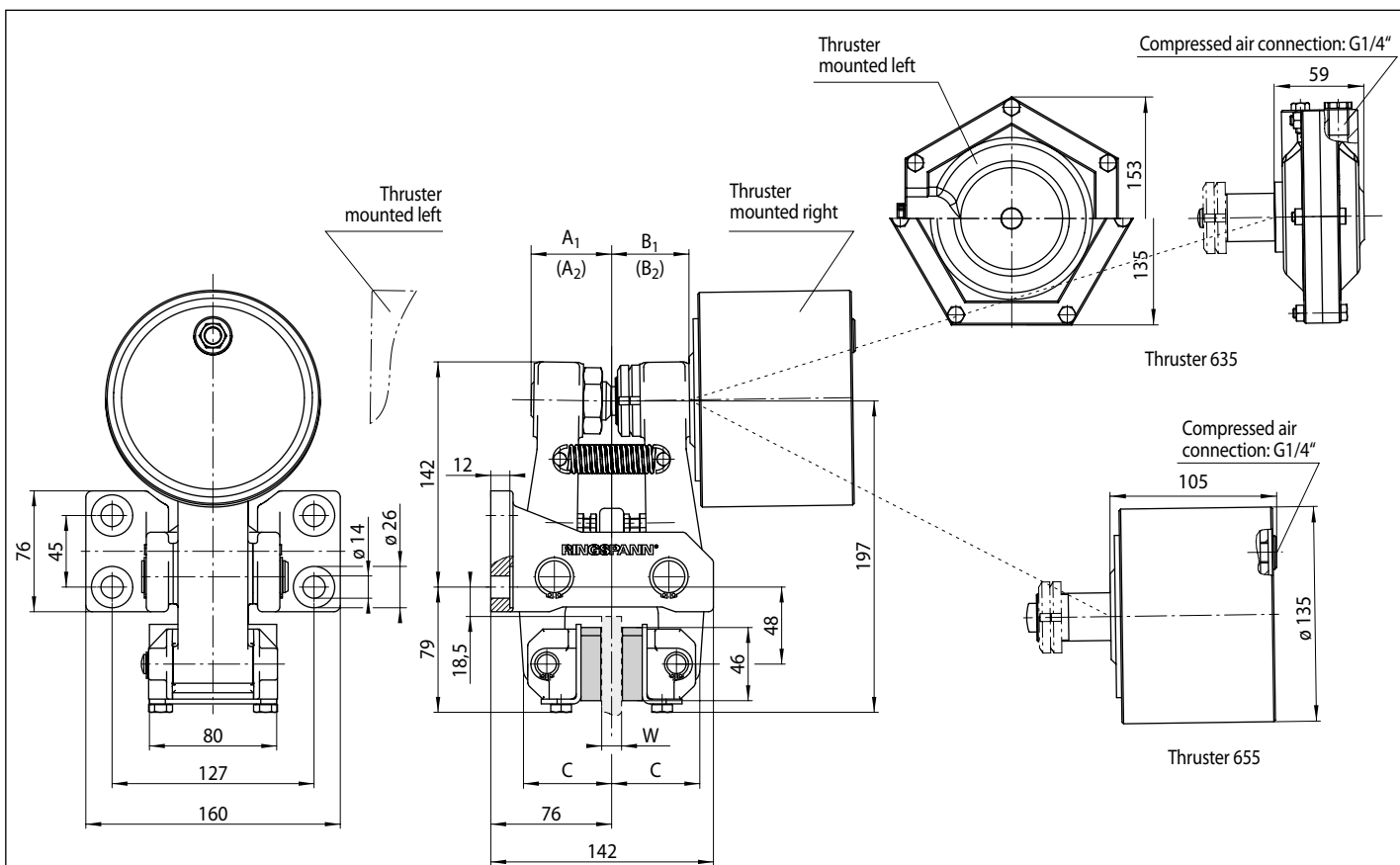

Thickness of brake disc W mm	A ₁ mm	(A ₂) mm	B ₁ mm	(B ₂) mm	C mm
12,5	54	(69)	49	(66)	55
25	60	(76)	56	(73)	62

Values in brackets resulting with maximum friction block wear.

Brake Caliper DH 030 PFM

pneumatically activated – spring released



Features

Features	Code
Brake Caliper	D
Mounting to the machine at right angles to the brake disc	H
Frame size 030	030
Pneumatically activated	P
Spring released	F
Manual adjustment to accommodate friction block wear	M
Thrusters 635 or 655 are available	635 655
Thruster mounted right or left available	R L
Thickness of brake disc 12,5 mm or 25 mm	12 25

Example for ordering

Brake Caliper DH 030 PFM, thruster 635, thruster mounted right, thickness of brake disc 12,5 mm:

DH 030 PFM - 635 R - 12

Technical Data

Brake Caliper DH 030 PFM - 635

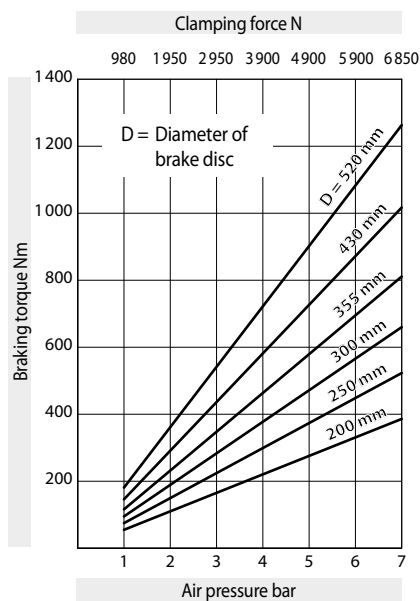

The braking torques shown in the diagram are based on a theoretical friction coefficient of 0,4.

Air pressure: max. 7 bar

Air volume: max. 175 cm³ per activation

Weight: 7,7 kg

Brake Caliper DH 030 PFM - 655

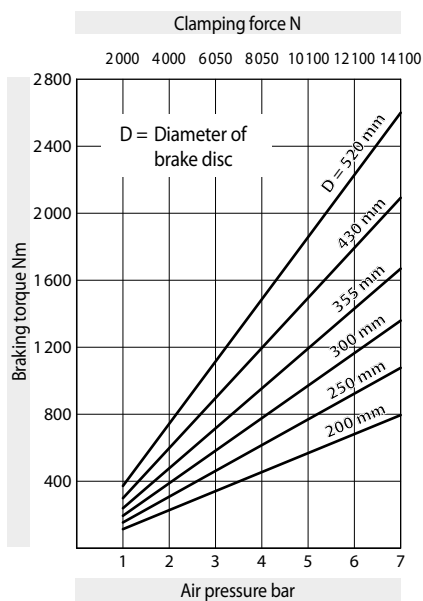

The braking torques shown in the diagram are based on a theoretical friction coefficient of 0,4.

Air pressure: max. 7 bar

Air volume: max. 740 cm³ per activation

Weight: 10,9 kg

Brake Caliper DH 030 PFM

pneumatically activated – spring released

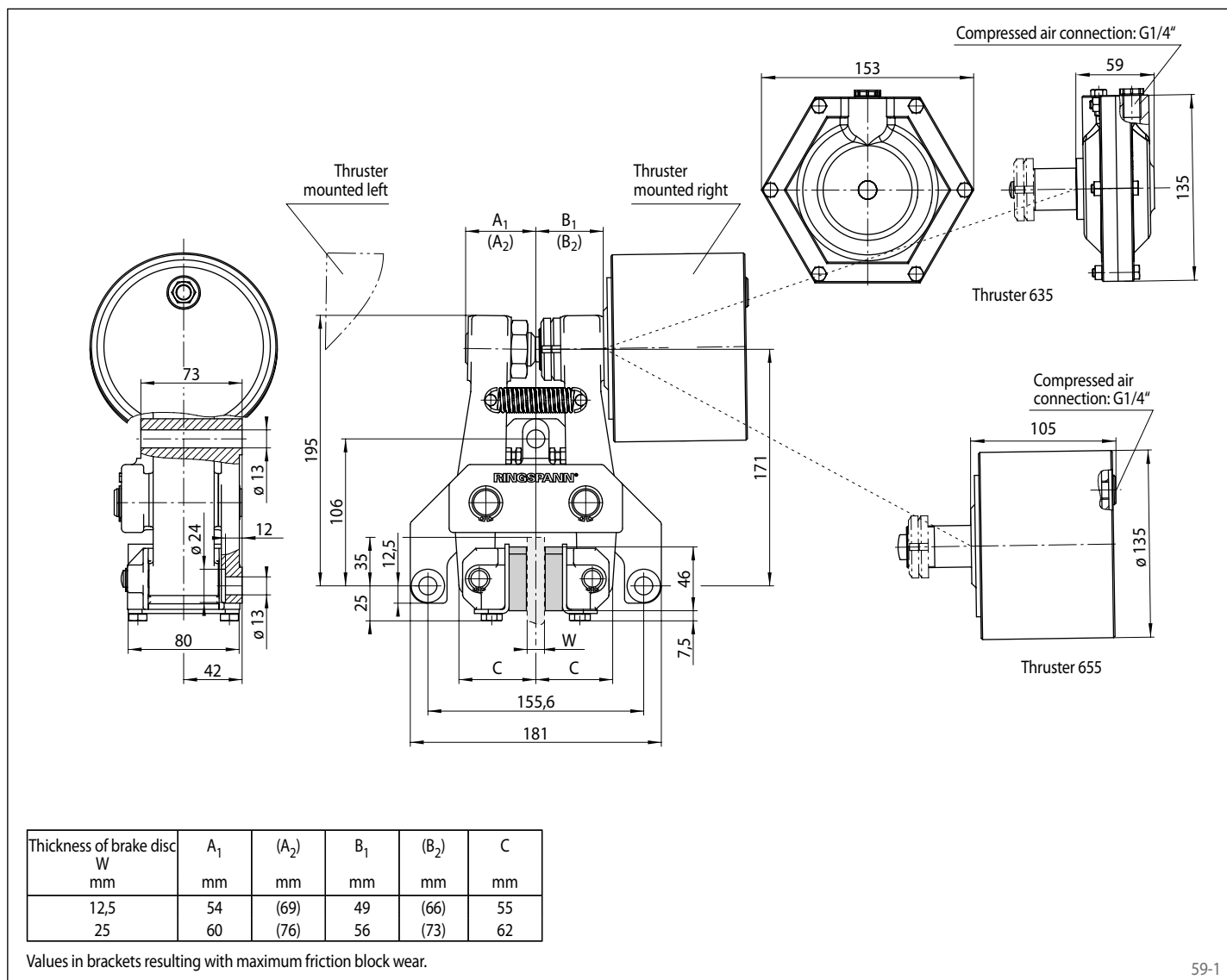

Brake Caliper DV 035 PFM

pneumatically activated – spring released

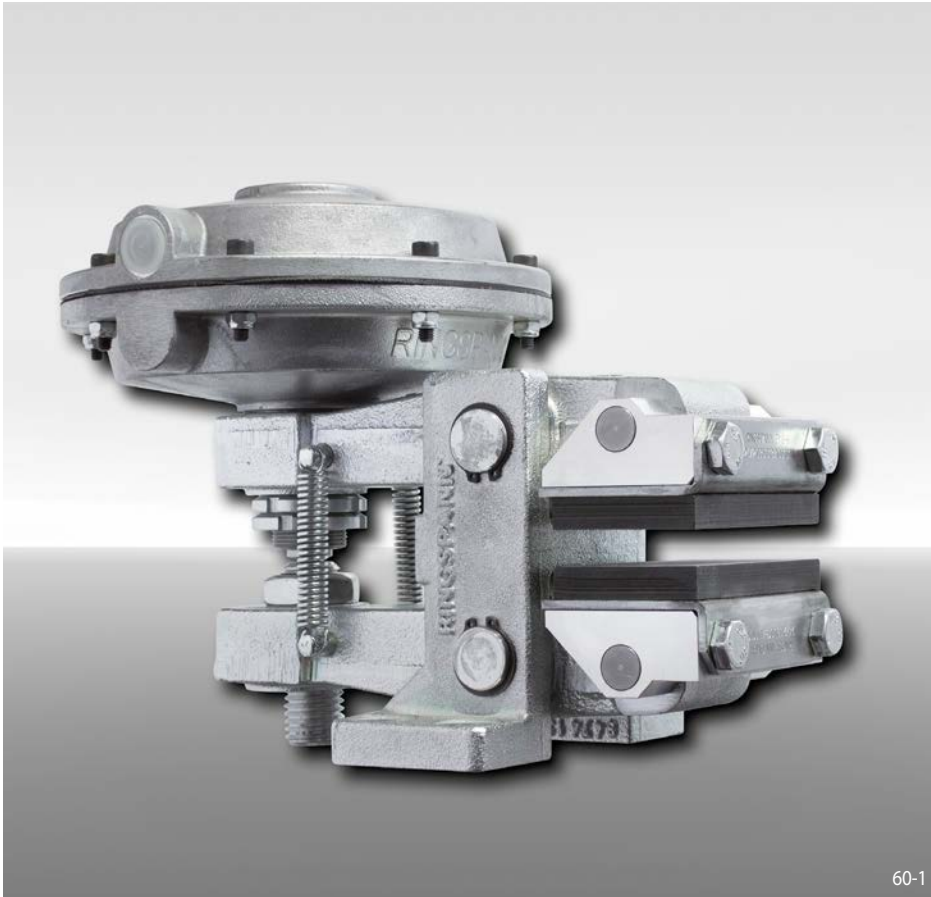

Features

Features	Code
Brake Caliper	D
Mounting to the machine parallel to the brake disc	V
Frame size 035	035
Pneumatically activated	P
Spring released	F
Manual adjustment to accommodate friction block wear	M
Thrusters 635, 655 or 660 are available	635 655 660
Thruster mounted right available	R
Thickness of brake disc 12,5 mm, 25 mm, 30 mm or 40 mm	12 to 40

Example for ordering

Brake Caliper DV 035 PFM, thruster 660, thruster mounted right, thickness of brake disc 12,5 mm:

DV 035 PFM - 660 R - 12

Technical Data

Brake Caliper DV 035 PFM - 635

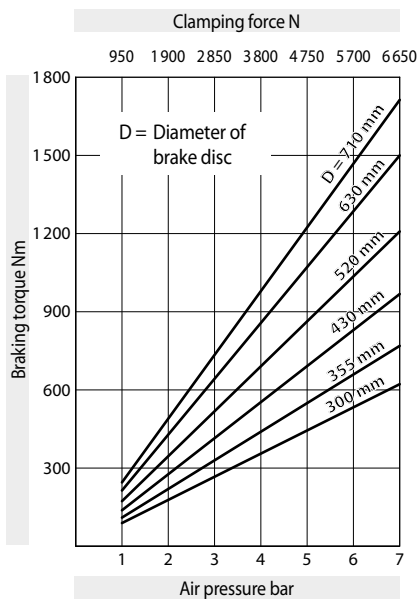

The braking torques shown in the diagram are based on a theoretical friction coefficient of 0,4.

Air pressure: max. 7 bar

Air volume: max. 175 cm³ per activation

Weight: 9,1 kg

Brake Caliper DV 035 PFM - 655

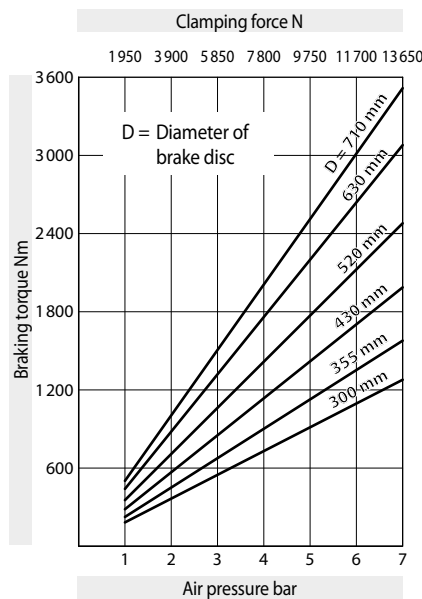

The braking torques shown in the diagram are based on a theoretical friction coefficient of 0,4.

Air pressure: max. 7 bar

Air volume: max. 740 cm³ per activation

Weight: 12,3 kg

Brake Caliper DV 035 PFM - 660

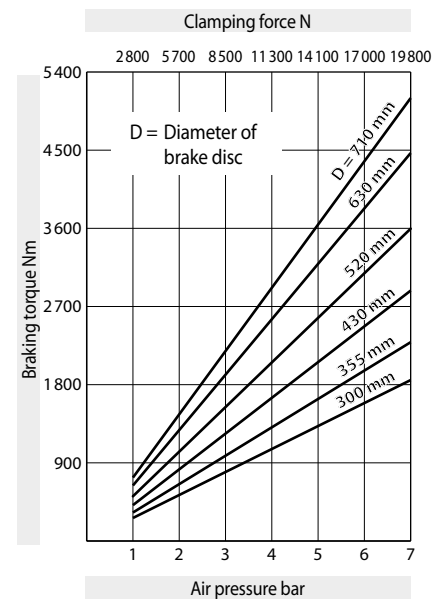

The braking torques shown in the diagram are based on a theoretical friction coefficient of 0,4.

Air pressure: max. 7 bar

Air volume: max. 450 cm³ per activation

Weight: 11,4 kg

Brake Caliper DV 035 PFM

pneumatically activated – spring released

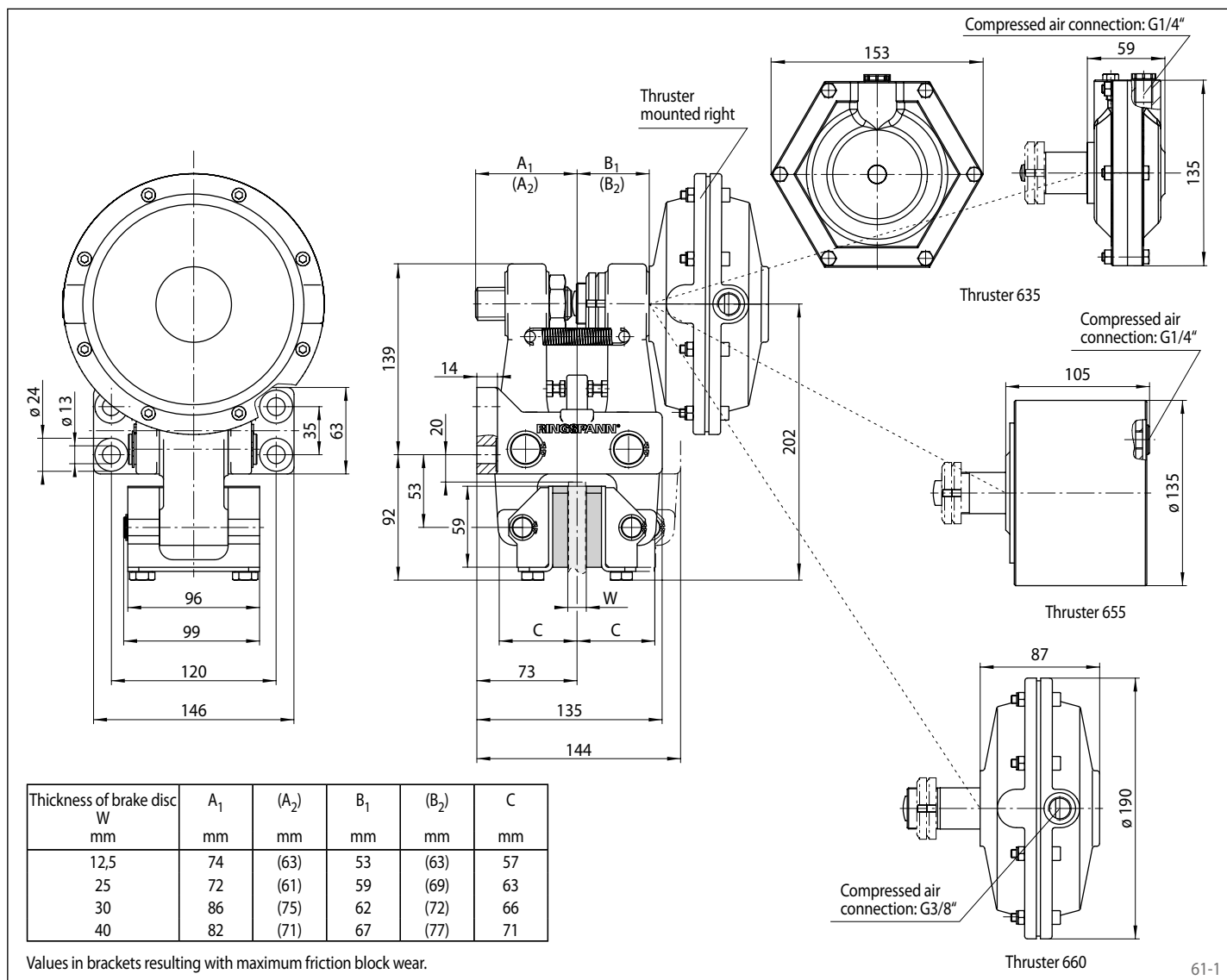

Brake Caliper DH 035 PFM

pneumatically activated – spring released

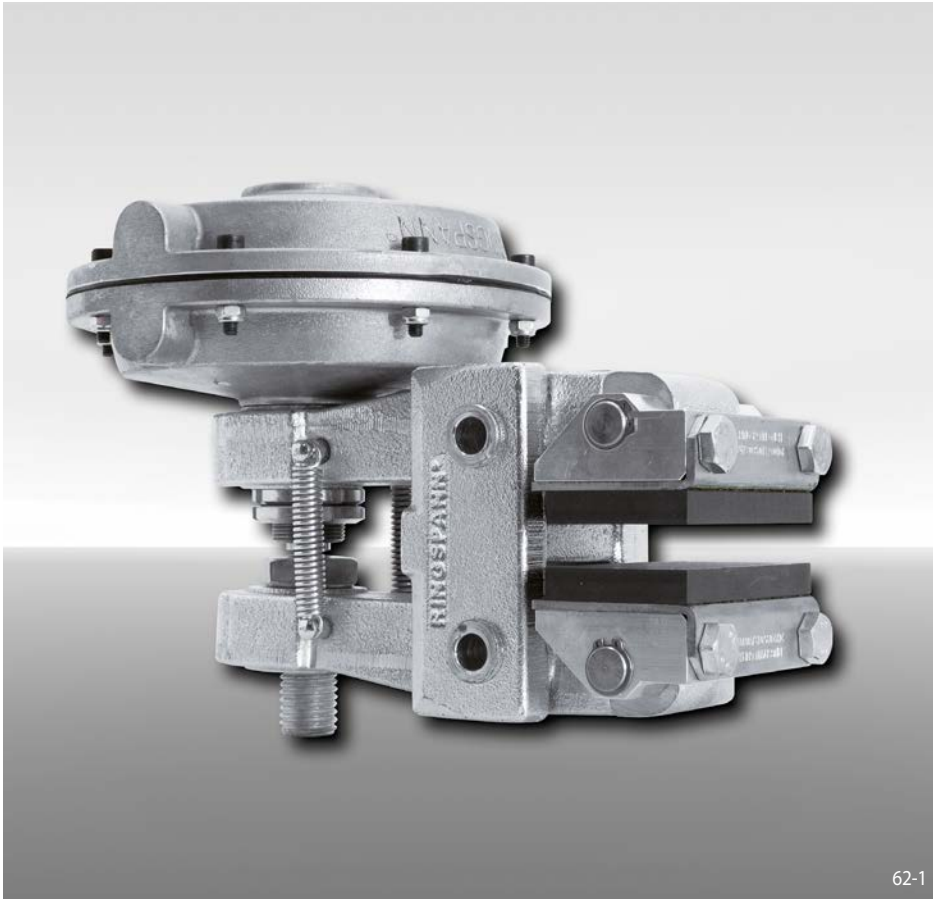

Features

Features	Code
Brake Caliper	D
Mounting to the machine at right angles to the brake disc	H
Frame size 035	035
Pneumatically activated	P
Spring released	F
Manual adjustment to accommodate friction block wear	M
Thrusters 635, 655 or 660 are available	635 655 660
Thruster mounted right or left available	R L
Thickness of brake disc 12,5 mm, 25 mm, 30 mm or 40 mm	12 to 40

Example for ordering

Brake Caliper DH 035 PFM, thruster 660, thruster mounted right, thickness of brake disc 12,5 mm:

DH 035 PFM - 660 R - 12

Technical Data

Brake Caliper DH 035 PFM - 635

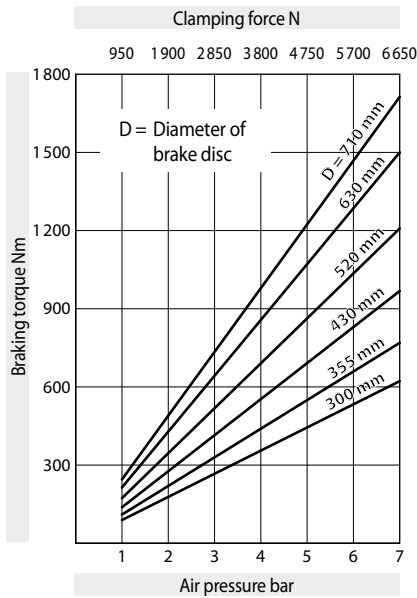

The braking torques shown in the diagram are based on a theoretical friction coefficient of 0,4.

Air pressure: max. 7 bar

Air volume: max. 175 cm³ per activation

Weight: 9,1 kg

Brake Caliper DH 035 PFM - 655

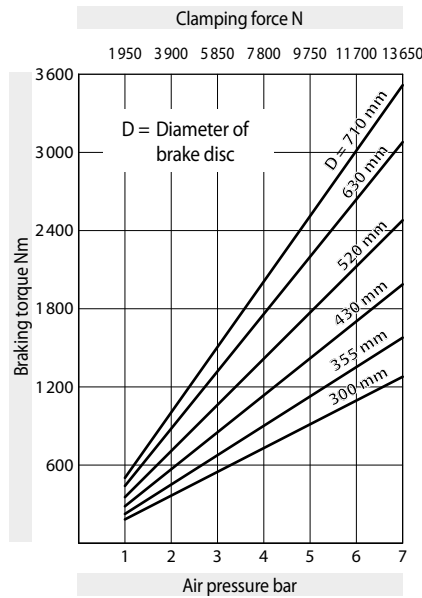

The braking torques shown in the diagram are based on a theoretical friction coefficient of 0,4.

Air pressure: max. 7 bar

Air volume: max. 740 cm³ per activation

Weight: 12,3 kg

Brake Caliper DH 035 PFM - 660

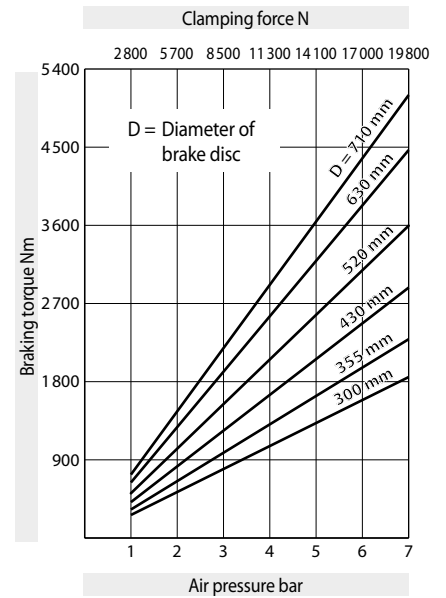

The braking torques shown in the diagram are based on a theoretical friction coefficient of 0,4.

Air pressure: max. 7 bar

Air volume: max. 450 cm³ per activation

Weight: 11,4 kg

Brake Caliper DH 035 PFM

pneumatically activated – spring released

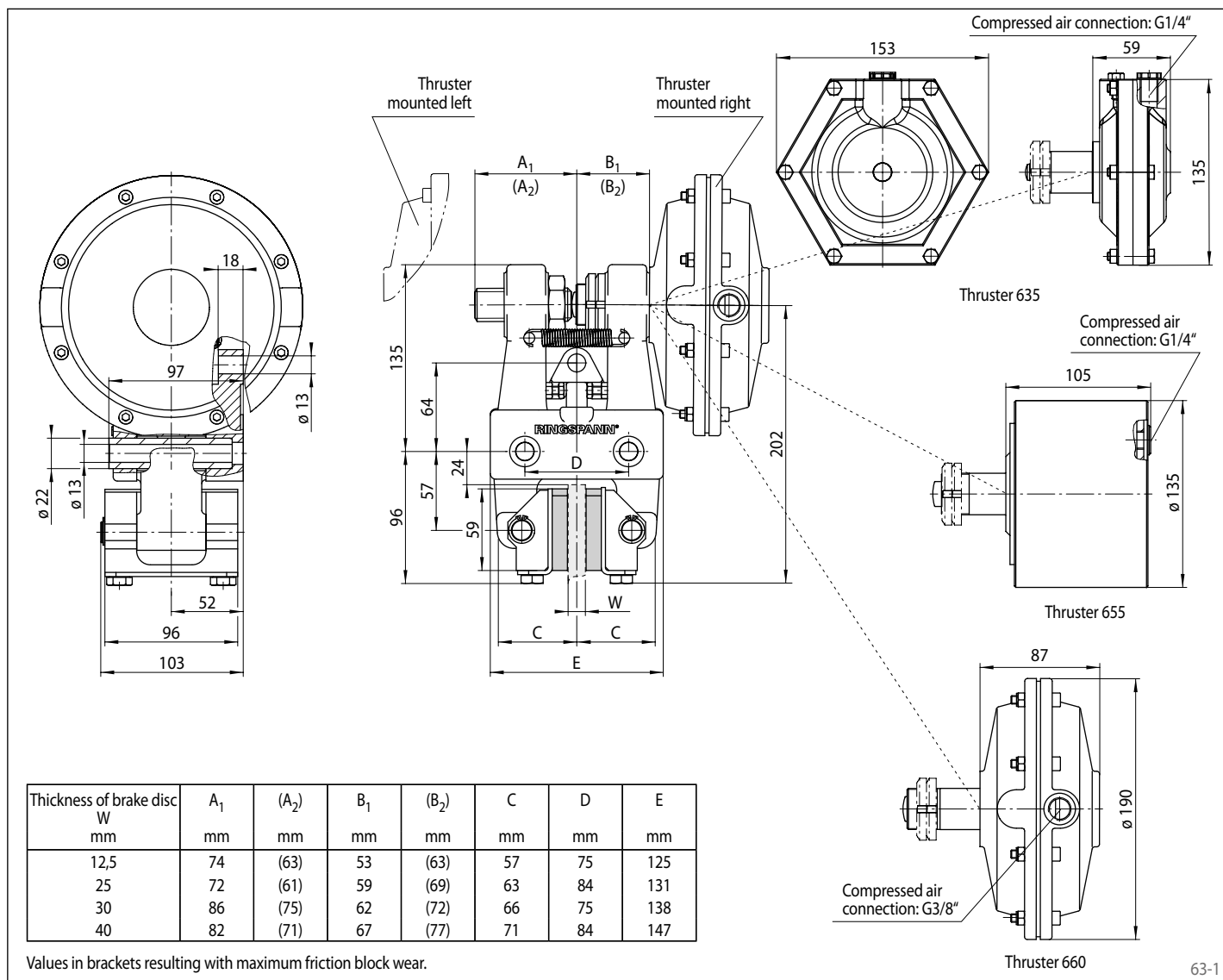

Brake Caliper DU 060 PFM

pneumatically activated – spring released

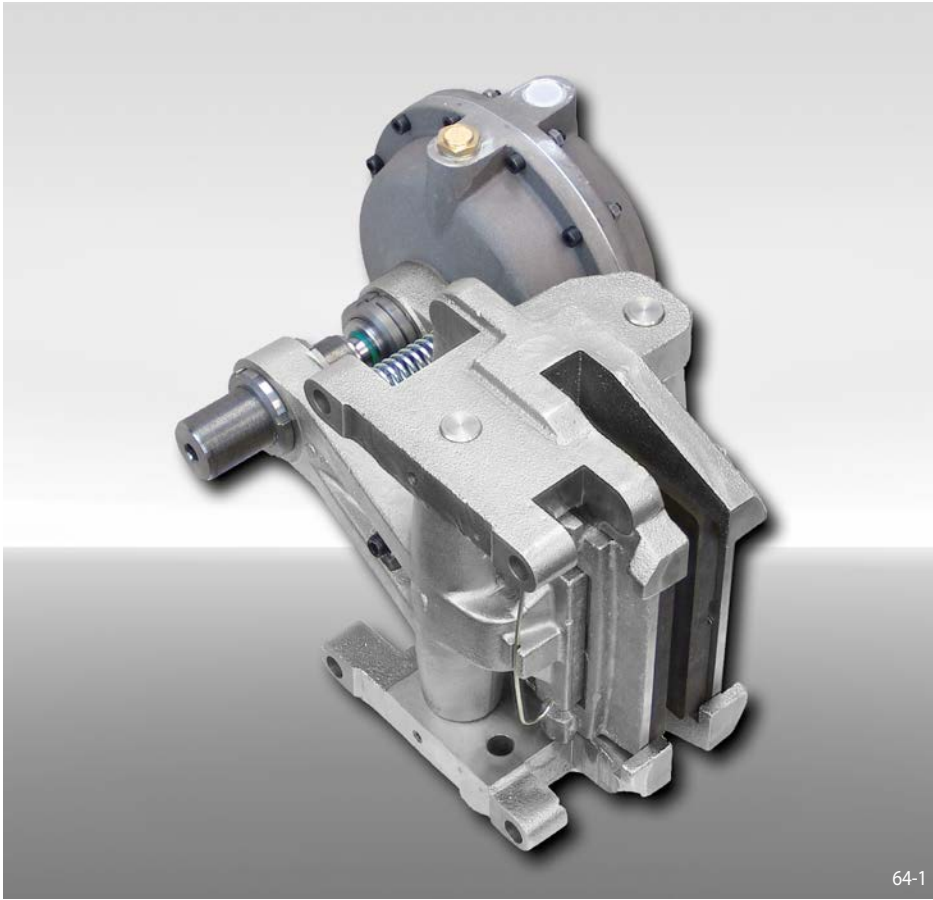

Features

Features	Code
Brake Caliper	D
Mounting to the machine, can be made either parallel or at the right angles to the brake disc	U
Frame size 060	060
Pneumatically activated	P
Spring released	F
Manual adjustment to accommodate friction block wear	M
Thrusters 660 or 680 are available	660 680
Thruster mounted right or left available	R L
Thickness of brake disc 25 mm or 40 mm	25 40

Example for ordering

Brake Caliper DU 060 PFM, thruster 680, thruster mounted right, thickness of brake disc 25 mm:

DU 060 PFM - 680 R - 25

Technical Data

Brake Caliper DU 060 PFM - 660

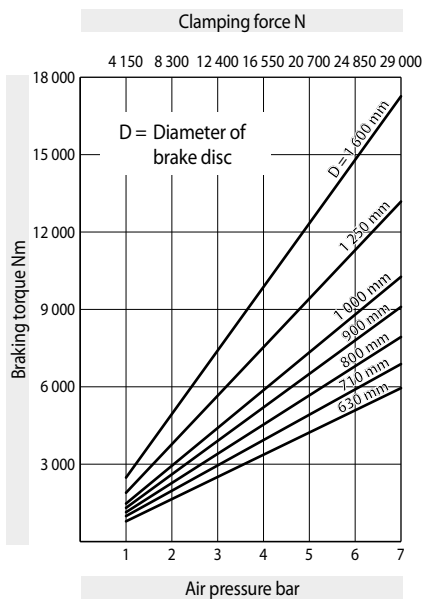

The braking torques shown in the diagram are based on a theoretical friction coefficient of 0,4.

Air pressure: max. 7 bar

Air volume: max. 450 cm³ per activation

Weight: 54 kg

Brake Caliper DU 060 PFM - 680

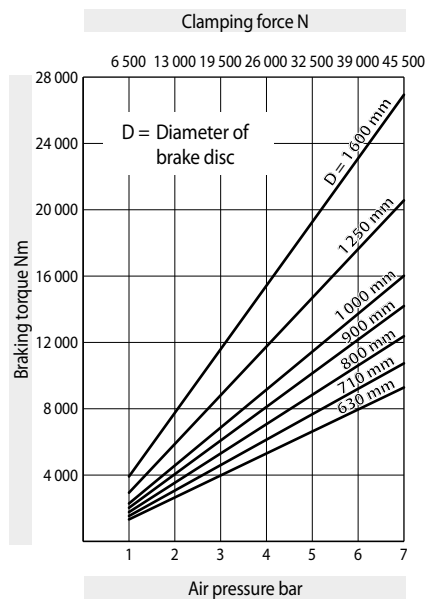

The braking torques shown in the diagram are based on a theoretical friction coefficient of 0,4.

Air pressure: max. 7 bar

Air volume: max. 2 000 cm³ per activation

Weight: 56 kg

Brake Caliper DU 060 PFM

pneumatically activated – spring released

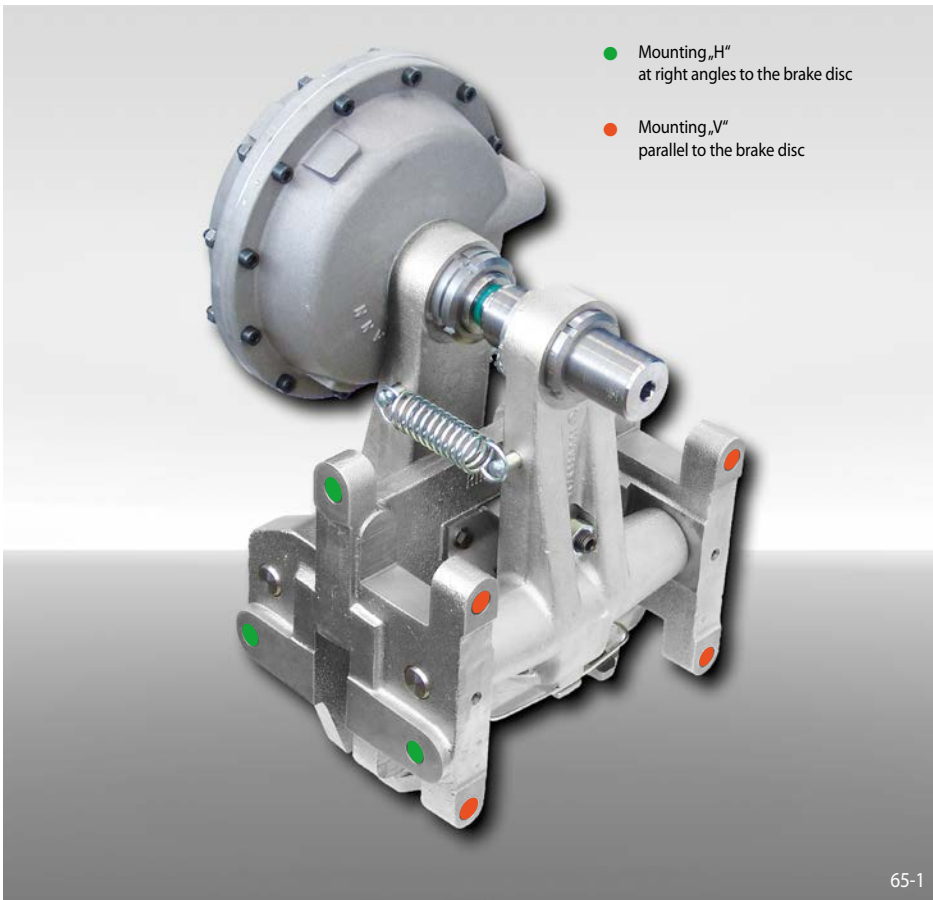

- Mounting „H“ at right angles to the brake disc
- Mounting „V“ parallel to the brake disc

65-1

Frame Design

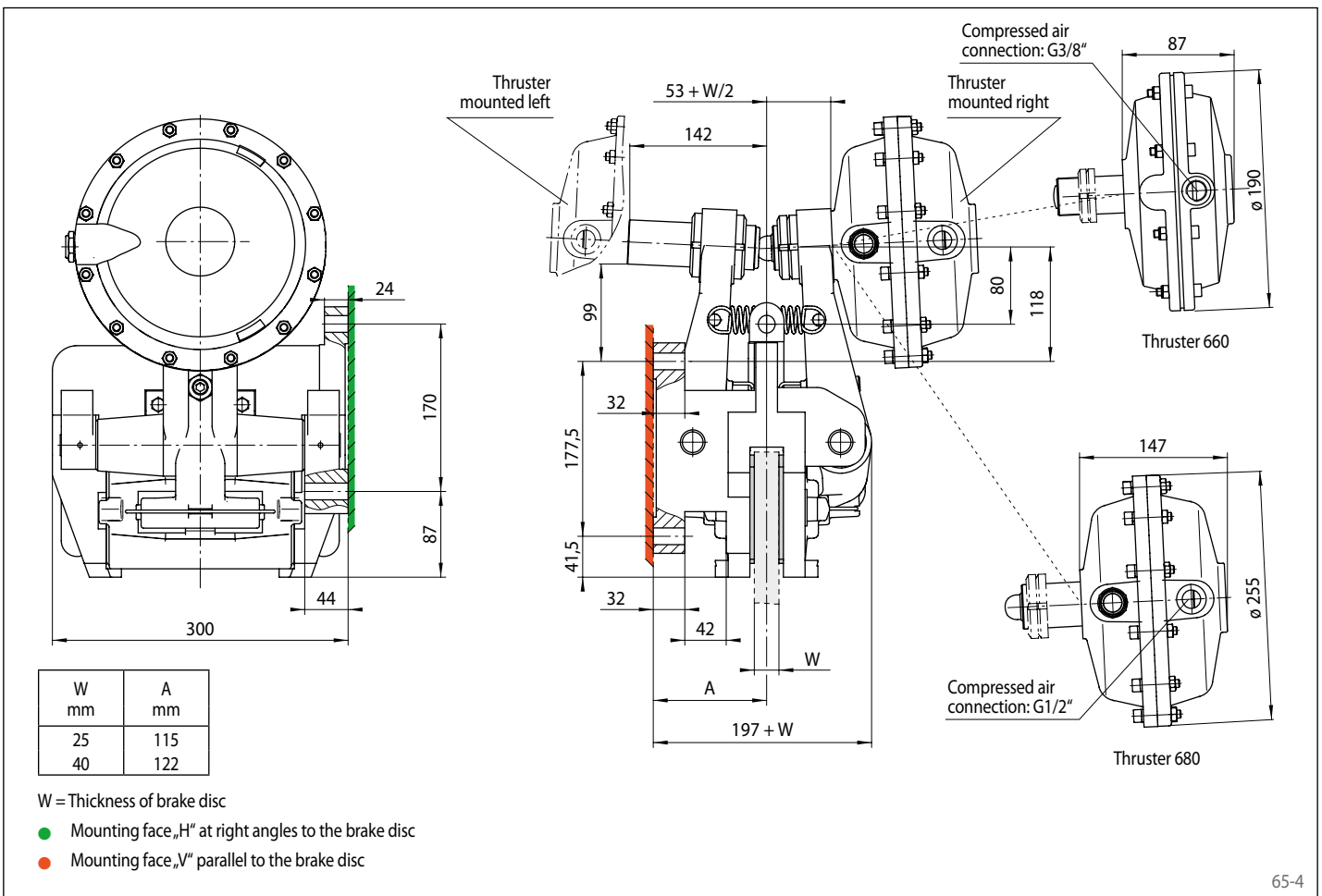
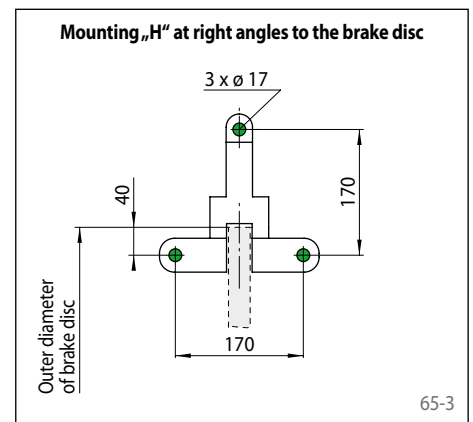
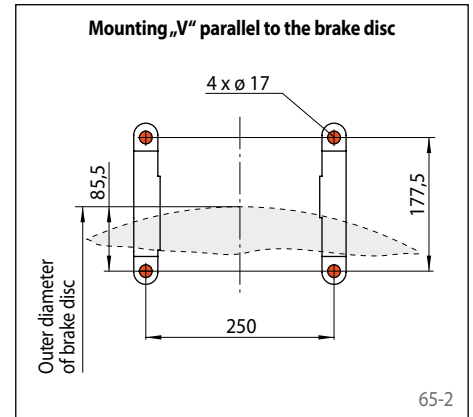

Brake Caliper DH 010 MSM

manually activated – manually released
with hand wheel

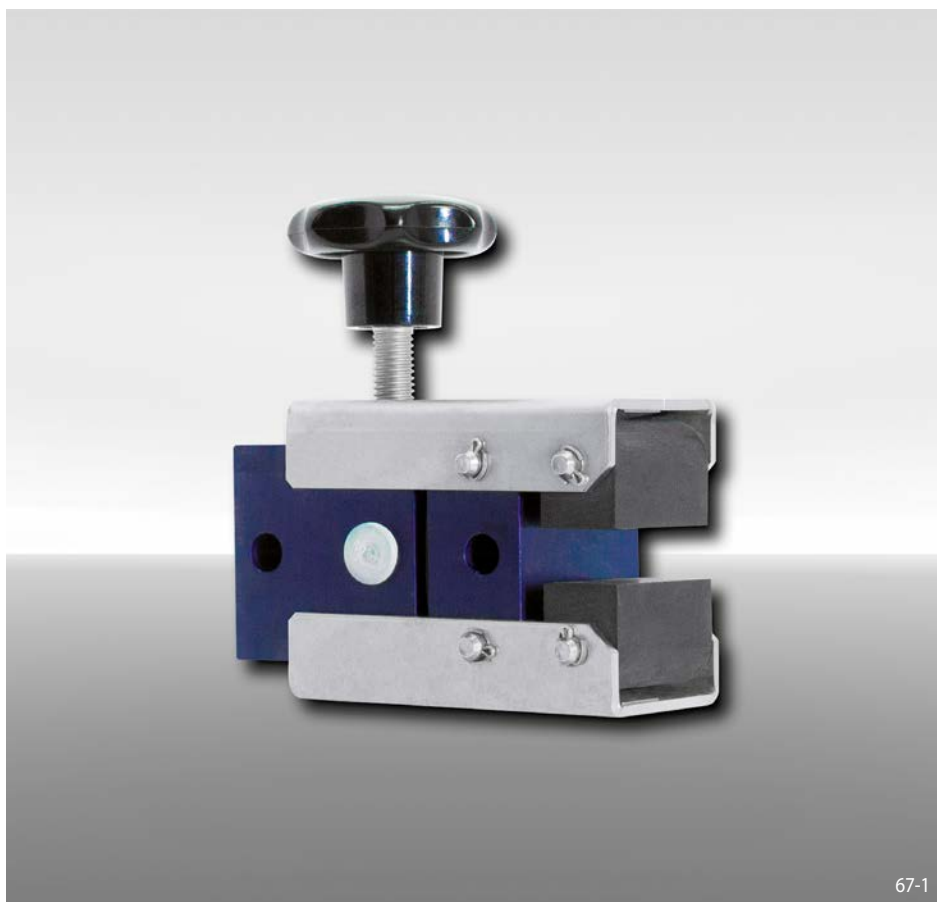

Features	Code
Brake Caliper	D
Mounting to the machine at right angles to the brake disc	H
Frame size 010	010
Manually activated	M
Manually released	S
Manual adjustment to accommodate friction block wear	M
Hand wheel 710	710
Hand wheel mounted right or left available	R L
Thickness of brake disc 12,5 mm	12

Example for ordering

Brake Caliper DH 010 MSM, hand wheel 710, hand wheel mounted right, thickness of brake disc 12,5 mm:

DH 010 MSM - 710 R - 12

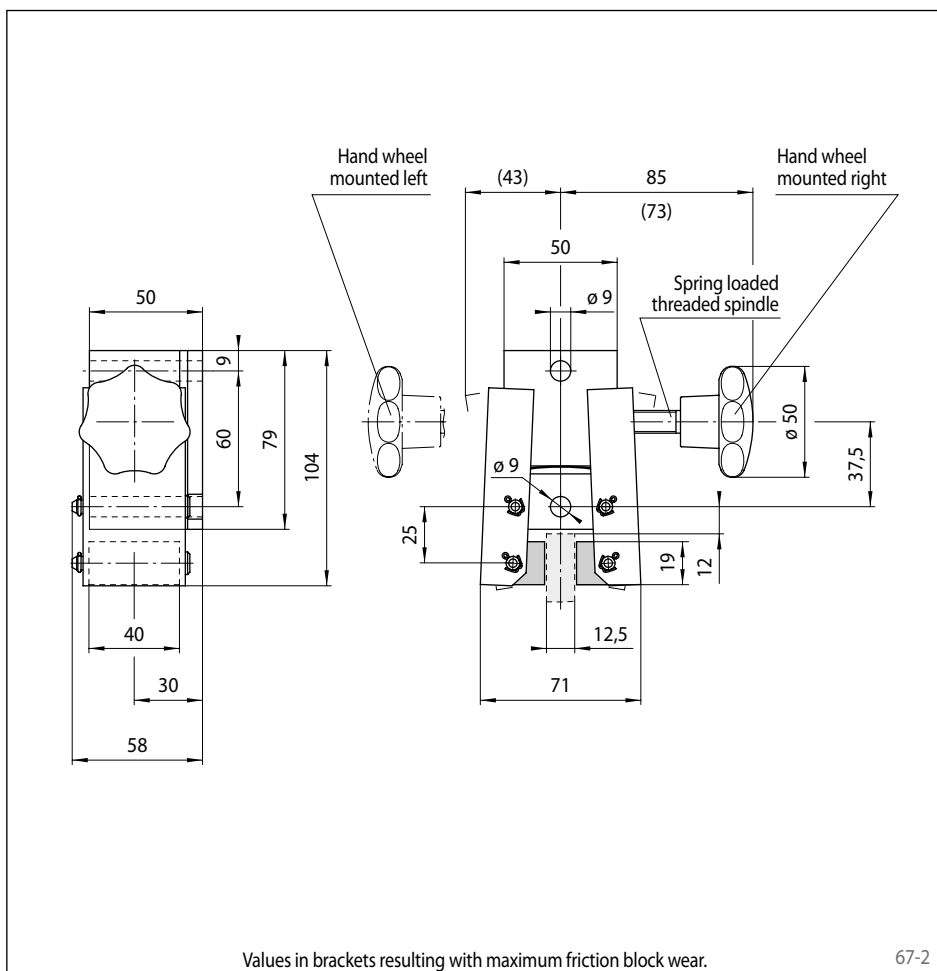

Values in brackets resulting with maximum friction block wear.

67-2

Technical Data

Brake Caliper DH 010 MSM with hand wheel 710	
Brake disc diameter	Braking torque
mm	Nm
125	20
150	30
200	40
250	50
300	60
355	75
Clamping force	576 N
Weight	1,1 kg

The braking torques shown in the diagram are based on a theoretical friction coefficient of 0,4. The maximum braking torques are based on an operating torque of 0,8 Nm at the hand wheel.

A spring loaded threaded spindle compensates for wear of the friction block during the braking action.

Brake Caliper DV 020 MSM

manually activated – manually released
with hand wheel



Features

Features	Code
Brake Caliper	D
Mounting to the machine parallel to the brake disc	V
Frame size 020	020
Manually activated	M
Manually released	S
Manual adjustment to accommodate friction block wear	M
Hand wheel 720	720
Hand wheel mounted right or left available	R L
Thickness of brake disc 12,5 mm	12

Example for ordering

Brake Caliper DV 020 MSM, hand wheel 720, hand wheel mounted right, thickness of brake disc 12,5 mm:

DV 020 MSM - 720 R - 12

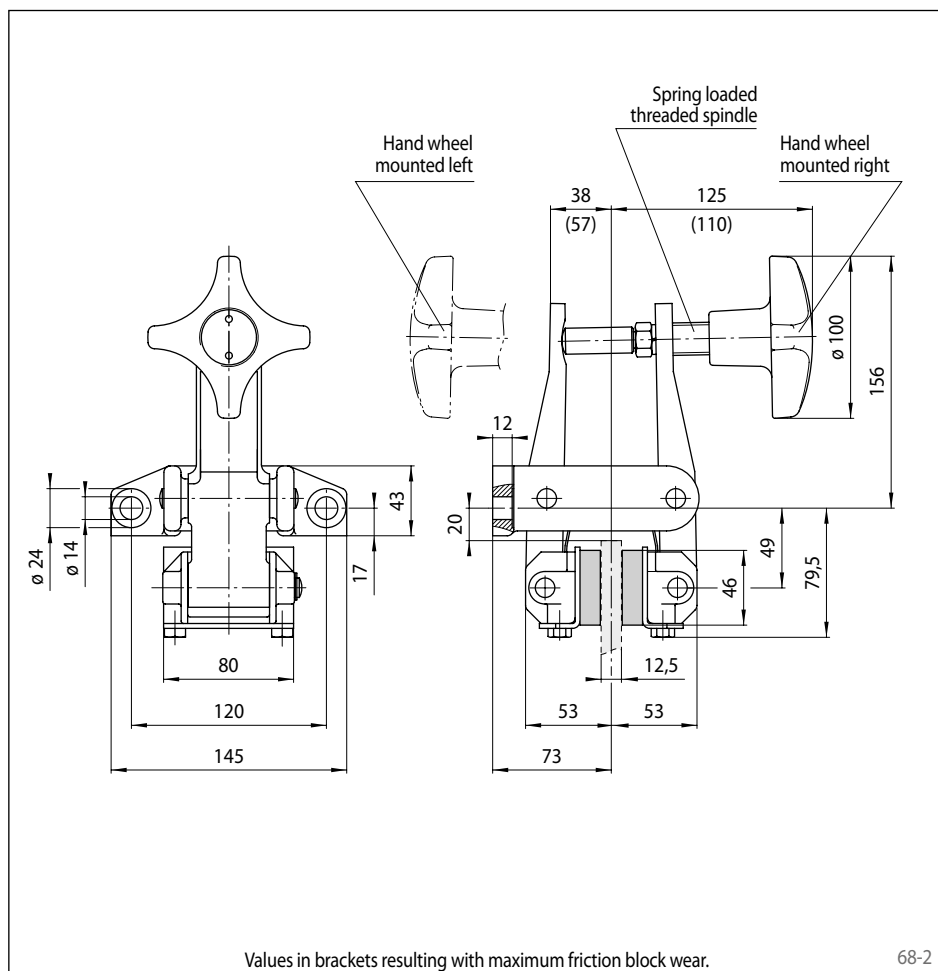

Technical Data

Brake Caliper DV 020 MSM with hand wheel 720	
Brake disc diameter	Braking torque
mm	Nm
200	160
250	215
300	270
355	335
430	420
520	520
Clamping force	2800 N
Weight	4,8 kg

The braking torques shown in the diagram are based on a theoretical friction coefficient of 0,4. The maximum braking torques are based on an operating torque of 7,7 Nm at the hand wheel.

A spring loaded threaded spindle compensates for wear of the friction block during the braking action.

Brake Caliper DH 020 MSM

manually activated – manually released
with hand wheel



69-1

Features

Features	Code
Brake Caliper	D
Mounting to the machine at right angles to the brake disc	H
Frame size 020	020
Manually activated	M
Manually released	S
Manual adjustment to accommodate friction block wear	M
Hand wheel 720	720
Position of the hand wheel to the right or left can be defined by turning the brake during installation	U
Thickness of brake disc 12,5 mm	12

Example for ordering

Brake Caliper DH 020 MSM, hand wheel 720, position of the hand wheel can be to the right or left, thickness of brake disc 12,5 mm:

DH 020 MSM - 720 U - 12

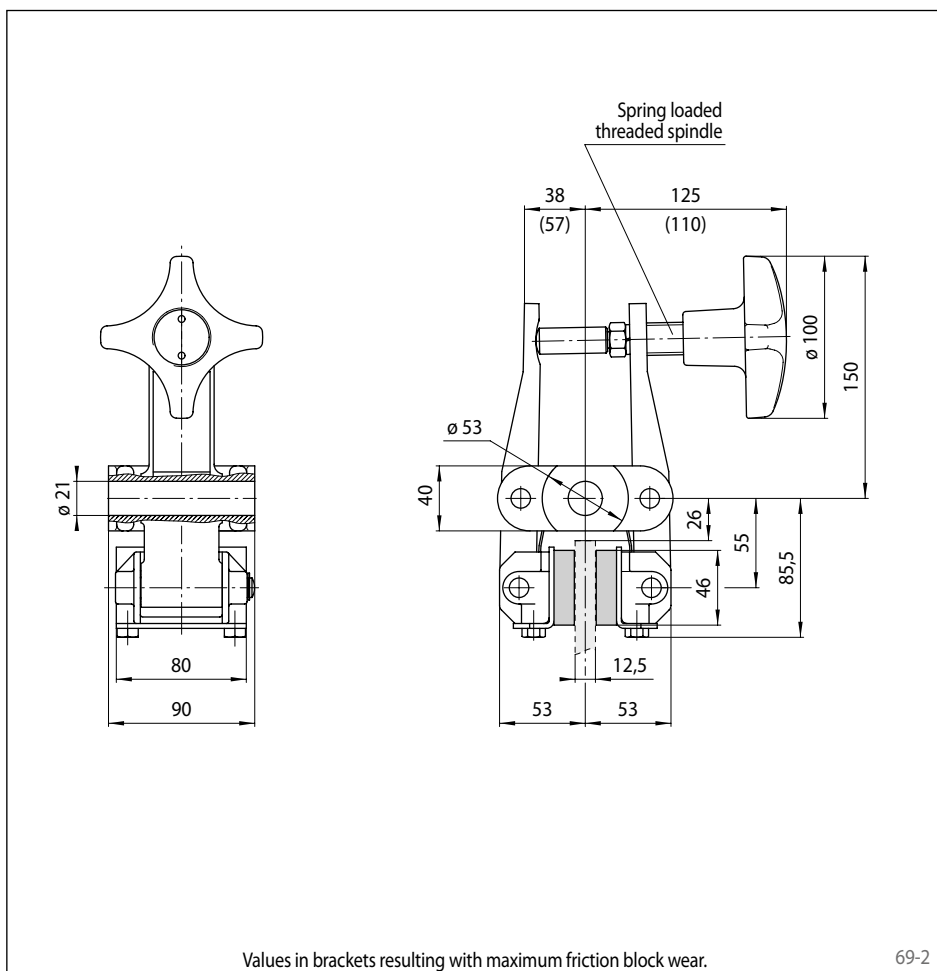

Technical Data

Brake Caliper DH 020 MSM with hand wheel 720	
Brake disc diameter	Braking torque
mm	Nm
200	160
250	215
300	270
355	335
430	420
520	520
Clamping force	2800 N
Weight	4,8 kg

The braking torques shown in the diagram are based on a theoretical friction coefficient of 0,4. The maximum braking torques are based on an operating torque of 7,7 Nm at the hand wheel.

A spring loaded threaded spindle compensates for wear of the friction block during the braking action.

Brake Caliper DV 020 MKM

manually activated – manually released
by Pull Cable

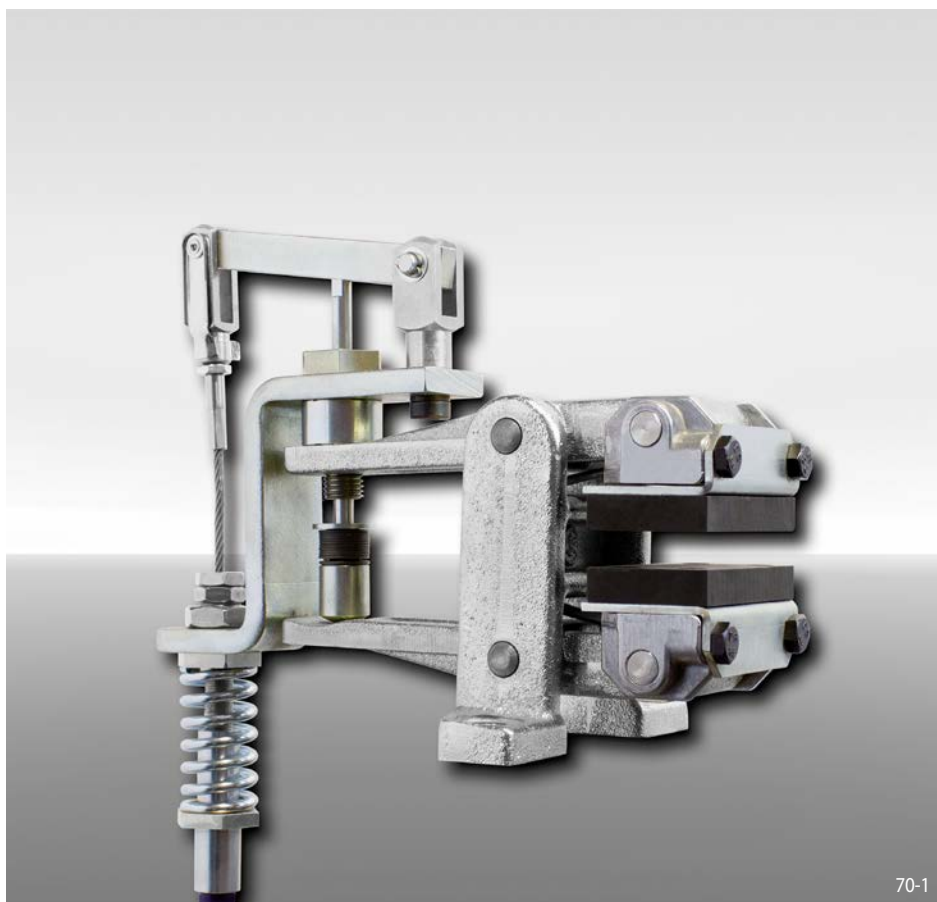

Features	Code
Brake Caliper	D
Mounting to the machine parallel to the brake disc	V
Frame size 020	020
Manually activated	M
Manually released	K
Manual adjustment to accommodate friction block wear	M
Spring-loaded pressure pin 730	730
Pull Cable installation mounted right or left available	R L
Thickness of brake disc 12,5 mm	12

Example for ordering

Brake Caliper DV 020 MKM, pressure pin 730, Pull Cable installation mounted right, thickness of brake disc 12,5 mm:

DV 020 MKM - 730 R - 12

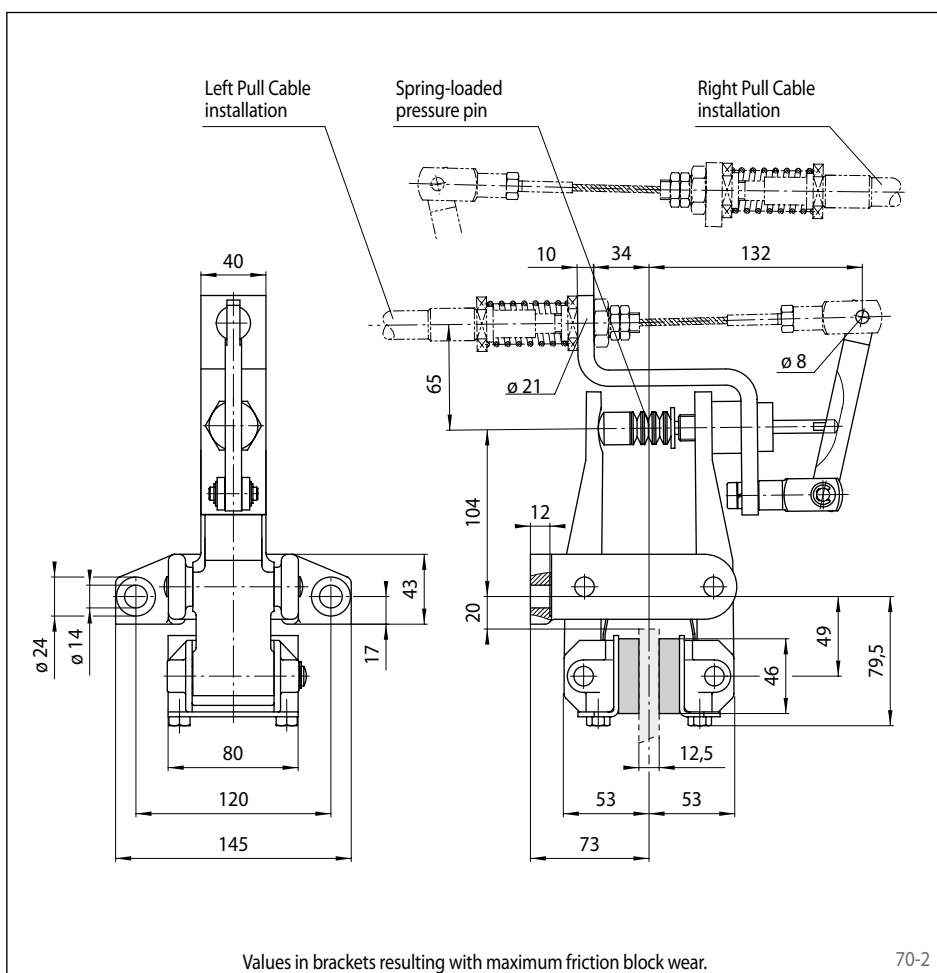

Technical Data

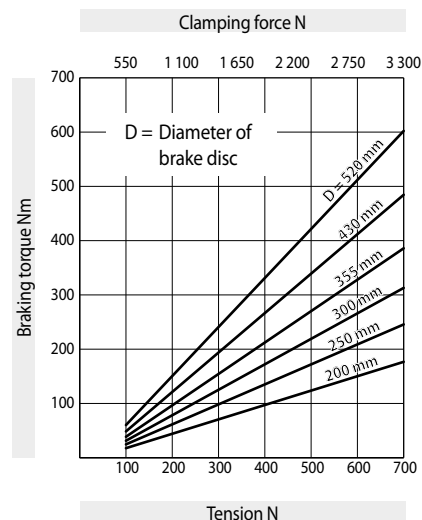

The braking torques shown in the diagram are based on a theoretical friction coefficient of 0,4.

Weight: 5,1 kg

Accessories

The Brake Caliper can be delivered fully assembled with RCS® Pull Cable and Hand Brake Lever. Please indicate the required cable length. For further information regarding RCS® Pull Cable and Hand Brake Lever see page 197. A spring loaded pressure pin compensates for wear of the friction block during the braking action.

Brake Caliper DH 020 MKM

manually activated – manually released
by Pull Cable

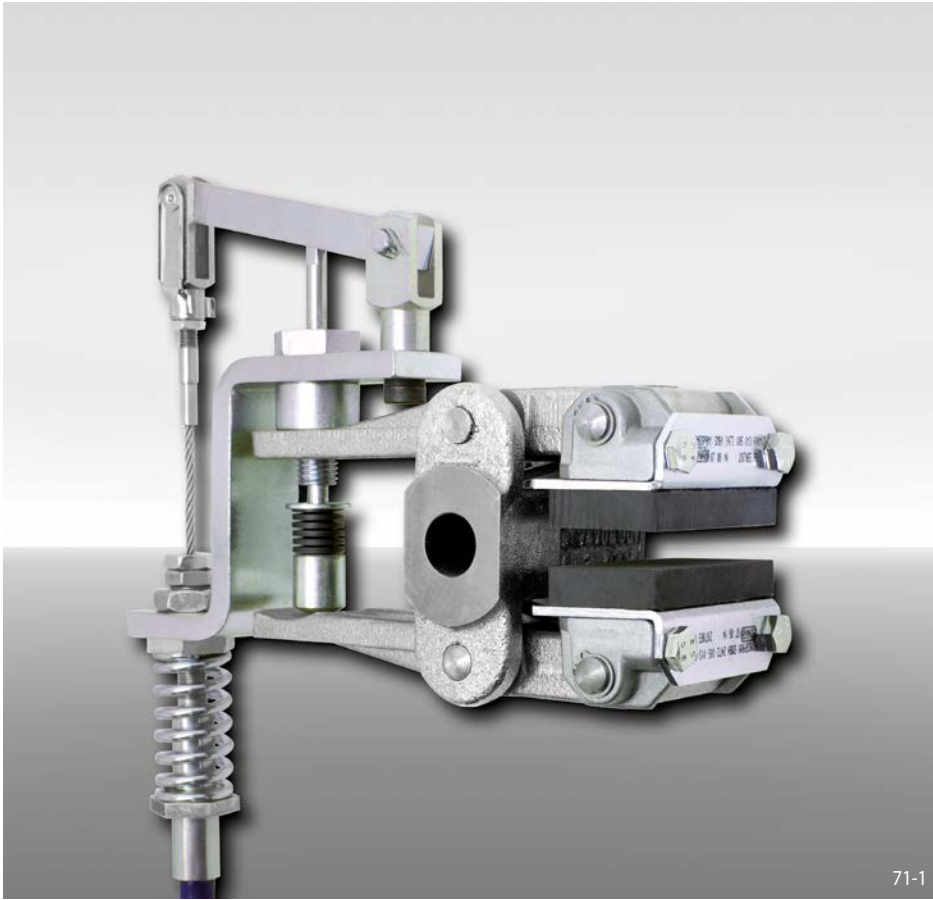

Features

Features	Code
Brake Caliper	D
Mounting to the machine at right angles to the brake disc	H
Frame size 020	020
Manually activated	M
Manually released	K
Manual adjustment to accommodate friction block wear	M
Spring-loaded pressure pin 730	730
Position of the Pull Cable installation to the right or left can be defined by turning the brake during installation	U
Thickness of brake disc 12,5 mm	12

Example for ordering

Brake Caliper DH 020 MKM, pressure pin 730, position of the Pull Cable installation can be to the right or left, thickness of brake disc 12,5 mm:

DH 020 MKM - 730 U - 12

Technical Data

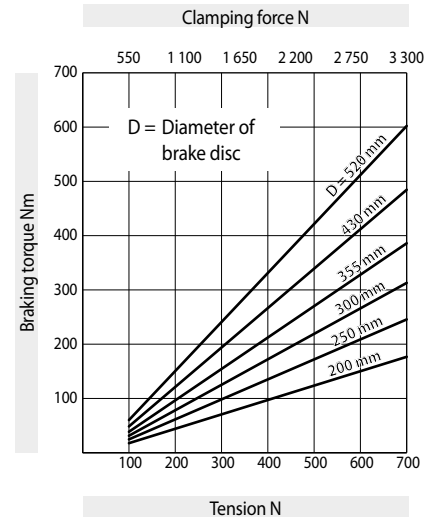

The braking torques shown in the diagram are based on a theoretical friction coefficient of 0,4.

Weight: 5,1 kg

Accessories

The Brake Caliper can be delivered fully assembled with RCS® Pull Cable and Hand Brake Lever. Please indicate the required cable length. For further information regarding RCS® Pull Cable and Hand Brake Lever see page 197.

A spring loaded pressure pin compensates for wear of the friction block during the braking action.

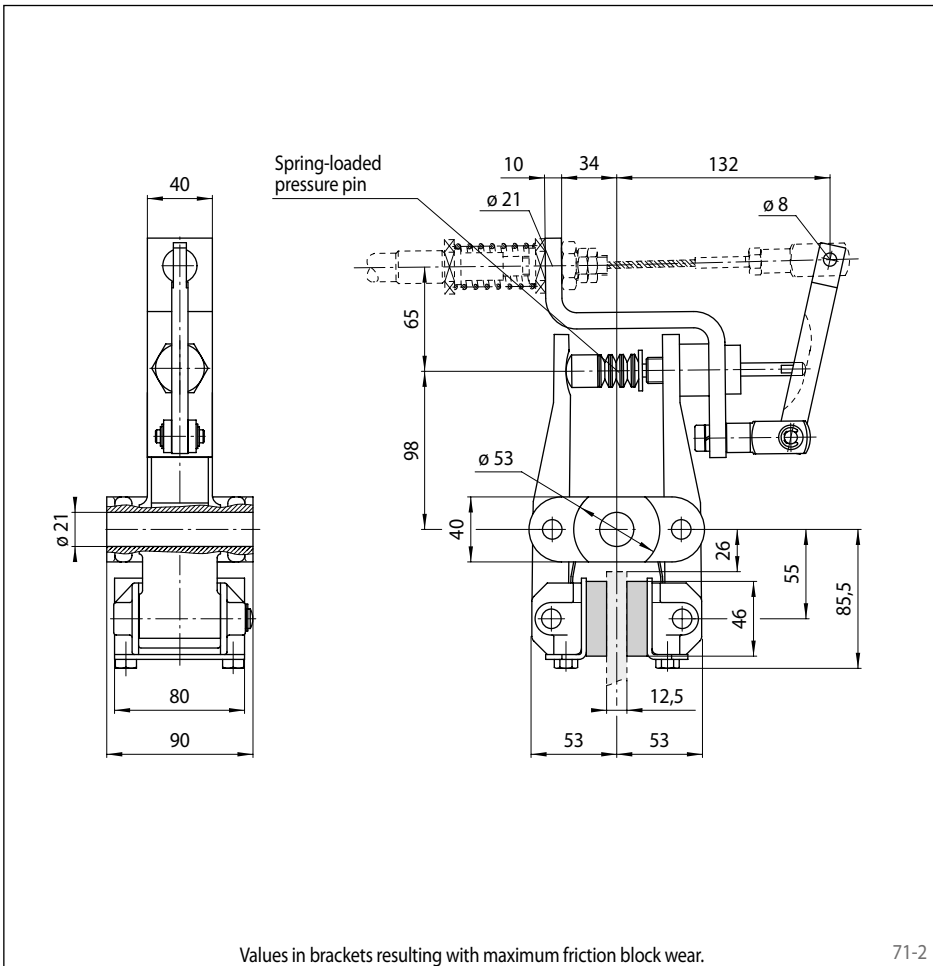

Brake Caliper DH 012 FEM

spring activated – electromagnetically released



Figure shows product with inductive proximity switch: "Brake released"

72-1

Features

Features	Code
Brake Caliper	D
Mounting to the machine at right angles to the brake disc	H
Frame size 012	012
Spring activated	F
Electromagnetically released	E
Manual adjustment to accommodate friction block wear	M
Electromagnet for 110/120 VAC	440
Electromagnet for 230/240 VAC	450
Electromagnet mounted right or left available	R L
Thickness of brake disc 12,5 mm	12

Example for ordering

Brake Caliper DH 012 FEM, electromagnet for 110 V, electromagnet mounted right, thickness of brake disc 12,5 mm:

DH 012 FEM - 440 R - 12

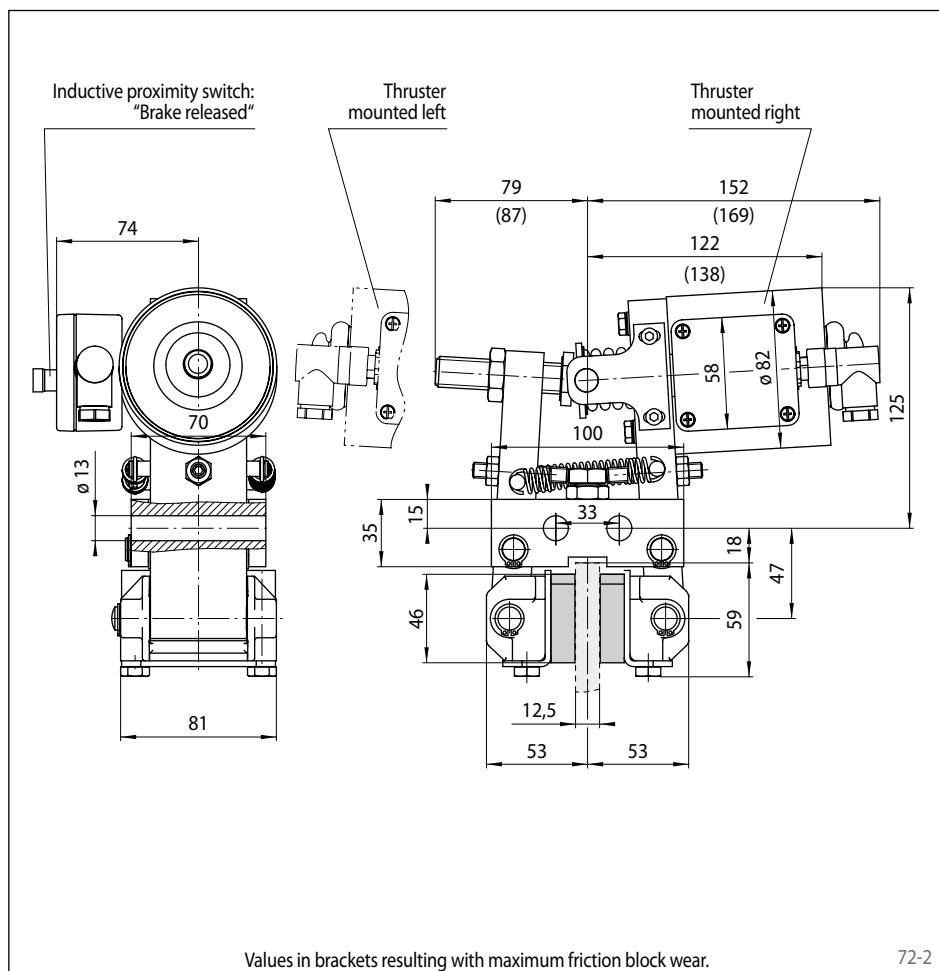

Values in brackets resulting with maximum friction block wear.

72-2

Technical Data

	Brake Caliper DH 012 FEM	
	with electro-magnet 440 for 110/120 V	with electro-magnet 450 for 230/240 V
Brake disc diameter	Braking torque	
mm	Nm	
200	110	
250	140	
300	180	
355	220	
430	280	
520	340	
Clamping force	1850 N	
Power consumption in open position	10 W (100% duty factor)	
Fuse rating	6A	
Max. number of actuation	600/h permanent activations at 20° C ambient temperature	
Weight	7 kg	

The braking torques shown in the diagram are based on a theoretical friction coefficient of 0,4.

Accessories

Universal Transformer see page 196.

Options

- Available with cCSAus approval
- Inductive proximity switch: "Brake released"

Brake Caliper DV 020 FEM

spring activated – electromagnetically released



Figure shows product with inductive proximity switch: "Brake released"

73-1

Features

Features	Code
Brake Caliper	D
Mounting to the machine parallel to the brake disc	V
Frame size 020	020
Spring activated	F
Electromagnetically released	E
Manual adjustment to accommodate friction block wear	M
Electromagnet for 230/240 VAC	460
Electromagnet mounted right or left available	R L
Thickness of brake disc 12,5 mm	12

Example for ordering

Brake Caliper DV 020 FEM, electromagnet for 230 V, electromagnet mounted right, thickness of brake disc 12,5 mm:

DV 020 FEM - 460 R - 12

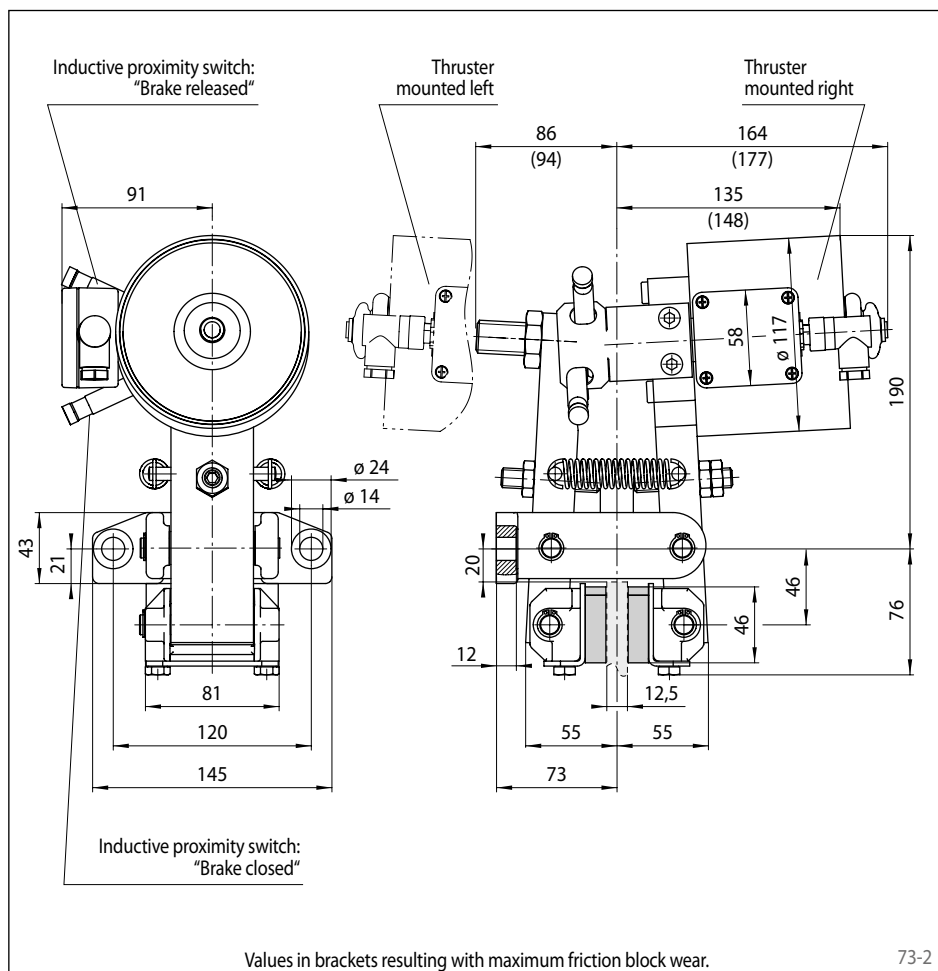

Values in brackets resulting with maximum friction block wear.

73-2

Technical Data

Brake Caliper DV 020 FEM with electromagnet 460 for 230/240 V	
Brake disc diameter	Braking torque
mm	Nm
200	190
250	260
300	330
355	400
430	510
520	630
Clamping force	3400 N
Power consumption in open position	12 W (100% duty factor)
Fuse rating	6A
Max. number of actuation	800/h permanent activations at 20° C ambient temperature
Weight	15 kg

The braking torques shown in the diagram are based on a theoretical friction coefficient of 0,4.

Accessories

Universal Transformer see page 196.

Options

- Available with cCSAus approval
- Inductive proximity switch: "Brake released"
- Inductive proximity switch: "Brake closed"

Brake Calipers EV 018 FEM and EH 018 FEM

spring activated – electromagnetically released

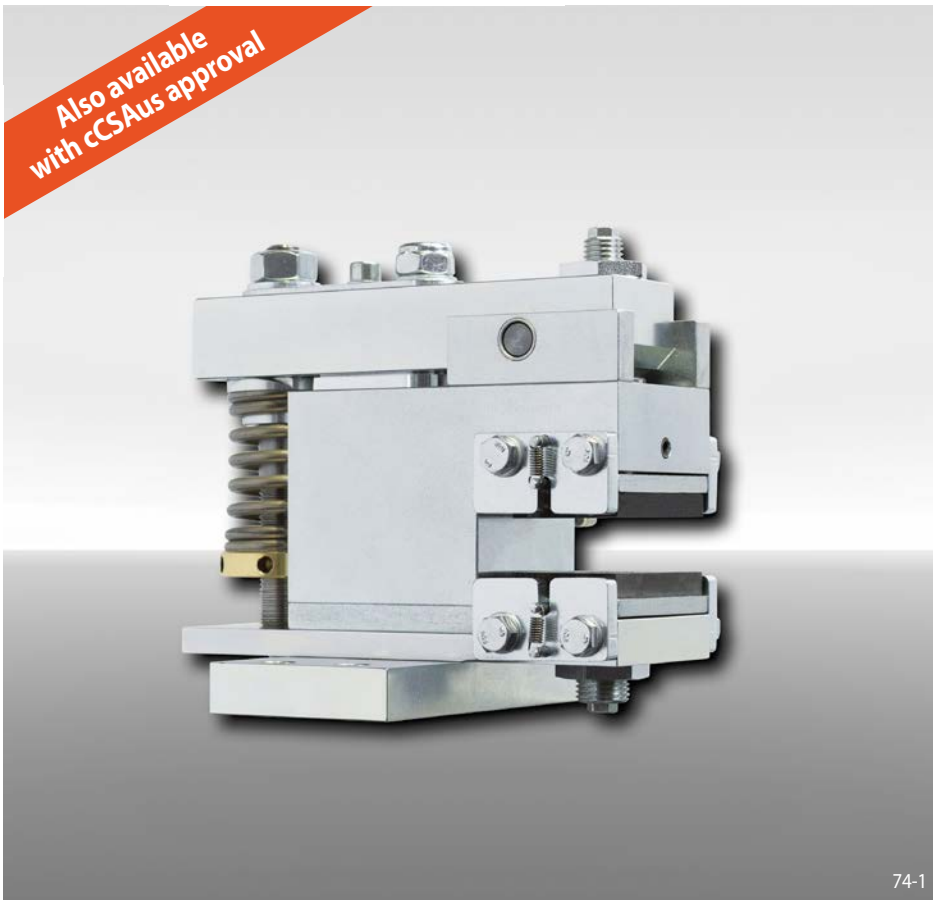

74-1

Advantages

The brake caliper EV 018 FEM or EH 018 FEM is a very compact and high efficient disc brake with very low power consumption. Its floating bearing compensates small misalignments of the brake disc. The separate electronic module (included) reduces the power consumption in open position automatically.

Options

- Available with cCSAus approval
- Inductive proximity switch: "Brake released"-, "Brake closed"-status and/or "Friction block wear adjustment necessary"

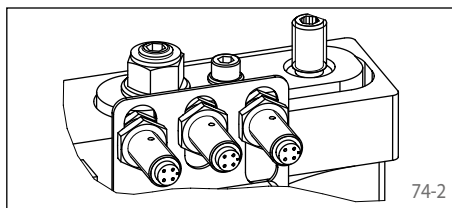

74-2

Electronic module

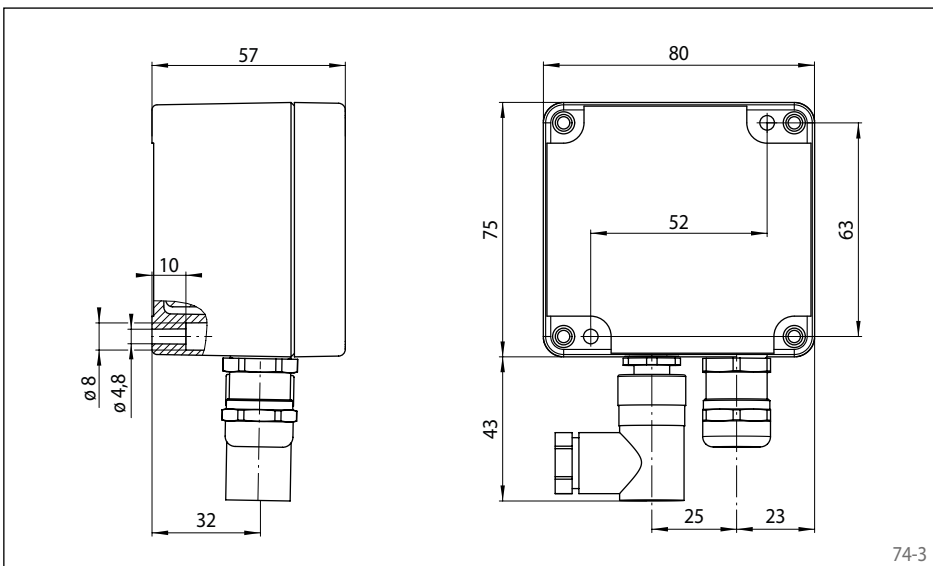

74-3

Features

Features	Code
Brake Caliper with electromagnet	E
Mounting to the machine parallel or at right angles to the brake disc	V H
Frame size 018	018
Spring activated	F
Electromagnetically released	E
Manual adjustment to accommodate friction block wear	M
Supply voltage 220 to 240 VAC	240
Supply voltage 380 to 480 VAC	480
Electromagnet mounted in central position	M
Thickness of brake disc 8 ... 15 mm	12
or 16 ... 20 mm	20

Example for ordering

Brake Caliper EV 018 FEM, supply voltage 400 VAC, electromagnet mounted in central position, thickness of brake disc 15 mm:

EV 018 FEM - 480 M - 12

Technical Data

Brake disc diameter mm	Brake Calipers EV 018 FEM and EH 018 FEM with supply voltage	
	220 to 240 VAC	380 to 480 VAC
125	100	100
150	130	130
200	200	200
250	260	260
300	320	320
355	400	400
Clamping force	3200 N	
Clamping force or braking torque adjustable	50 - 100%	
Power consumption in open position	24 W	32 W (100% duty factor)
Power when opening the brake (< 1 s)	800 W	1200 W
Fuse rating	10 A, Type "B"	
Max. number of actuation	360/h permanent activations at 20° C ambient temperature	
Actuation frequency*	at least 8 seconds between 2 activations	
Weight	6,5 kg	

The braking torques shown in the diagram are based on a theoretical friction coefficient of 0,4.

* Shorter actuation frequency on request

Brake Calipers EV 018 FEM and EH 018 FEM

spring activated – electromagnetically released

Brake Caliper EV 018 FEM

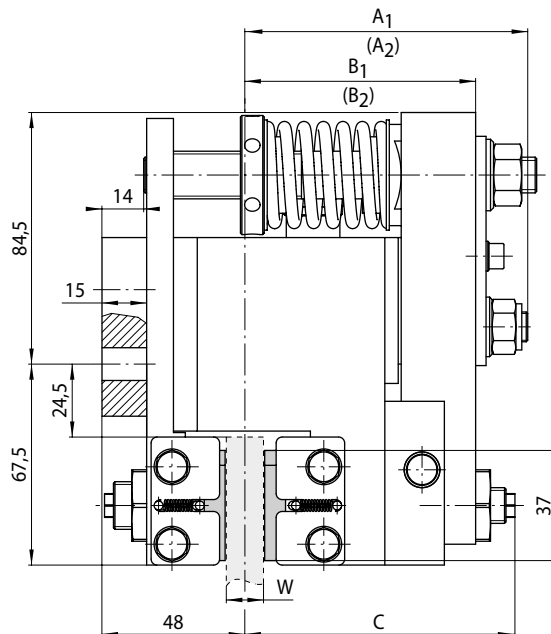
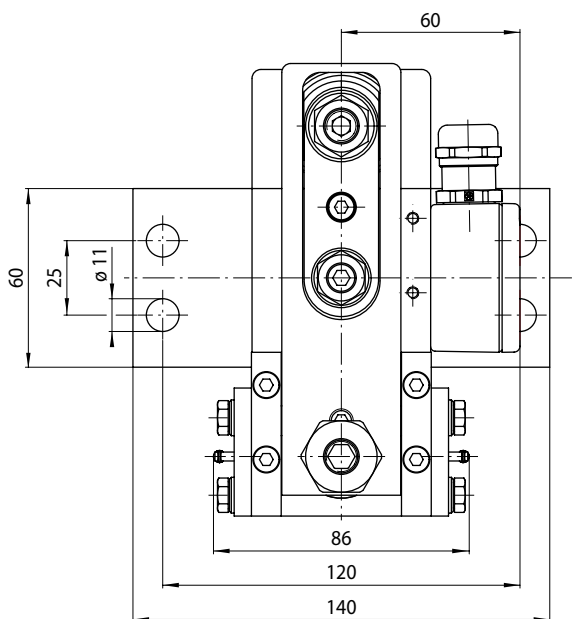

Thickness of brake disc W mm	A ₁ mm	(A ₂) mm	B ₁ mm	(B ₂) mm	C mm
8 ... 15	97	(108)	76,5	(95)	90
16 ... 20	99	(110)	78,5	(97)	94

Values in brackets resulting with friction block wear.

75-1

Brake Caliper EH 018 FEM

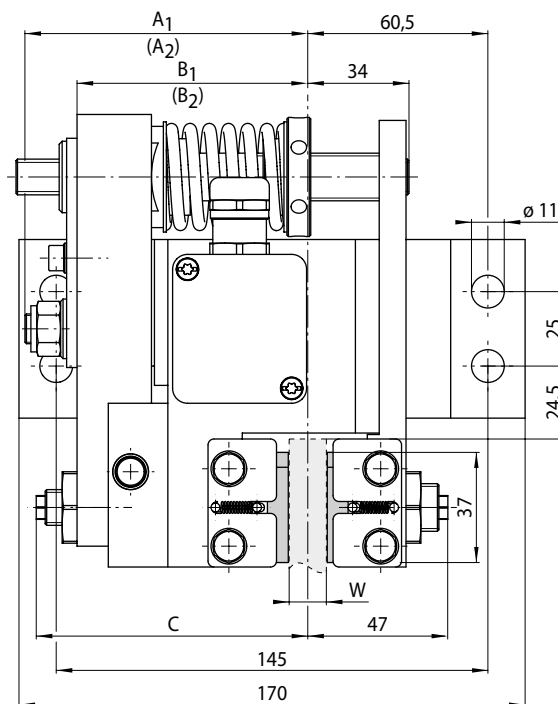
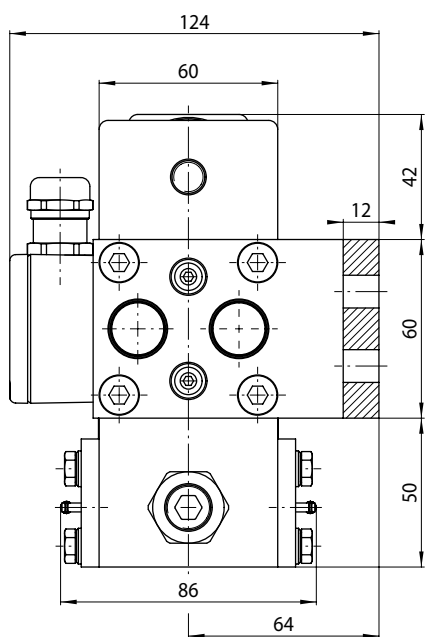

Thickness of brake disc W mm	A ₁ mm	(A ₂) mm	B ₁ mm	(B ₂) mm	C mm
8 ... 15	97	(108)	76,5	(95)	90
16 ... 20	99	(110)	78,5	(97)	94

Values in brackets resulting with friction block wear.

75-2

Brake Calipers EV 024 FEM and EH 024 FEM

spring activated – electromagnetically released



Features	Code
Brake Caliper with electromagnet	E
Mounting to the machine parallel or at right angles to the brake disc	V H
Frame size 024	024
Spring activated	F
Electromagnetically released	E
Manual adjustment to accommodate friction block wear	M
Supply voltage 220 to 240 VAC	240
Supply voltage 380 to 480 VAC	480
Electromagnet mounted in central position	M
Thickness of brake disc 10 ... 16 mm	12
or 18 ... 26 mm	25

Example for ordering

Brake Caliper EV 024 FEM, supply voltage 400 VAC, electromagnet mounted in central position, thickness of brake disc 15 mm:

EV 024 FEM - 480 M - 12

Advantages

The brake caliper EV 024 FEM or EH 024 FEM is a very compact and high efficient disc brake with very low power consumption. Its floating bearing compensates small misalignments of the brake disc. The attached electronic reduces the power consumption in open position automatically.

Options

- Available with cCSAus approval
- Inductive proximity switch: "Brake released"-, "Brake closed"-status and/or "Friction block wear adjustment necessary"

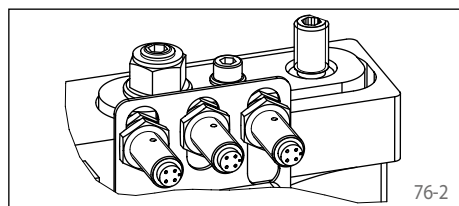

Technical Data

	Brake Calipers EV 024 FEM and EH 024 FEM with supply voltage	
	220 to 240 VAC	380 to 480 VAC
Brake disc diameter	Braking torque	Braking torque
mm	Nm	Nm
250	400	
300	500	
355	610	
430	760	
520	940	
630	1 160	
Clamping force	5 000 N	
Clamping force or braking torque adjustable	50 - 100%	
Power consumption in open position	20 W	20 W
	(100% duty factor)	
Power when opening the brake (< 1 s)	2 850 W	1 800 W
Fuse rating	10 A, Type "B"	
Max. number of actuation	360/h permanent activations at 20° C ambient temperature	
Actuation frequency*	at least 8 seconds between 2 activations	
Weight	13 kg	

The braking torques shown in the diagram are based on a theoretical friction coefficient of 0,4.

* Shorter actuation frequency on request

Brake Calipers EV 024 FEM and EH 024 FEM

spring activated – electromagnetically released

Brake Caliper EV 024 FEM

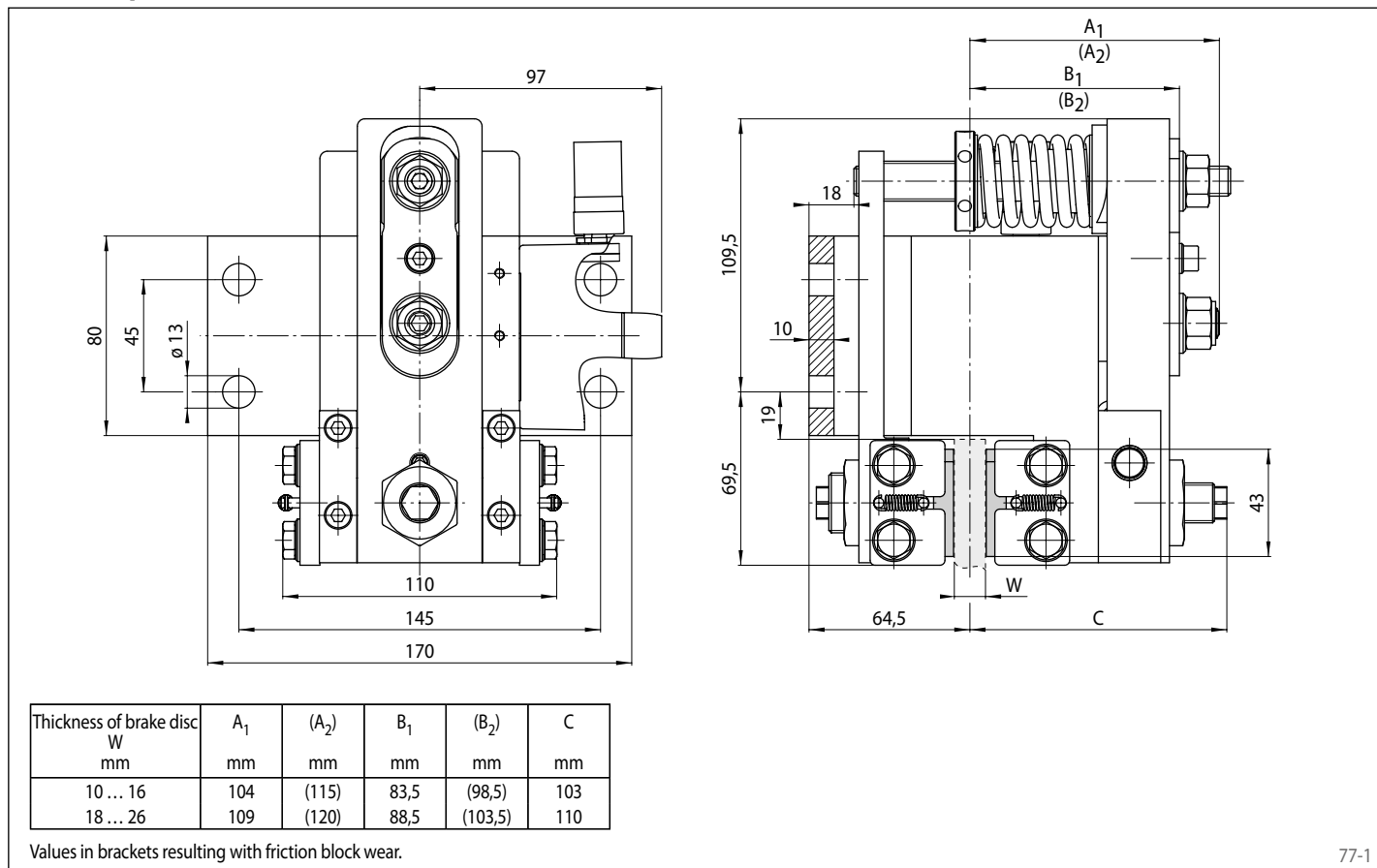

77-1

Brake Caliper EH 024 FEM

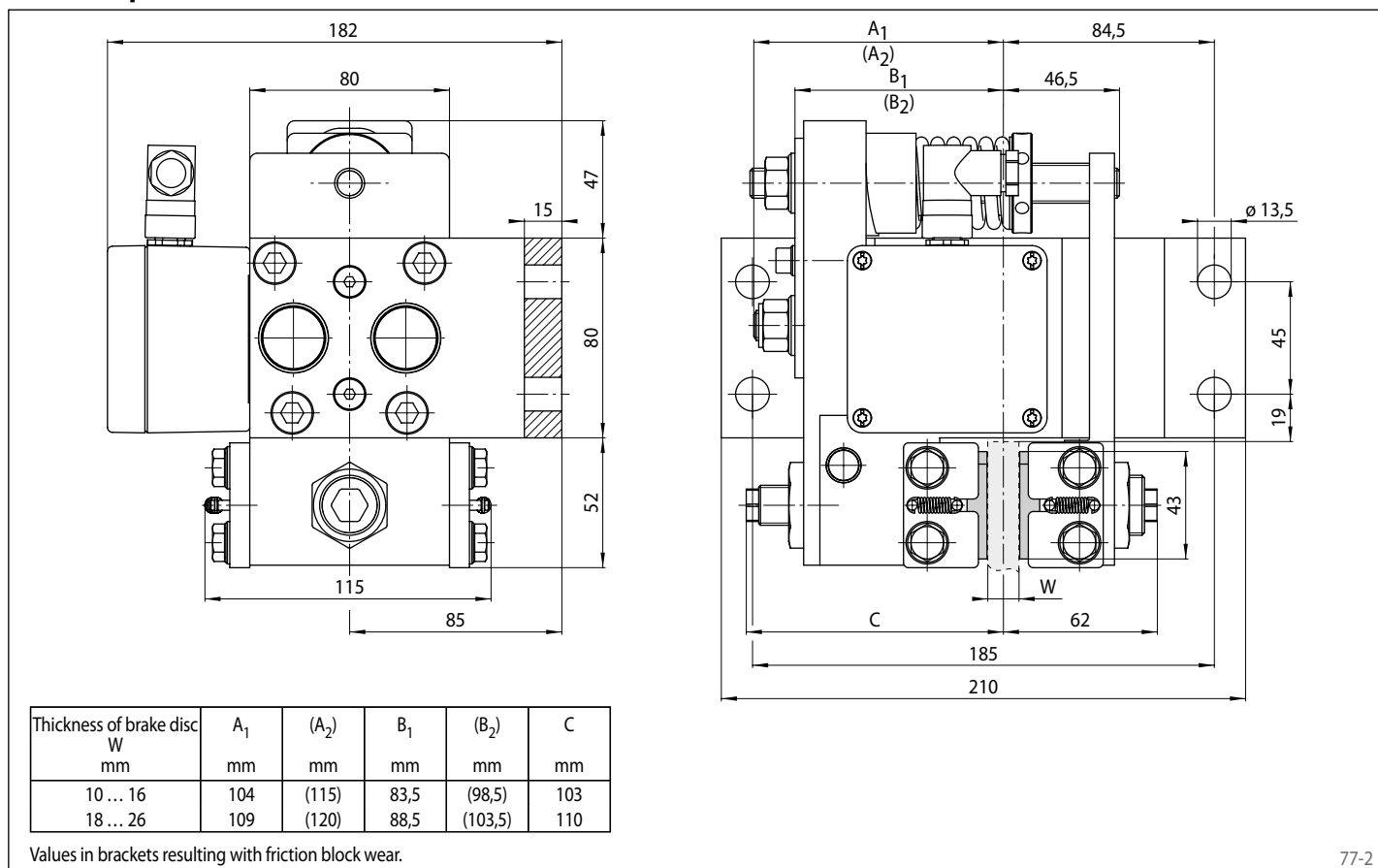

77-2

Brake Calipers EV 028 FEM and EH 028 FEM

spring activated – electromagnetically released



Features	Code
Brake Caliper with electromagnet	E
Mounting to the machine parallel or at right angles to the brake disc	V H
Frame size 028	028
Spring activated	F
Electromagnetically released	E
Manual adjustment to accommodate friction block wear	M
Supply voltage 220 to 240 VAC	240
Supply voltage 380 to 480 VAC	480
Electromagnet mounted in central position	M
Thickness of brake disc 10 ... 16 mm	12
or 18 ... 26 mm	25

Example for ordering

Brake Caliper EV 028 FEM, supply voltage 400 VAC, Electromagnet mounted in central position, thickness of brake disc 15 mm:

EV 028 FEM - 480 M - 12

Advantages

The brake caliper EV 028 FEM or EH 028 FEM is a very compact and high efficient disc brake with very low power consumption. Its floating bearing compensates small misalignments of the brake disc. The attached electronic reduces the power consumption in open position automatically.

Options

- Available with cCSAus approval
- Inductive proximity switch: "Brake released"-, "Brake closed"-status and/or "Friction block wear adjustment necessary"

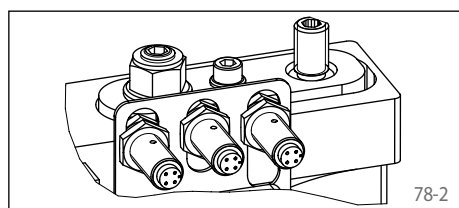

Technical Data

	Brake Calipers EV 028 FEM and EH 028 FEM with supply voltage	
	220 to 240 VAC	380 to 480 VAC
Brake disc diameter	Braking torque	Braking torque
mm	Nm	Nm
300	940	
355	1 160	
430	1 460	
520	1 820	
630	2 260	
710	2 580	
Clamping force	10 000 N	
Clamping force or braking torque adjustable	60 - 100%	
Power consumption in open position	15 W	19 W
	(100% duty factor)	
Power when opening the brake (< 1 s)	1 850 W	2 500 W
Fuse rating	10 A, Type "B"	
Max. number of actuation	360/h permanent activations at 20° C ambient temperature	
Actuation frequency*	at least 8 seconds between 2 activations	
Weight	24 kg	

The braking torques shown in the diagram are based on a theoretical friction coefficient of 0,4.

* Shorter actuation frequency on request

Brake Calipers EV 028 FEM and EH 028 FEM

spring activated – electromagnetically released

Brake Caliper EV 028 FEM

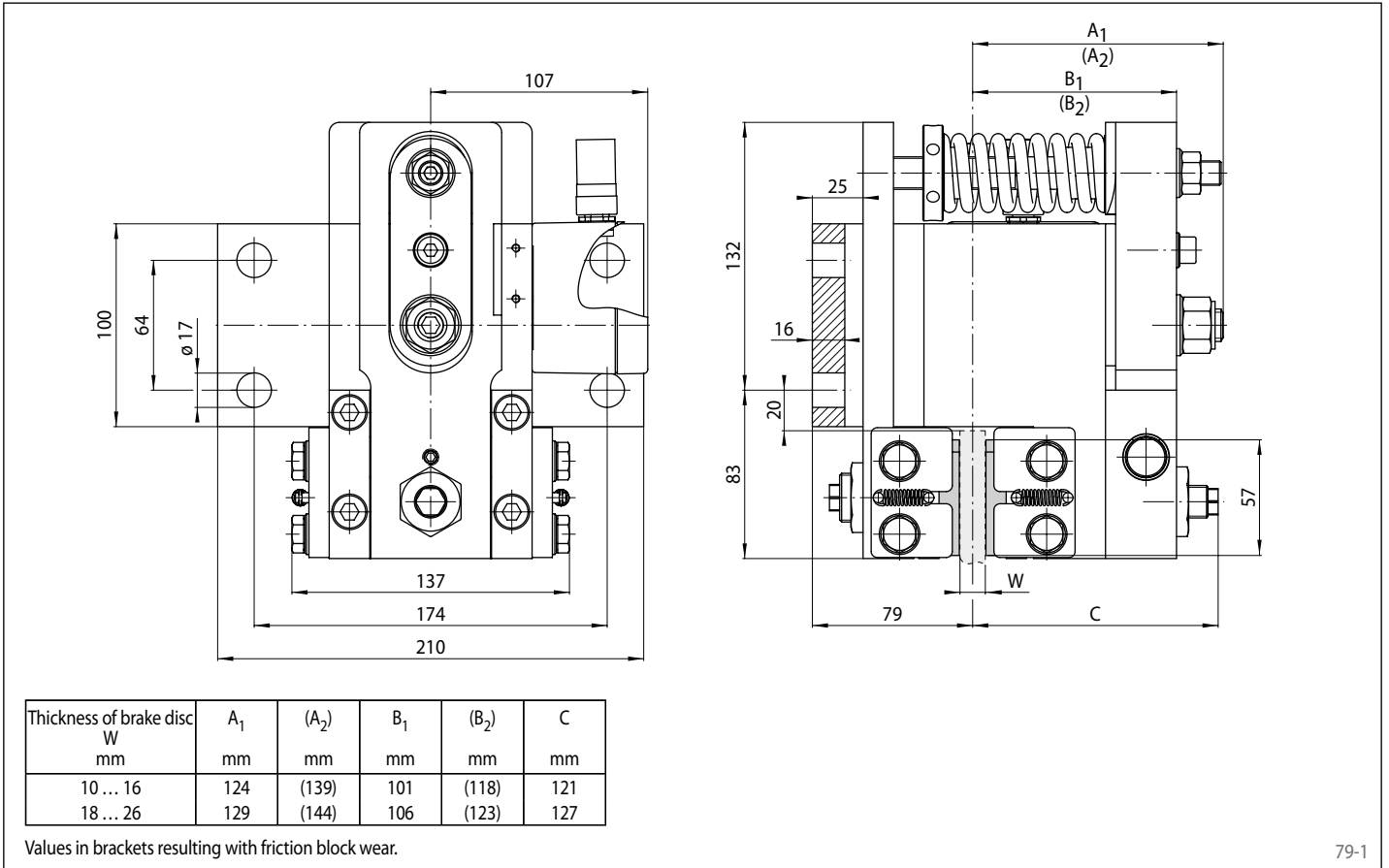

79-1

Brake Caliper EH 028 FEM

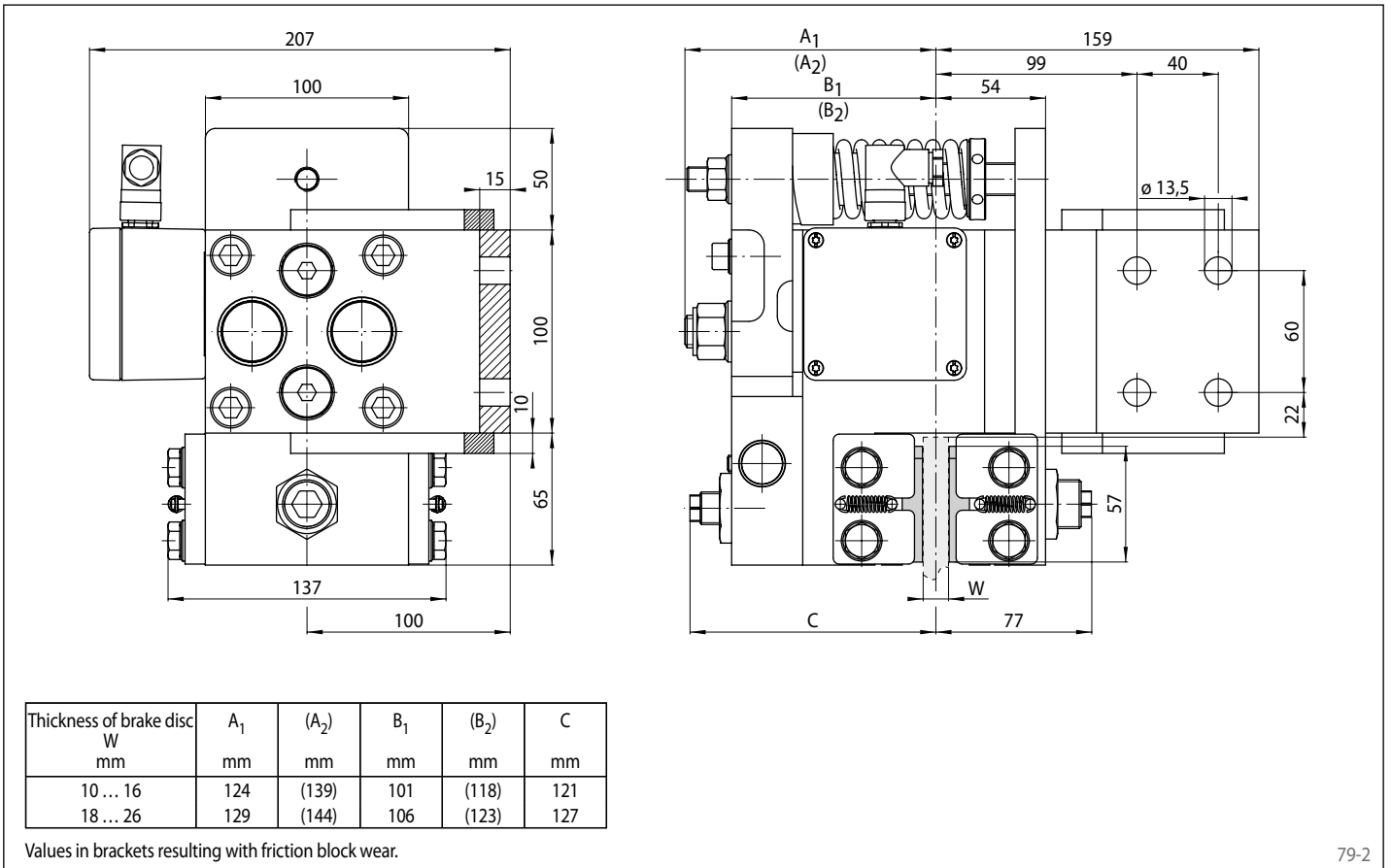

79-2

Brake Calipers EV 038 FEM and EH 038 FEM

spring activated – electromagnetically released



Features	Code
Brake Caliper with electromagnet	E
Mounting to the machine parallel or at right angles to the brake disc	V H
Frame size 038	038
Spring activated	F
Electromagnetically released	E
Manual adjustment to accommodate friction block wear	M
Supply voltage 220 to 240 VAC	240
Supply voltage 380 to 480 VAC	480
Electromagnet mounted in central position	M
Thickness of brake disc 12,5 ... 20 mm	12
or 22 ... 30 mm	25

Example for ordering

Brake Caliper EV 038 FEM, supply voltage 400 VAC, Electromagnet mounted in central position, thickness of brake disc 25 mm:

EV 038 FEM - 480 M - 25

Advantages

The brake caliper EV 038 FEM or EH 038 FEM is a very compact and high efficient disc brake with very low power consumption. Its floating bearing compensates small misalignments of the brake disc. The attached electronic reduces the power consumption in open position automatically.

Options

- Available with cCSAus approval
- Inductive proximity switch: "Brake released"-, "Brake closed"-status and/or "Friction block wear adjustment necessary"

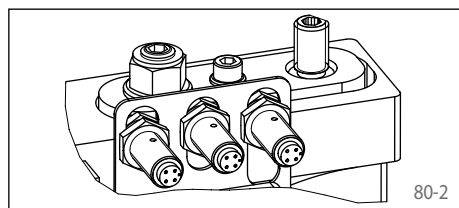

Technical Data

	Brake Calipers EV 038 FEM and EH 038 FEM with supply voltage	
	220 to 240 VAC	380 to 480 VAC
Brake disc diameter	Braking torque	Braking torque
mm	Nm	Nm
430	2830	
520	3550	
630	4430	
710	5070	
800	5790	
900	6590	
Clamping force	20000 N	
Clamping force or braking torque adjustable	60 - 100%	
Power consumption in open position	20 W	24 W
	(100% duty factor)	
Power when opening the brake (< 1 s)	2100 W	2300 W
Fuse rating	10 A, Type "B"	
Max. number of actuation	360/h permanent activations at 20° C ambient temperature	
Actuation frequency*	at least 8 seconds between 2 activations	
Weight	50 kg	

The braking torques shown in the diagram are based on a theoretical friction coefficient of 0,4.

* Shorter actuation frequency on request

Brake Calipers EV 038 FEM and EH 038 FEM

spring activated – electromagnetically released

Brake Caliper EV 038 FEM

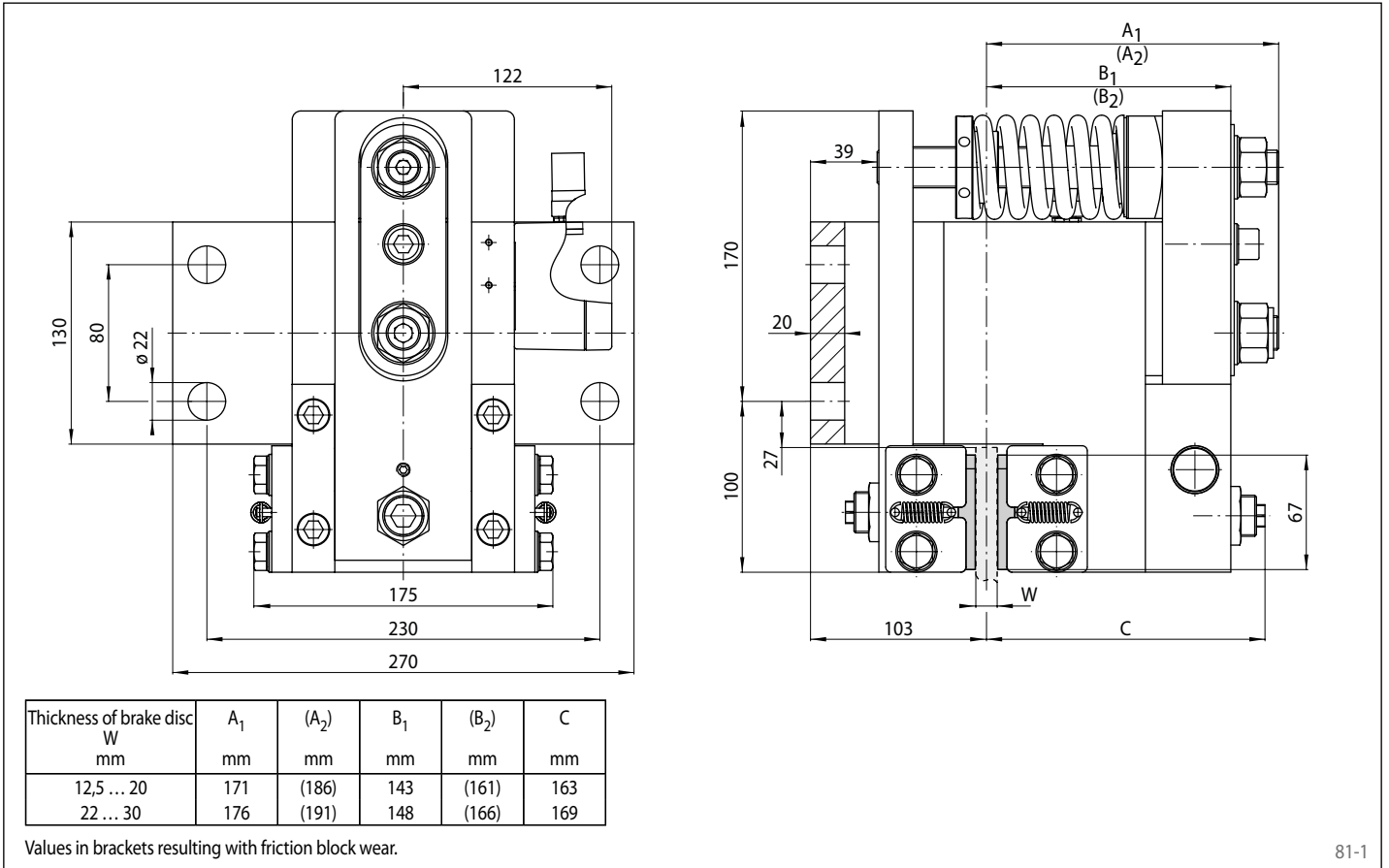

81-1

Brake Caliper EH 038 FEM

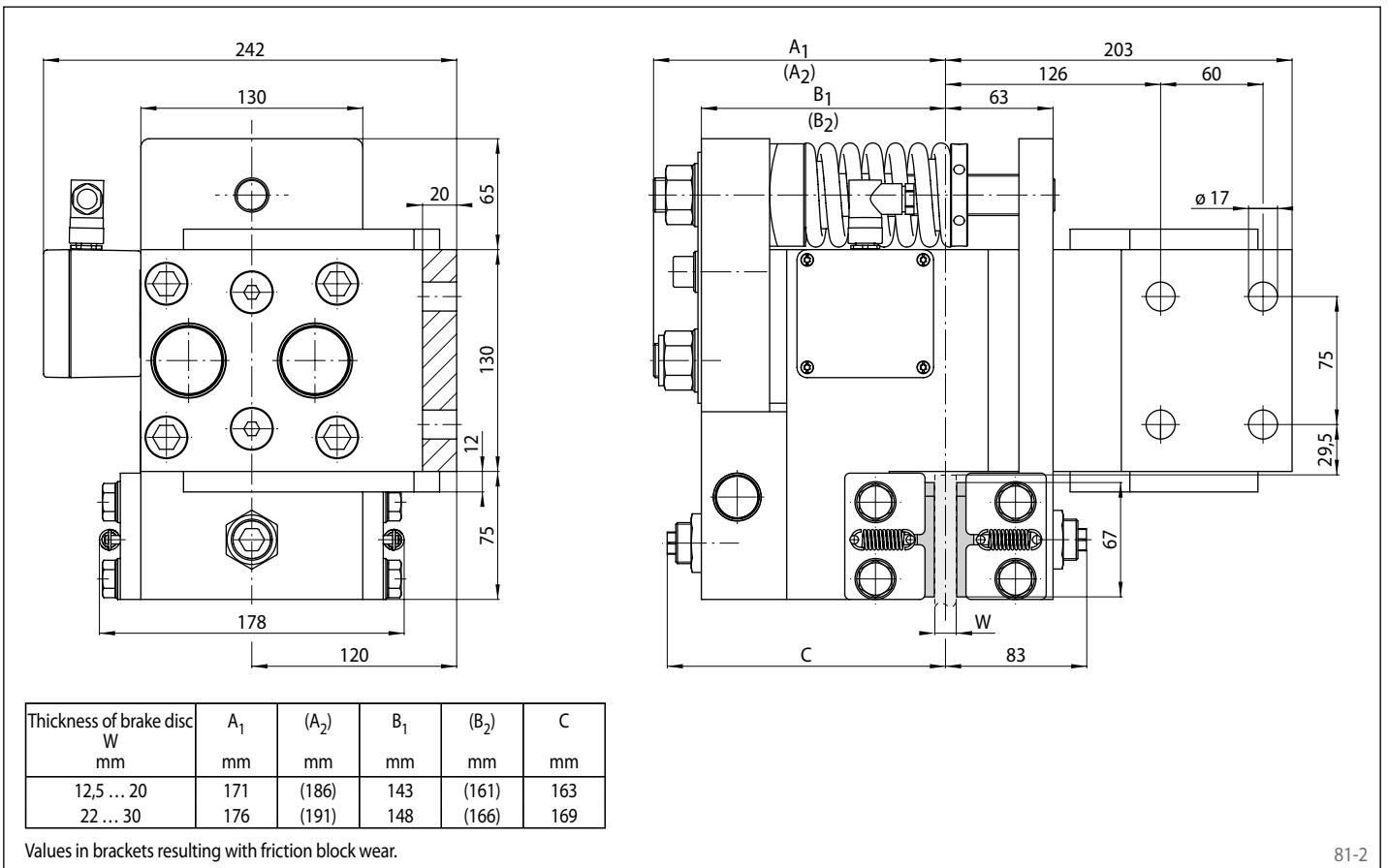

81-2

Brake Calipers EV 018 EFM and EH 018 EFM

electromagnetically activated – spring released

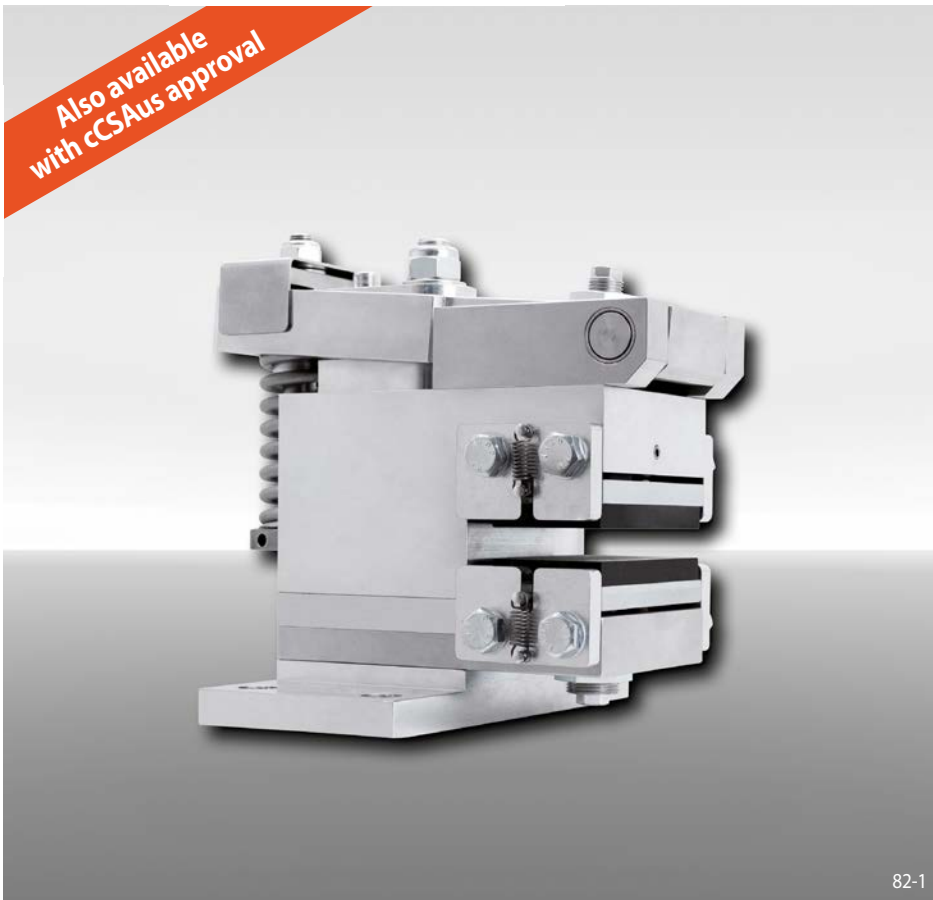

82-1

Advantages

The brake caliper EV 018 EFM or EH 018 EFM is a very compact and high efficient disc brake with very low power consumption. Its floating bearing compensates small misalignments of the brake disc. The separate electronic module (included) reduces the power consumption in closed position automatically.

Options

- Available with cCSAus approval
- Inductive proximity switch: "Brake released"-, "Brake closed"-status and/or "Friction block wear adjustment necessary"

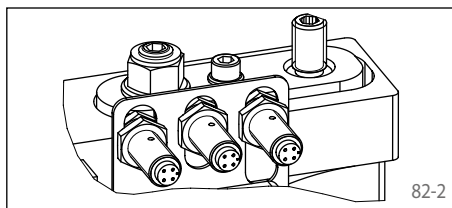

82-2

Electronic module

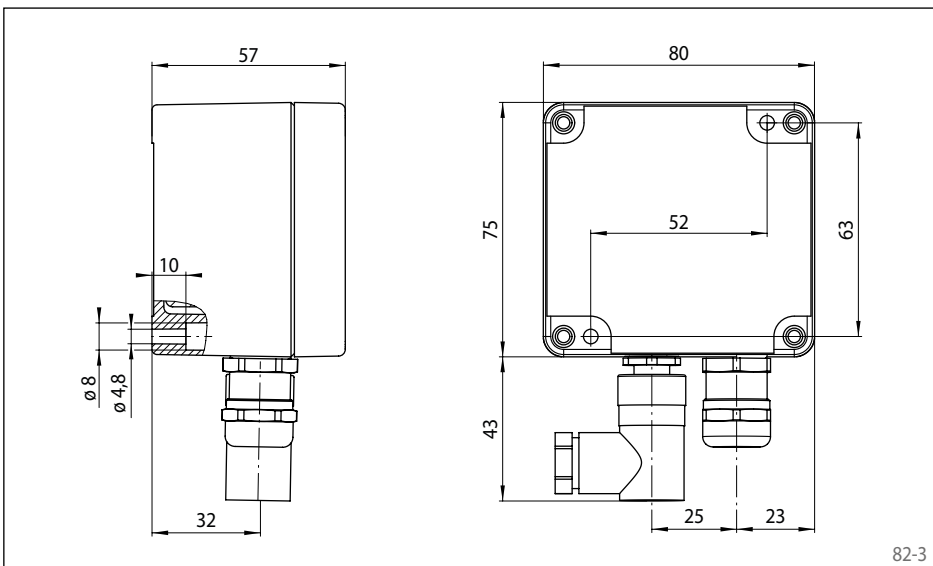

82-3

Features

Features	Code
Brake Caliper with electromagnet	E
Mounting to the machine parallel or at right angles to the brake disc	V H
Frame size 018	018
Electromagnetically activated	E
Spring released	F
Manual adjustment to accommodate friction block wear	M
Supply voltage 220 to 240 VAC	240
Supply voltage 380 to 480 VAC	480
Electromagnet mounted in central position	M
Thickness of brake disc 8 ... 15 mm	12
or 16 ... 20 mm	20

Example for ordering

Brake Caliper EV 018 EFM, supply voltage 400 VAC, Electromagnet mounted in central position, thickness of brake disc 15 mm:

EV 018 EFM - 480 M - 12

Technical Data

	Brake Calipers EV 018 EFM and EH 018 EFM with supply voltage	
	220 to 240 VAC	380 to 480 VAC
Brake disc diameter mm		
	Braking torque Nm	Braking torque Nm
125	100	
150	130	
200	200	
250	260	
300	320	
355	400	
Clamping force	3 200 N	
Clamping force or braking torque adjustable	50 - 100%	
Power consumption in closed position	24 W	32 W (100% duty factor)
Power when closing the brake (< 1 s)	800 W	1 200 W
Fuse rating	10 A, Type "B"	
Max. number of actuation	360/h permanent activations at 20 °C ambient temperature	
Actuation frequency*	at least 8 seconds between 2 activations	
Weight	6,5 kg	

The braking torques shown in the diagram are based on a theoretical friction coefficient of 0,4.

* Shorter actuation frequency on request

Brake Calipers EV 018 EFM and EH 018 EFM

electromagnetically activated – spring released

Brake Caliper EV 018 EFM

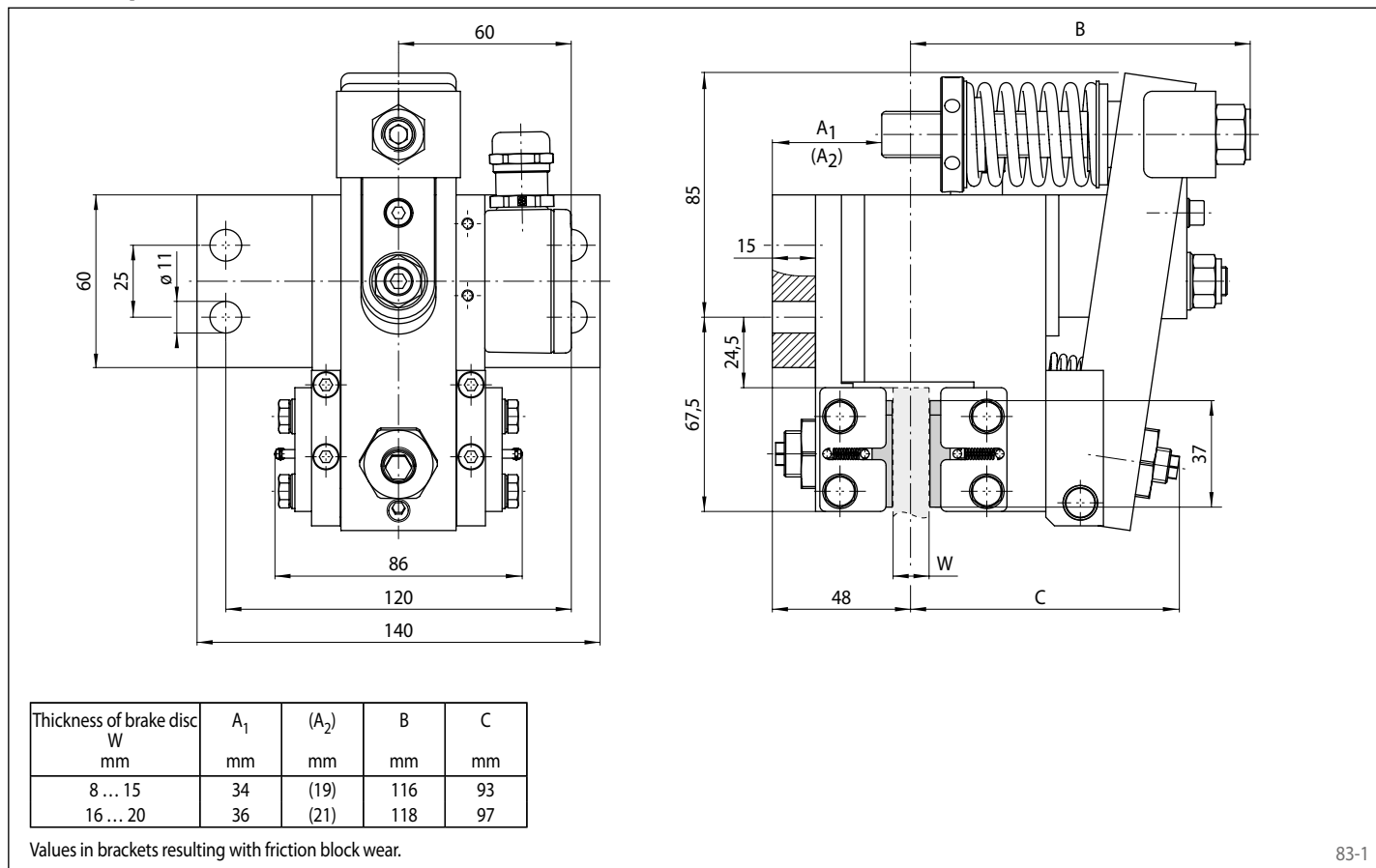

83-1

Brake Caliper EH 018 EFM

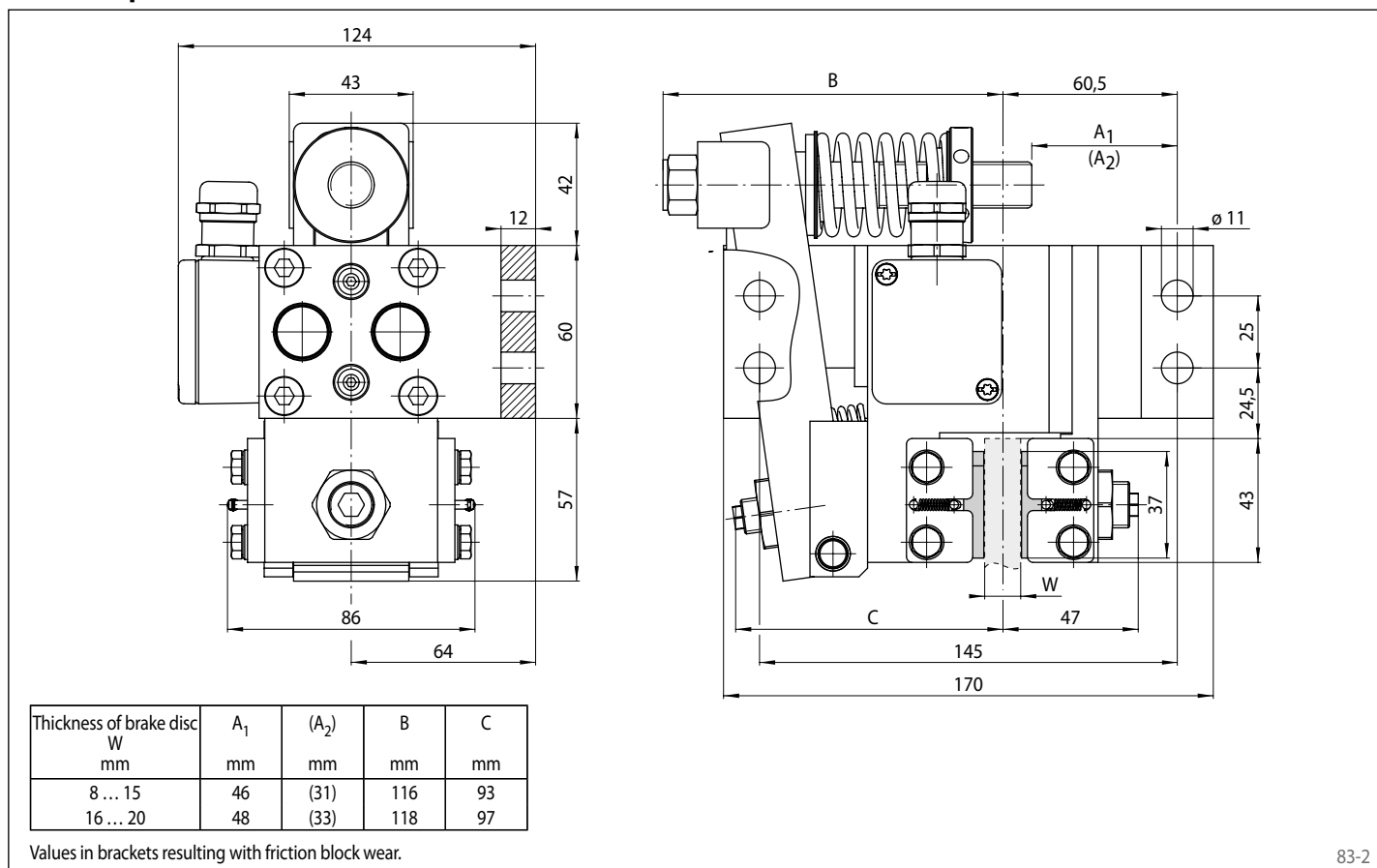

83-2

Brake Calipers EV 024 EFM and EH 024 EFM

electromagnetically activated – spring released



Features	Code
Brake Caliper with electromagnet	E
Mounting to the machine parallel or at right angles to the brake disc	V H
Frame size 024	024
Electromagnetically activated	E
Spring released	F
Manual adjustment to accommodate friction block wear	M
Supply voltage 220 to 240 VAC	240
Supply voltage 380 to 480 VAC	480
Electromagnet mounted in central position	M
Thickness of brake disc 10 ... 16 mm	12
or 18 ... 26 mm	25

Example for ordering

Brake Caliper EV 024 EFM, supply voltage 400 VAC, electromagnet mounted in central position, thickness of brake disc 15 mm:

EV 024 EFM - 480 M - 12

Advantages

The brake caliper EV 024 EFM or EH 024 EFM is a very compact and high efficient disc brake with very low power consumption. Its floating bearing compensates small misalignments of the brake disc. The attached electronic reduces the power consumption in closed position automatically.

Options

- Available with cCSAus approval
- Inductive proximity switch: "Brake released"-, "Brake closed"-status and/or "Friction block wear adjustment necessary"

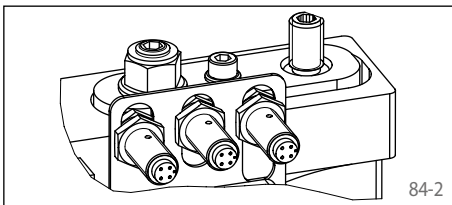

Technical Data

	Brake Calipers EV 024 EFM and EH 024 EFM with supply voltage	
	220 to 240 VAC	380 to 480 VAC
Brake disc diameter	Braking torque	Braking torque
mm	Nm	Nm
250	440	
300	550	
355	670	
430	830	
520	1 030	
630	1 270	
Clamping force	5 500 N	
Clamping force or braking torque adjustable	60 - 100%	
Power consumption in closed position	20 W	20 W (100% duty factor)
Power when closing the brake (< 1 s)	2 850 W	1 800 W
Fuse rating	10 A, Type "B"	
Max. number of actuation	360/h permanent activations at 20 °C ambient temperature	
Actuation frequency*	at least 8 seconds between 2 activations	
Weight	13 kg	

The braking torques shown in the diagram are based on a theoretical friction coefficient of 0,4.

* Shorter actuation frequency on request

Brake Calipers EV 024 EFM and EH 024 EFM

electromagnetically activated – spring released

Brake Caliper EV 024 EFM

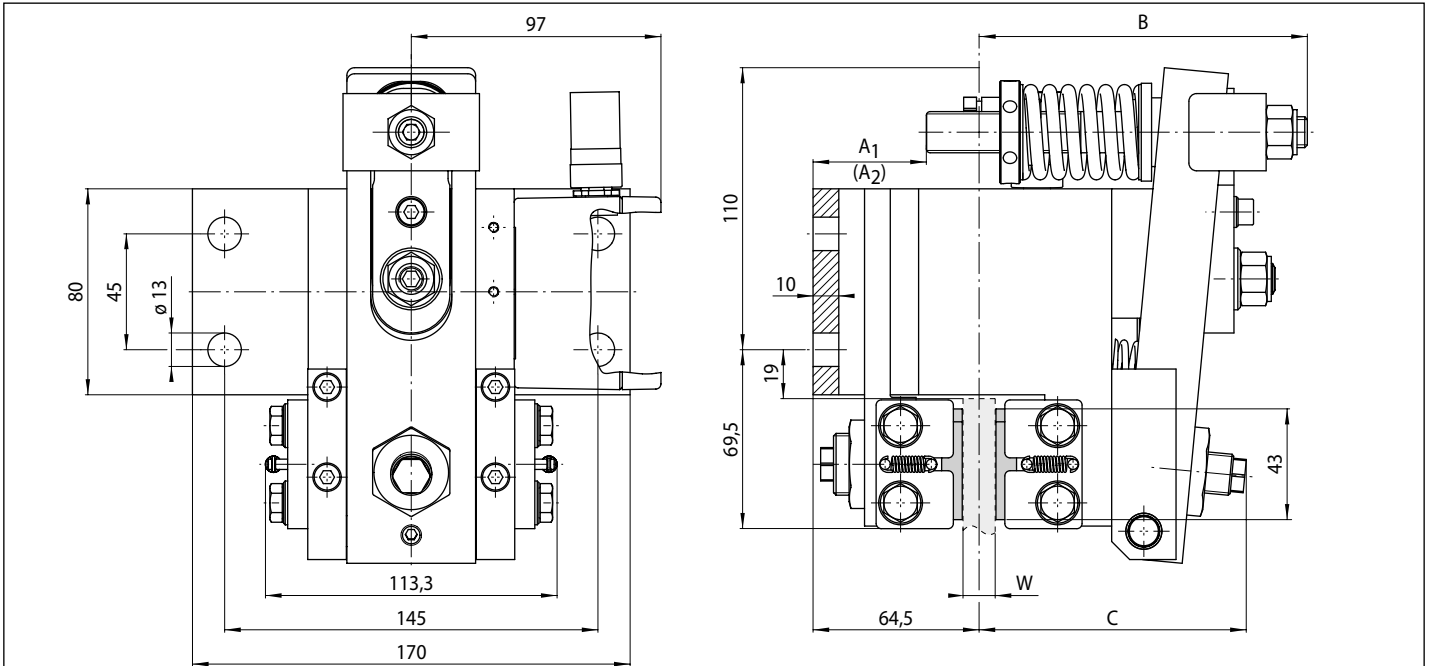

Thickness of brake disc W mm	A ₁ mm	(A ₂) mm	B mm	C mm
10 ... 16	43,5	(28,5)	127	104
18 ... 26	48,5	(33,5)	132	110

Values in brackets resulting with friction block wear.

85-1

Brake Caliper EH 024 EFM

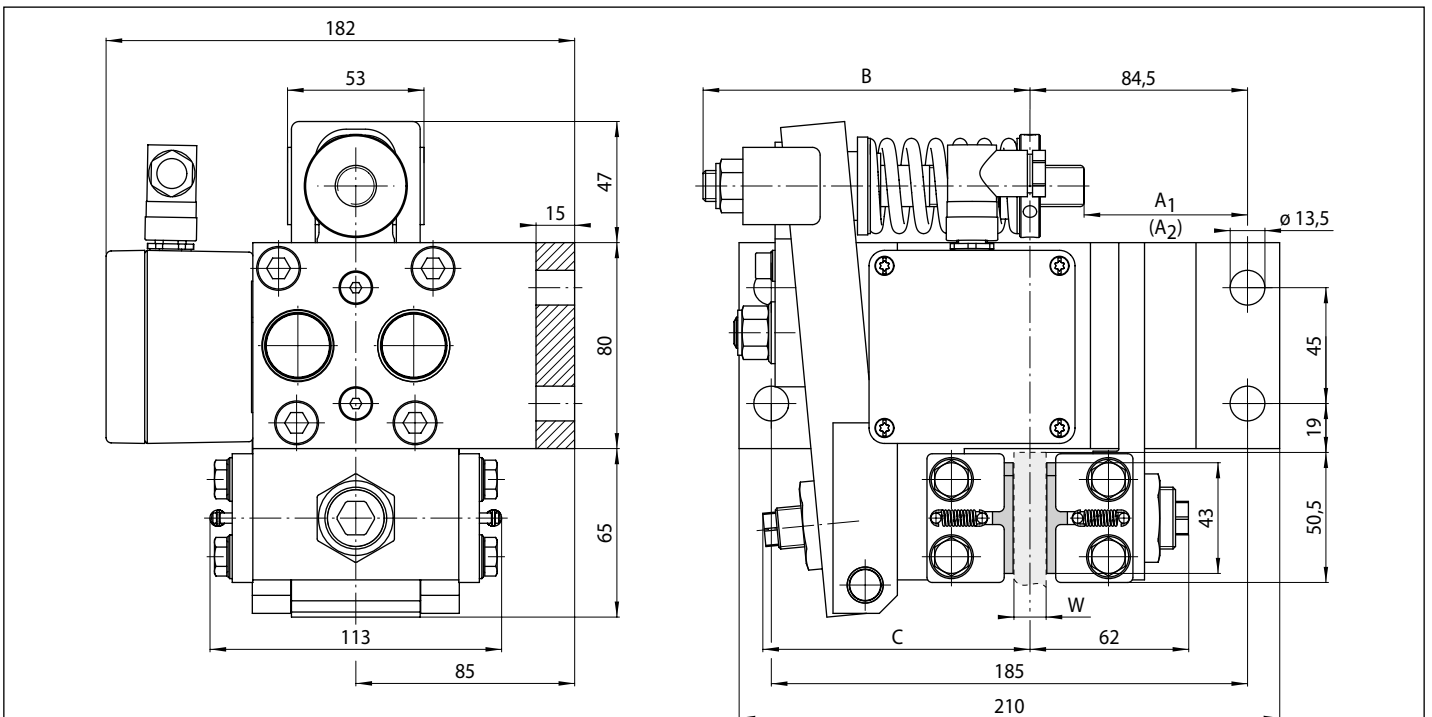

Thickness of brake disc W mm	A ₁ mm	(A ₂) mm	B mm	C mm
10 ... 16	63,5	(48,5)	127	104
18 ... 26	68,5	(53,5)	132	110

Values in brackets resulting with friction block wear.

85-2

Brake Calipers EV 028 EFM and EH 028 EFM

electromagnetically activated – spring released

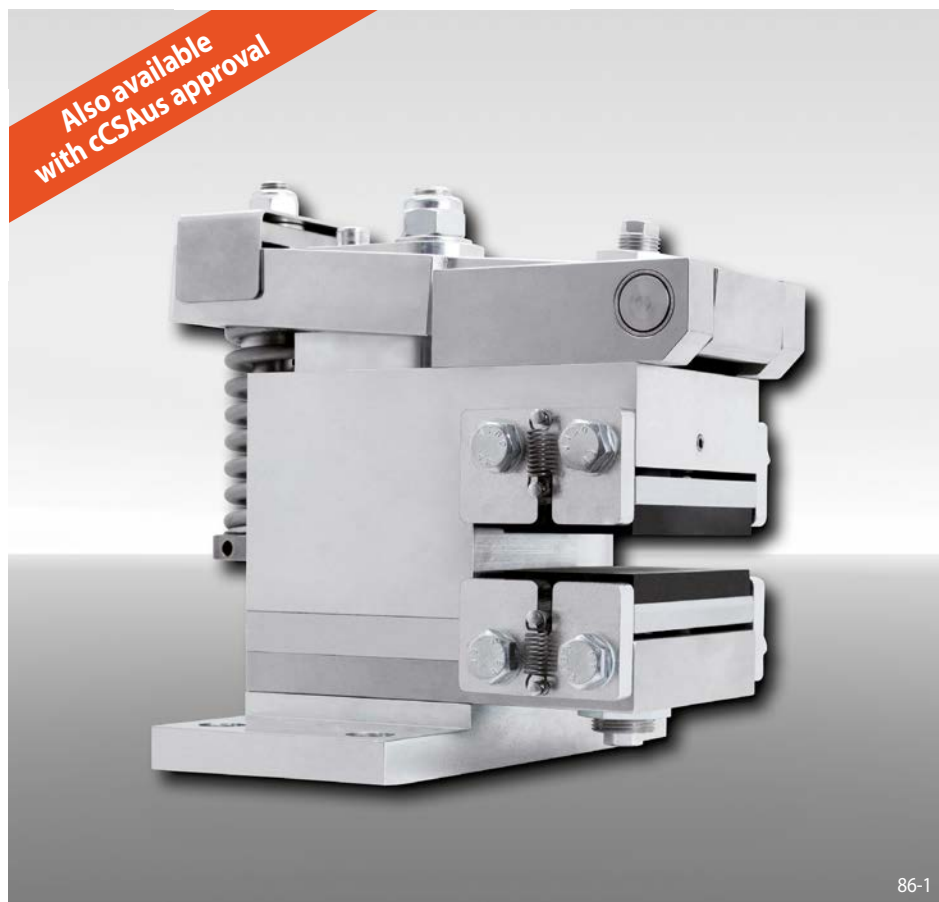

Features	Code
Brake Caliper with electromagnet	E
Mounting to the machine parallel or at right angles to the brake disc	V H
Frame size 028	028
Electromagnetically activated	E
Spring released	F
Manual adjustment to accommodate friction block wear	M
Supply voltage 220 to 240 VAC	240
Supply voltage 380 to 480 VAC	480
Electromagnet mounted in central position	M
Thickness of brake disc 10 ... 16 mm	12
or 18 ... 26 mm	25

Example for ordering

Brake Caliper EV 028 EFM, supply voltage 400 VAC, electromagnet mounted in central position, thickness of brake disc 15 mm:

EV 028 EFM - 480 M - 12

Advantages

The brake caliper EV 028 EFM or EH 028 EFM is a very compact and high efficient disc brake with very low power consumption. Its floating bearing compensates small misalignments of the brake disc. The attached electronic reduces the power consumption in closed position automatically.

Options

- Available with cCSAus approval
- Inductive proximity switch: "Brake released"-, "Brake closed"-status and/or "Friction block wear adjustment necessary"

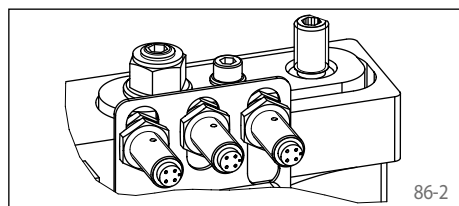

Technical Data

	Brake Calipers EV 028 EFM and EH 028 EFM with supply voltage	
	220 to 240 VAC	380 to 480 VAC
Brake disc diameter	Braking torque	Braking torque
mm	Nm	Nm
300	1 170	
355	1 450	
430	1 820	
520	2 270	
630	2 820	
710	3 220	
Clamping force	12 500 N	
Clamping force or braking torque adjustable	70 - 100%	
Power consumption in closed position	15 W	19 W (100% duty factor)
Power when closing the brake (< 1 s)	1 850 W	2 500 W
Fuse rating	10 A, Type "B"	
Max. number of actuation	360/h permanent activations at 20 °C ambient temperature	
Actuation frequency*	at least 8 seconds between 2 activations	
Weight	24 kg	

The braking torques shown in the diagram are based on a theoretical friction coefficient of 0,4.

* Shorter actuation frequency on request

Brake Calipers EV 028 EFM and EH 028 EFM

electromagnetically activated – spring released

Brake Caliper EV 028 EFM

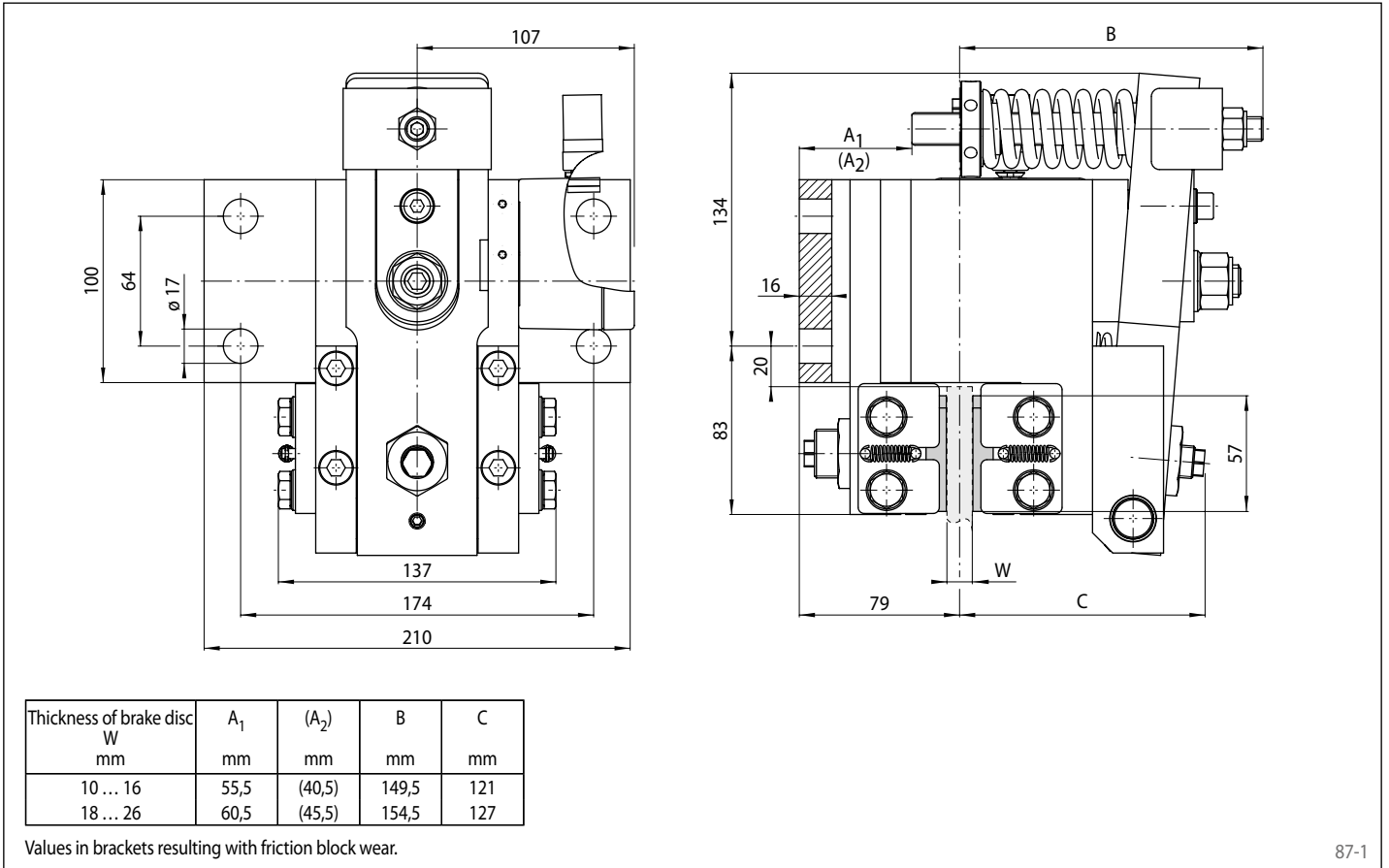

87-1

Brake Caliper EH 028 EFM

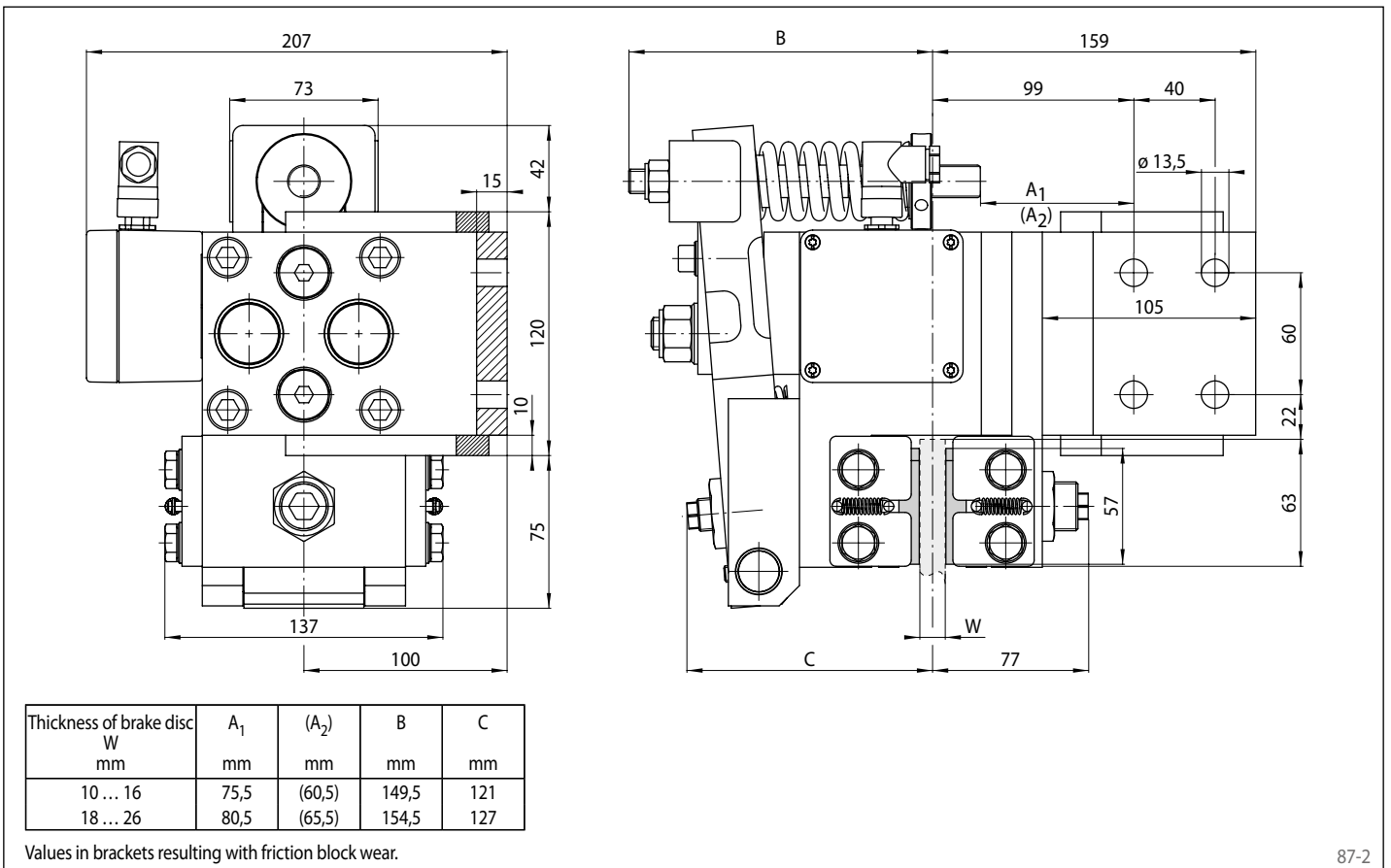

87-2

Brake Calipers EV 038 EFM and EH 038 EFM

electromagnetically activated – spring released



Features	Code
Brake Caliper with electromagnet	E
Mounting to the machine parallel or at right angles to the brake disc	V H
Frame size 038	038
Electromagnetically activated	E
Spring released	F
Manual adjustment to accommodate friction block wear	M
Supply voltage 220 to 240 VAC	240
Supply voltage 380 to 480 VAC	480
Electromagnet mounted in central position	M
Thickness of brake disc 12,5 ... 20 mm	12
or 22 ... 30 mm	25

Example for ordering

Brake Caliper EV 038 EFM, supply voltage 400 VAC, electromagnet mounted in central position, thickness of brake disc 25 mm:

EV 038 EFM - 480 M - 25

Advantages

The brake caliper EV 038 EFM or EH 038 EFM is a very compact and high efficient disc brake with very low power consumption. Its floating bearing compensates small misalignments of the brake disc. The attached electronic reduces the power consumption in closed position automatically.

Options

- Available with cCSAus approval
- Inductive proximity switch: "Brake released"-, "Brake closed"-status and/or "Friction block wear adjustment necessary"

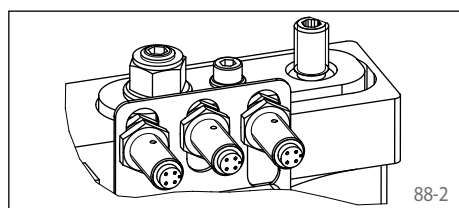

Technical Data

	Brake Calipers EV 038 EFM and EH 038 EFM with supply voltage	
	220 to 240 VAC	380 to 480 VAC
Brake disc diameter	Braking torque	Braking torque
mm	Nm	Nm
430	3 400	
520	4 250	
630	5 320	
710	6 090	
800	6 950	
900	7 910	
Clamping force	24 000 N	
Clamping force or braking torque adjustable	70 - 100%	
Power consumption in closed position	20 W	24 W
	(100% duty factor)	
Power when closing the brake (< 1 s)	2 100 W	2 300 W
Fuse rating	10 A, Type "B"	
Max. number of actuation	360/h permanent activations at 20 °C ambient temperature	
Actuation frequency*	at least 8 seconds between 2 activations	
Weight	50 kg	

The braking torques shown in the diagram are based on a theoretical friction coefficient of 0,4.

* Shorter actuation frequency on request

Brake Calipers EV 038 EFM and EH 038 EFM

electromagnetically activated – spring released

Brake Caliper EV 038 EFM

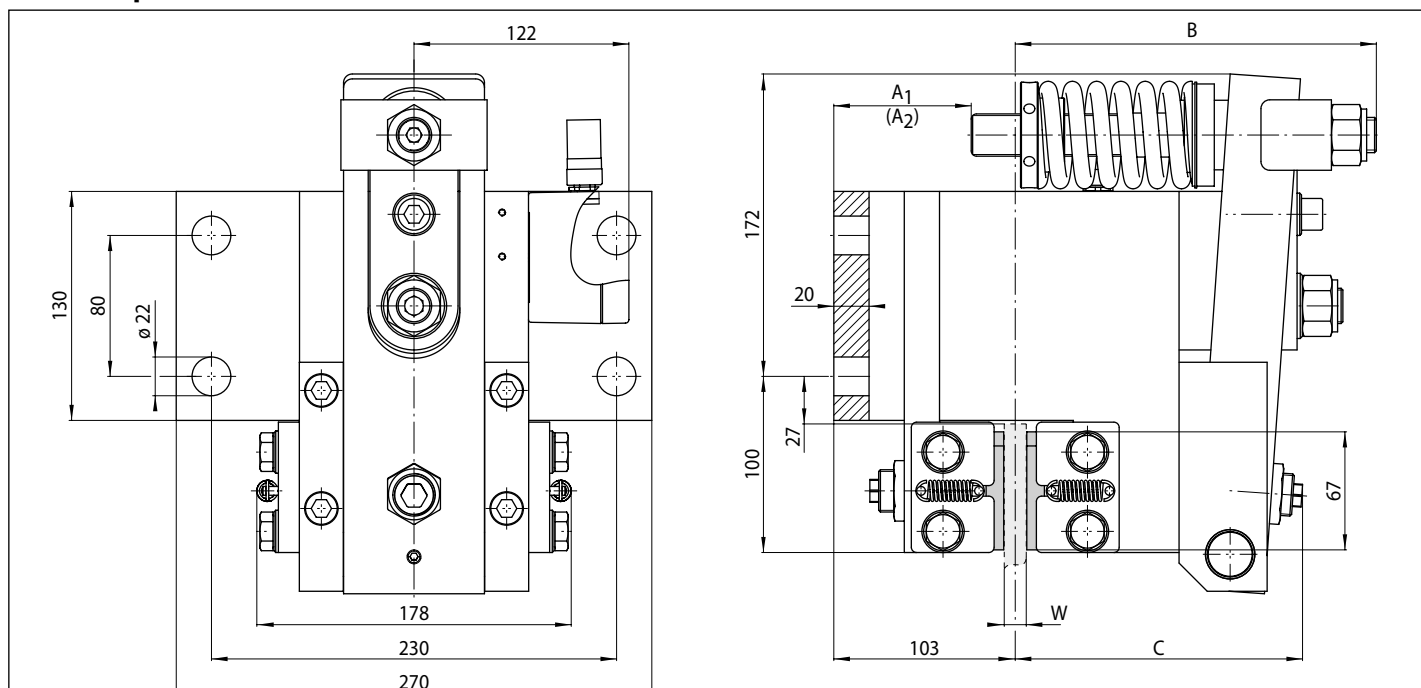

Thickness of brake disc W mm	A ₁ mm	(A ₂) mm	B ₁ mm	C mm
12,5 ... 20	74	(59)	201	163
22 ... 30	79	(64)	206	169

Values in brackets resulting with friction block wear.

89-1

Brake Caliper EH 038 EFM

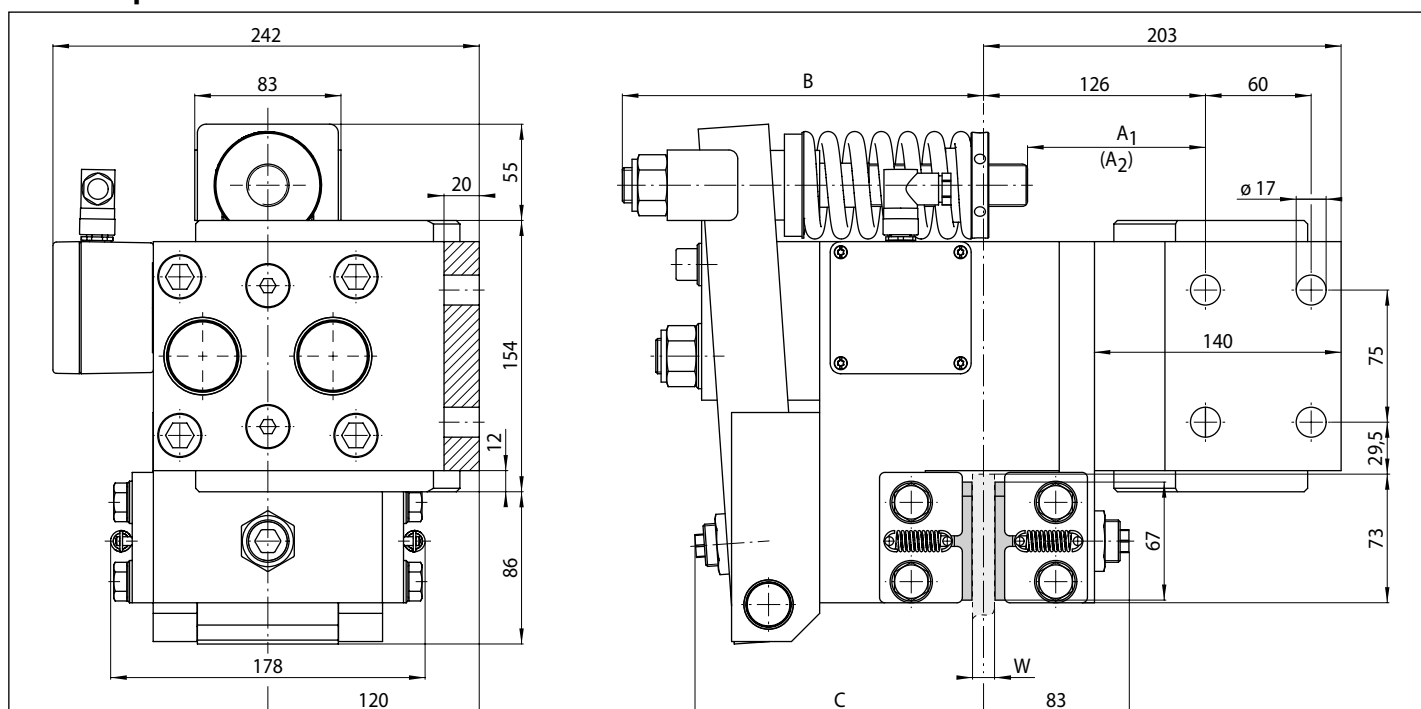

Thickness of brake disc W mm	A ₁ mm	(A ₂) mm	B ₁ mm	C mm
12,5 ... 20	97	(82)	201	163
22 ... 30	102	(87)	206	169

Values in brackets resulting with friction block wear.

89-2

Brake Caliper HS 075 FHM

spring activated – hydraulically released
for wind turbines or conveyor systems

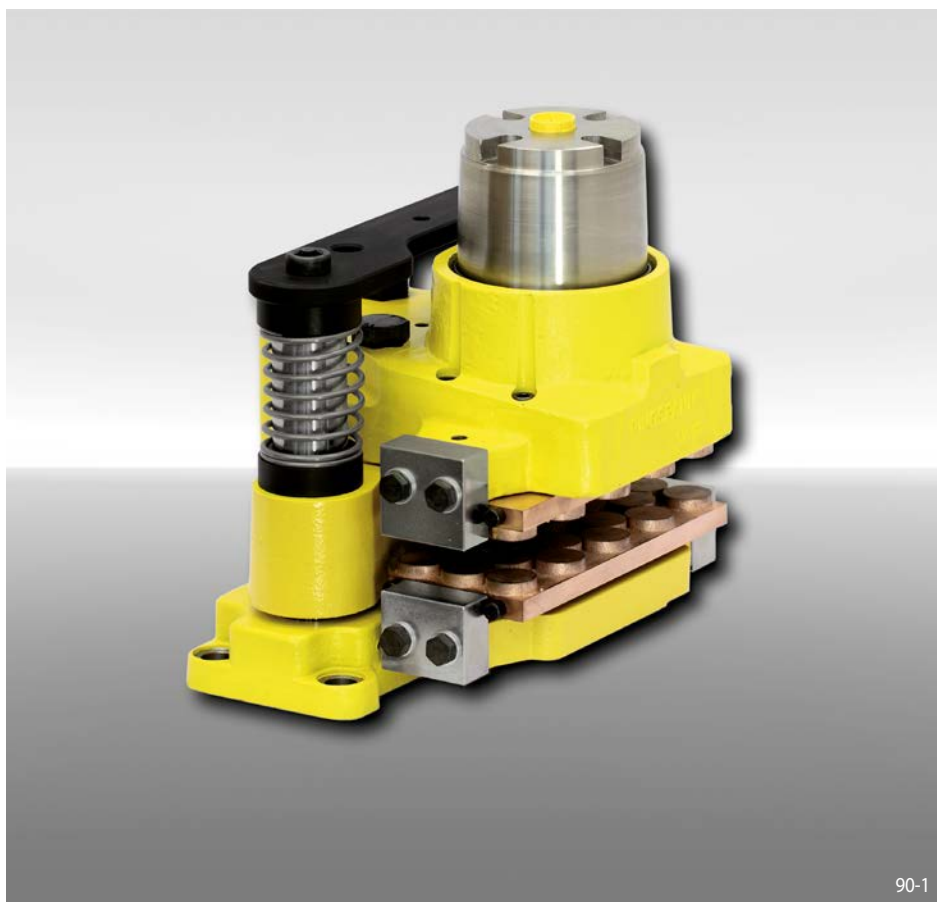

Features	Code
Brake Caliper	H
Floating caliper	S
Frame size 075	075
Spring activated	F
Hydraulically released	H
Manual adjustment to accommodate friction block wear	M
Spring packages available for clamping forces of 10 kN, 20 kN, 30 kN, 40 kN or 55 kN	010 to 055

Example for ordering

Brake Caliper HS 075 FHM, spring package for clamping force 10 kN:

HS 075 FHM - 010

Technical Data

	Brake Caliper HS 075 FHM				
	with spring package 010	with spring package 020	with spring package 030	with spring package 040	with spring package 055
Brake disc diameter	Braking torque	Braking torque	Braking torque	Braking torque	Braking torque
mm	Nm	Nm	Nm	Nm	Nm
520	1500	2900	4400	5900	8100
630	1900	3800	5700	7600	10400
710	2200	4400	6600	8800	12100
900	3000	5900	8900	11900	16300
1250	4400	8700	13100	17500	24000
1600	5800	11500	17300	23100	31800
2000	7400	14700	22100	29500	40500
Clamping force	10 kN	20 kN	30 kN	40 kN	55 kN
Oil pressure	min. 25 bar max. 140 bar	min. 50 bar max. 140 bar	min. 70 bar max. 140 bar	min. 95 bar max. 140 bar	min. 125 bar max. 140 bar
Oil volume	max. 82 cm ³	max. 82 cm ³	max. 82 cm ³	max. 82 cm ³	max. 82 cm ³
Weight	95 kg	95 kg	95 kg	95 kg	95 kg

The braking torques shown in the table are based on a theoretical friction coefficient of 0.4.

Brake Caliper HS 075 FHM

spring activated – hydraulically released
for wind turbines or conveyor systems

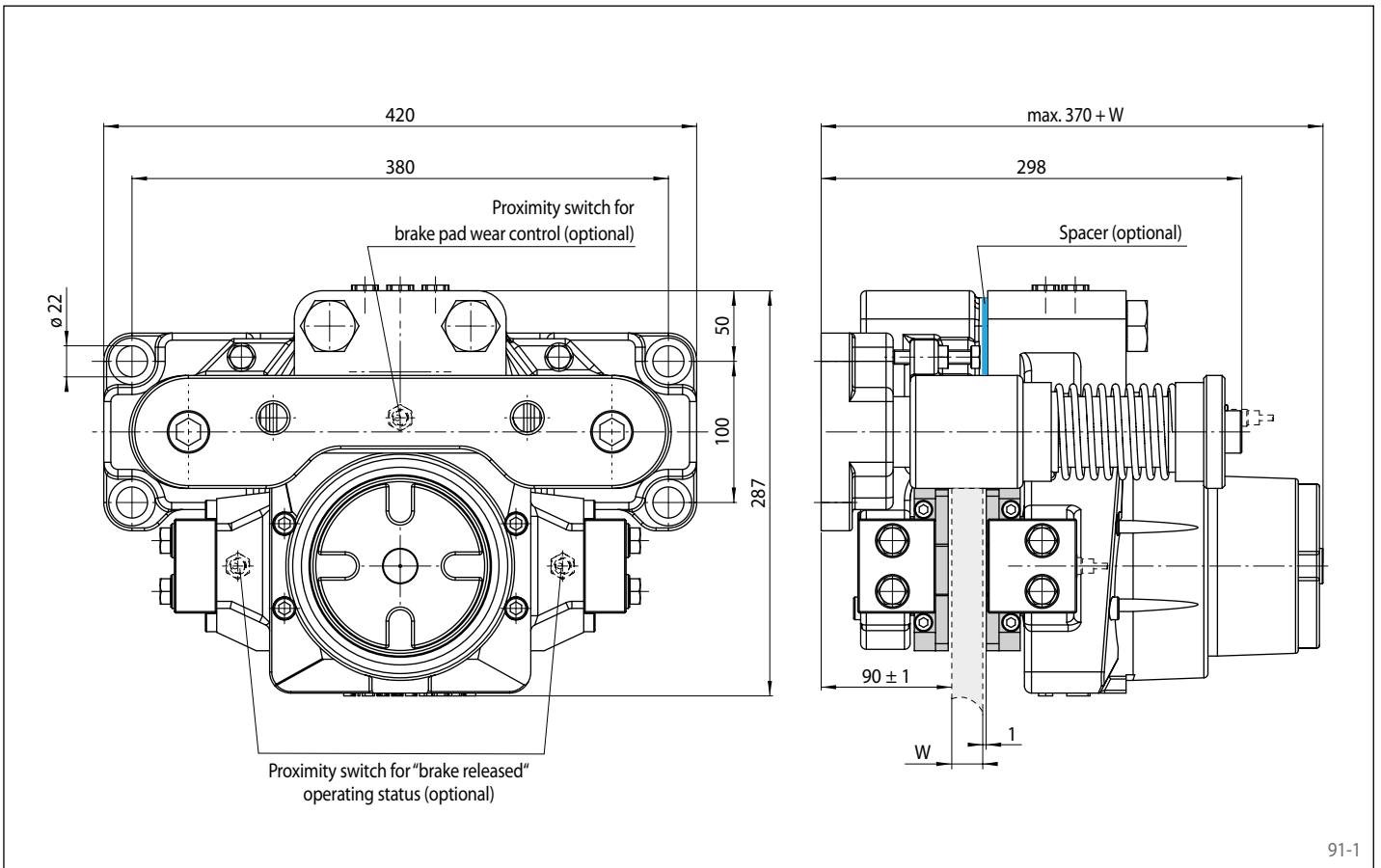

91-1

Mounting

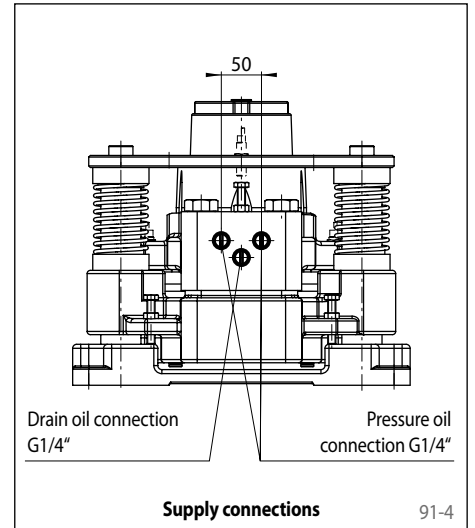
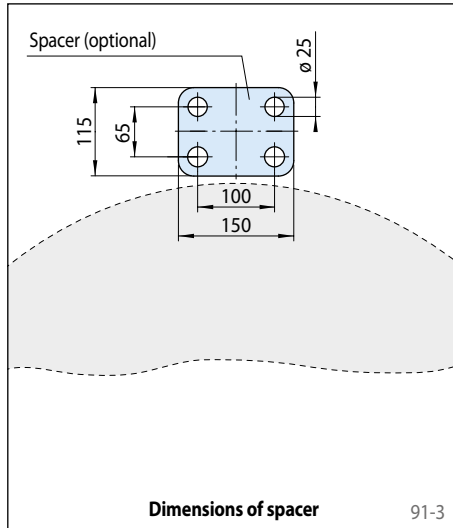
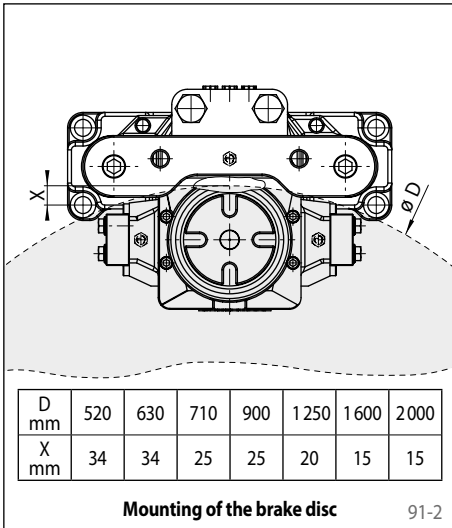

Other features

- High safety against leakage
- Easy change of friction blocks
- Painted with surface coating class C4-L according to ISO 12944
- For brake disc thickness $W = 20$ mm; brake disc thicknesses of up to 40 mm can be achieved with the use of a spacer installed by the customer

Accessories

- Inductive proximity switch for "brake released" operating status
- Inductive proximity switch for brake pad wear control
- Optional painting with surface coating class C4-H or C5M-H (offshore) according to ISO 12944

Brake Caliper HW 075 FHM

spring activated – hydraulically released

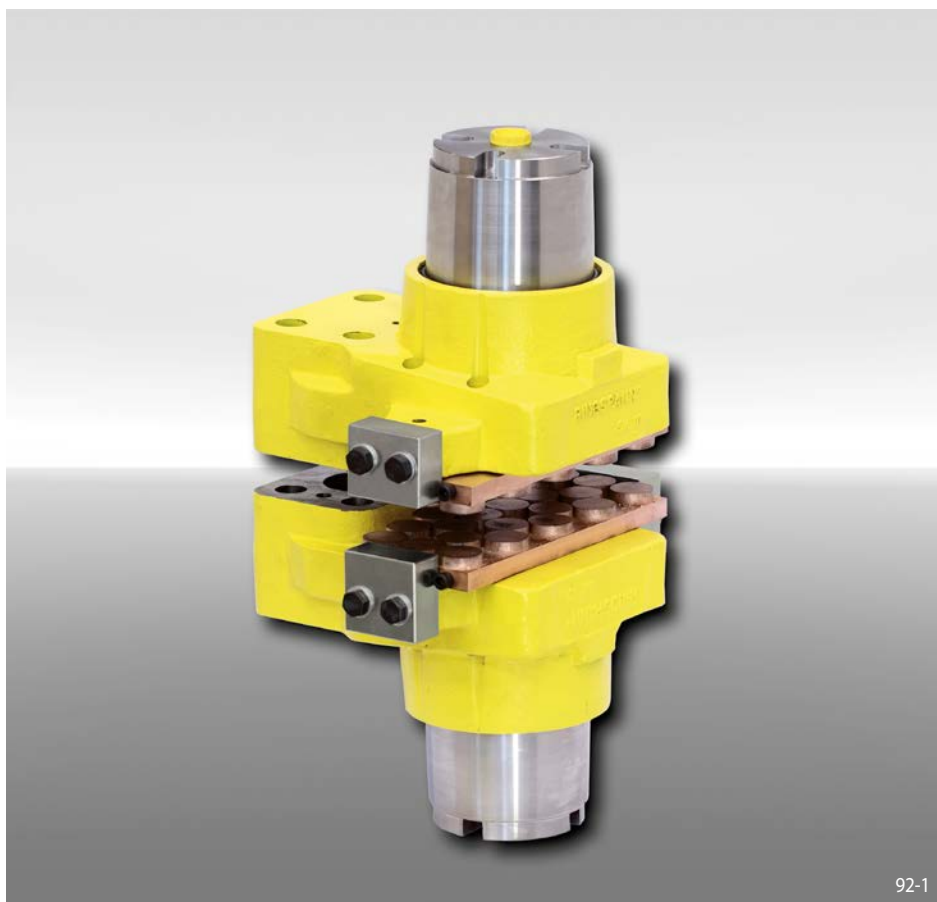

Features	Code
Brake Caliper	H
Standard	W
Frame size 075	075
Spring activated	F
Hydraulically released	H
Manual adjustment to accommodate friction block wear	M
Spring packages available for clamping forces of 10 kN, 20 kN, 30 kN, 40 kN or 55 kN	010 to 055

Example for ordering

Brake Caliper HW 075 FHM, spring package for clamping force 10 kN:

HW 075 FHM - 010

Technical Data

	Brake Caliper HW 075 FHM				
	with spring package 010	with spring package 020	with spring package 030	with spring package 040	with spring package 055
Brake disc diameter	Braking torque	Braking torque	Braking torque	Braking torque	Braking torque
mm	Nm	Nm	Nm	Nm	Nm
520	1500	3000	4400	5900	8100
630	1900	3800	5700	7600	10400
710	2200	4400	6600	8800	12100
900	3000	5900	8900	11900	16300
1250	4400	8700	13100	17500	24000
1600	5800	11500	17300	23100	31800
2000	7400	14700	22100	29500	40500
Clamping force	10 kN	20 kN	30 kN	40 kN	55 kN
Oil pressure	min. 25 bar max. 140 bar	min. 50 bar max. 140 bar	min. 70 bar max. 140 bar	min. 95 bar max. 140 bar	min. 125 bar max. 140 bar
Oil volume	max. 89 cm ³	max. 89 cm ³	max. 89 cm ³	max. 89 cm ³	max. 89 cm ³
Weight	90 kg	90 kg	90 kg	90 kg	90 kg

The braking torques shown in the table are based on a theoretical friction coefficient of 0.4.

Brake Caliper HW 075 FHM

spring activated – hydraulically released

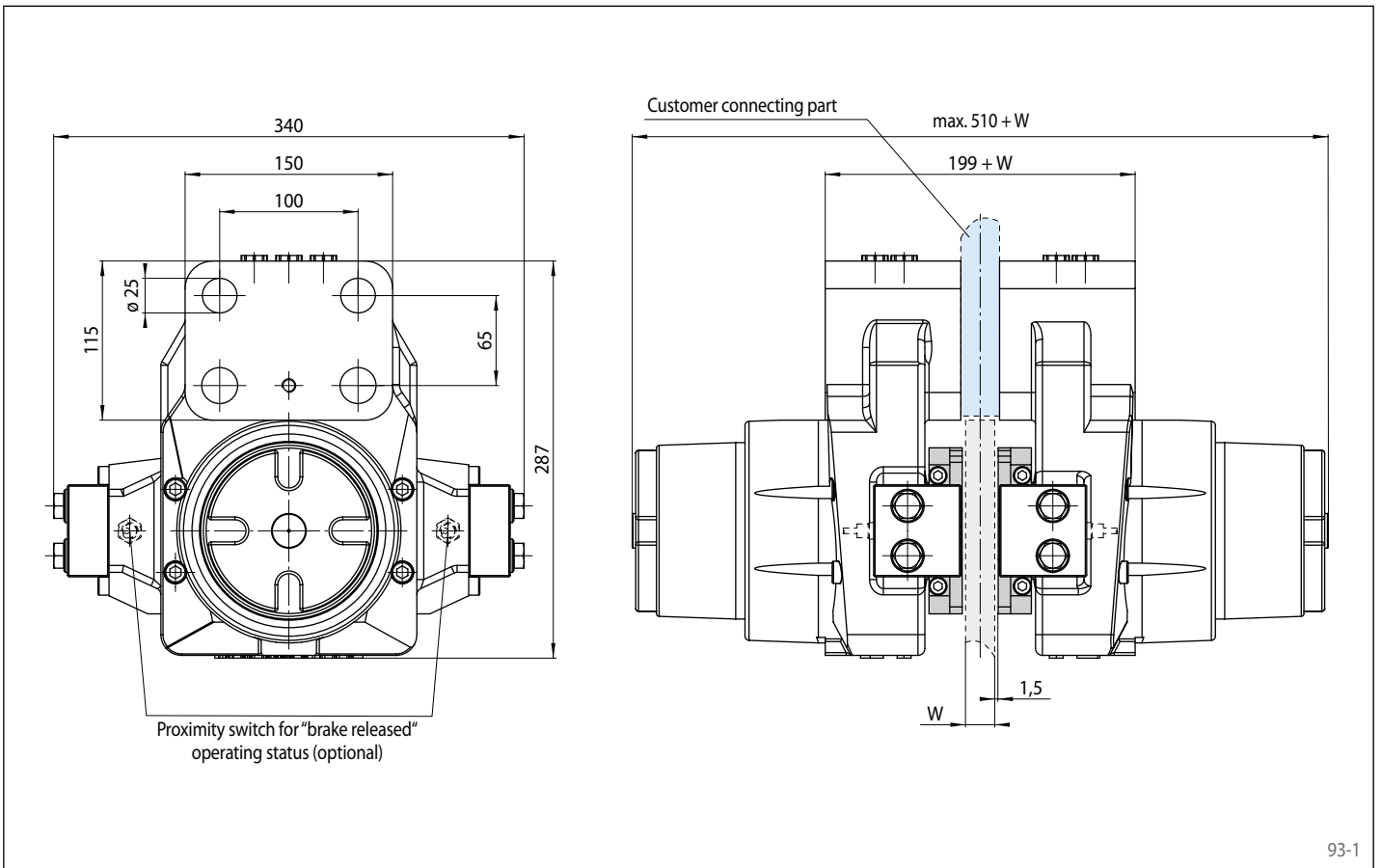

93-1

Mounting

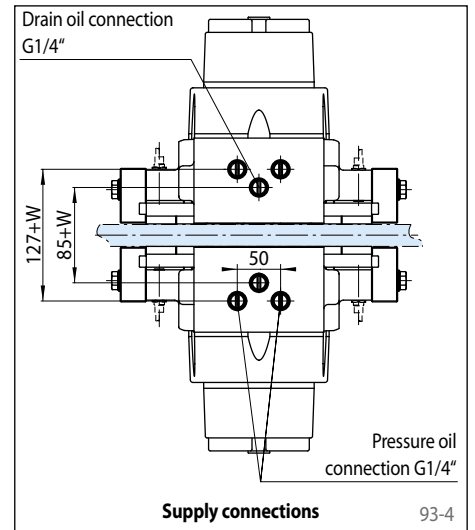
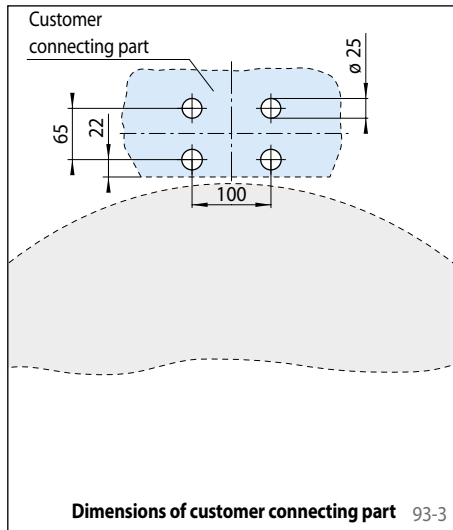
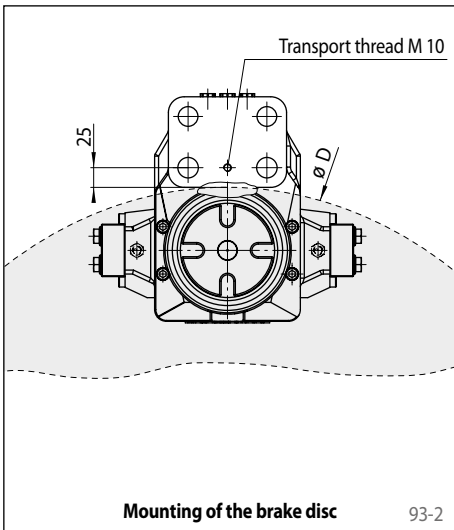

Other features

- High safety against leakage
- Easy change of friction blocks
- Painted with surface coating class C4-L according to ISO 12944
- The thickness of the customer connecting part results from the thickness of the brake disc W plus 3 mm

Accessories

- Inductive proximity switch for "brake released" operating status
- Optional painting with surface coating class C4-H or C5M-H (offshore) according to ISO 12944

Brake Caliper HS 120 FHM

spring activated – hydraulically released
for wind turbines or conveyor systems

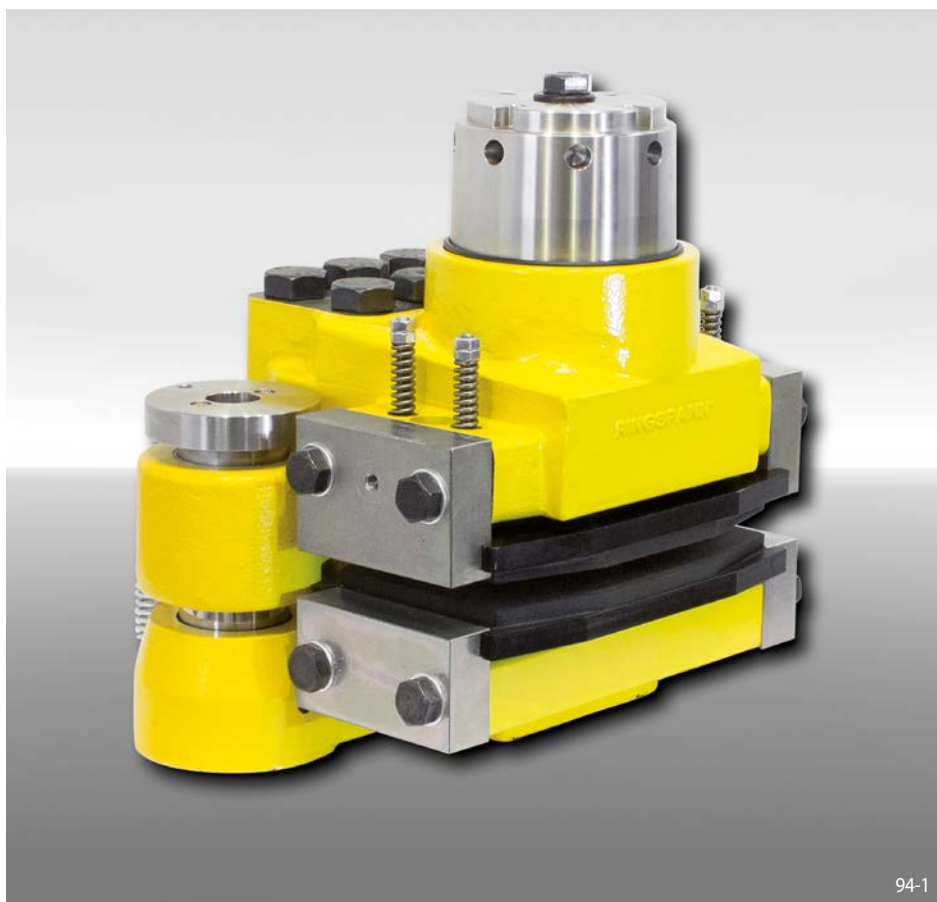

Features	Code
Brake Caliper	H
Floating caliper	S
Frame size 120	120
Spring activated	F
Hydraulically released	H
Manual adjustment to accommodate friction block wear	M
Spring packages available for clamping forces of 30 kN, 50 kN, 70 kN, 100 kN or 120 kN	030 to 120

Example for ordering

Brake Caliper HS 120 FHM, spring package for clamping force 30 kN:

HS 120 FHM - 030

Technical Data

	Brake Caliper HS 120 FHM				
	with spring package 030	with spring package 050	with spring package 070	with spring package 100	with spring package 120
Brake disc diameter	Braking torque	Braking torque	Braking torque	Braking torque	Braking torque
mm	Nm	Nm	Nm	Nm	Nm
900	8400	14000	19600	28000	33600
1250	12600	21000	29400	42000	50400
1600	16800	28000	39200	56000	67200
2000	21600	36000	50400	72000	86400
3000	33600	56000	91800	112000	134400
3500	39600	66000	108200	132000	158400
4000	45600	76000	124600	152000	182400
Clamping force	30 kN	50 kN	70 kN	100 kN	120 kN
Oil pressure	min. 50 bar max. 200 bar	min. 80 bar max. 200 bar	min. 110 bar max. 200 bar	min. 140 bar max. 200 bar	min. 180 bar max. 200 bar
Oil volume	max. 160 cm ³	max. 160 cm ³	max. 160 cm ³	max. 160 cm ³	max. 160 cm ³
Weight	ca. 200 kg	ca. 200 kg	ca. 200 kg	ca. 200 kg	ca. 200 kg

The braking torques shown in the table are based on a theoretical friction coefficient of 0.4.

Brake Caliper HS 120 FHM

RINGSPANN®

spring activated – hydraulically released
for wind turbines or conveyor systems

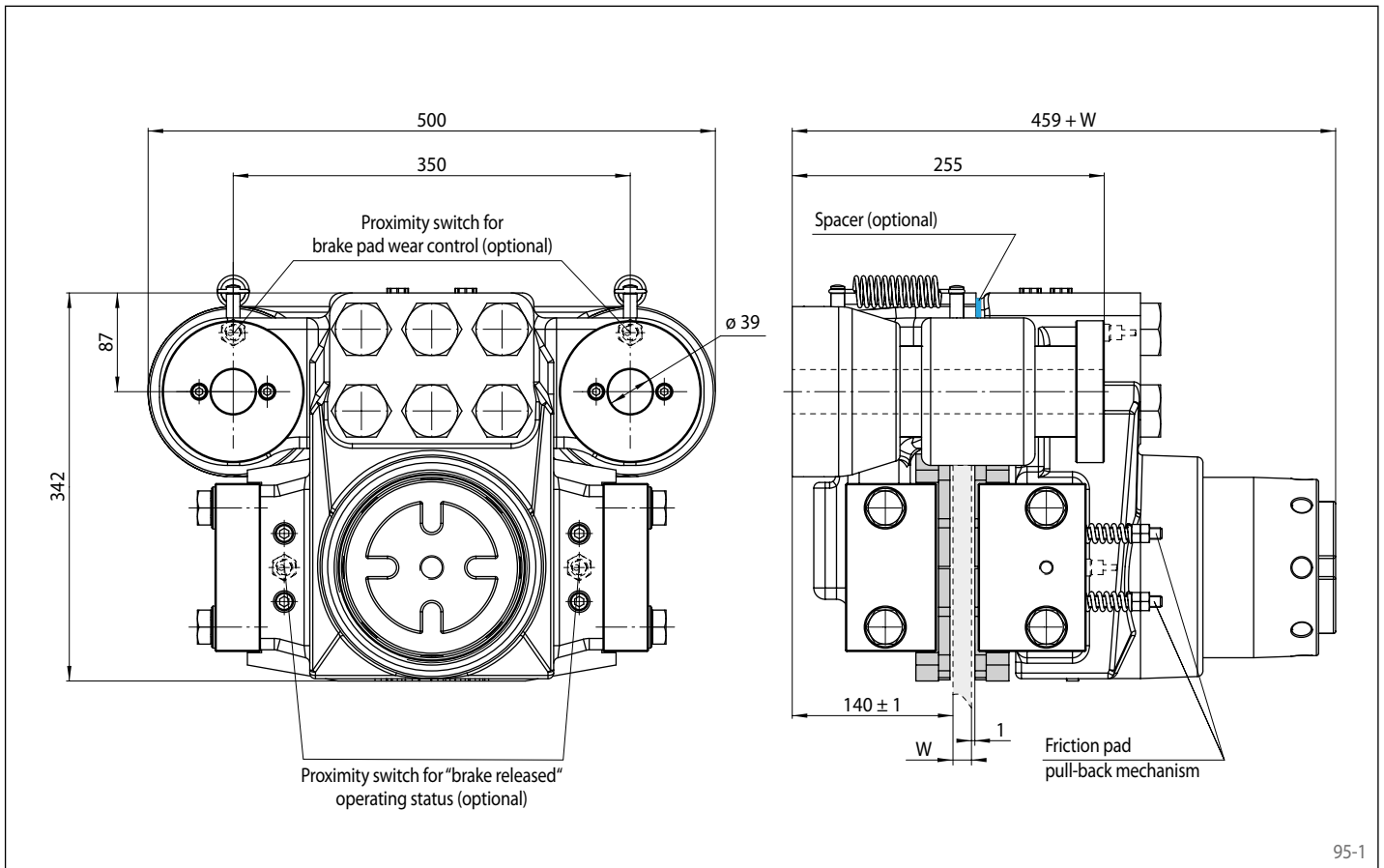

95-1

Mounting

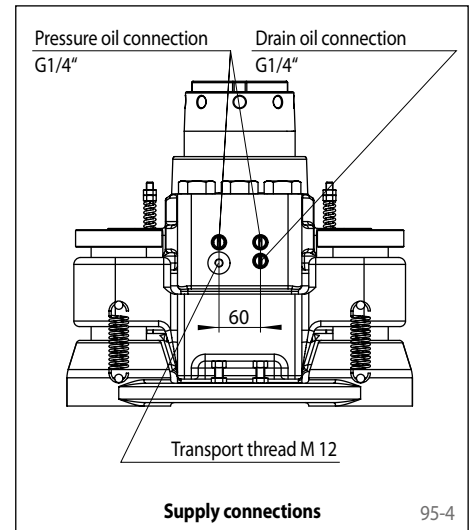
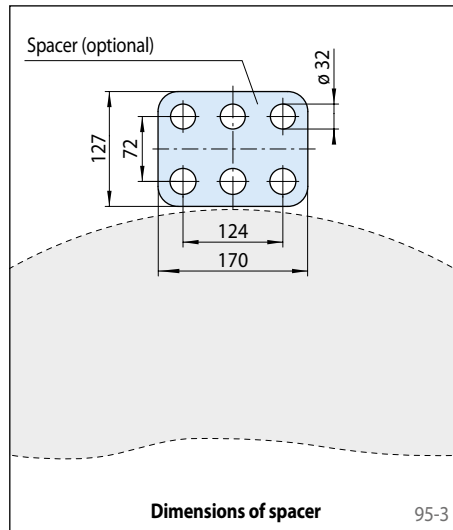
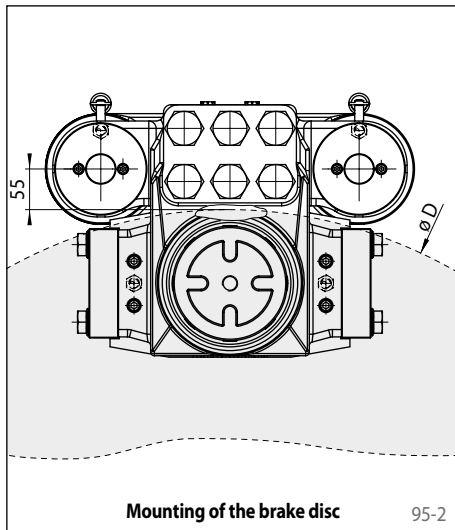

Other features

- High safety against leakage
- Easy change of friction blocks
- Painted with surface coating class C4-L according to ISO 12944
- For brake disc thickness $W = 20$ mm; brake disc thicknesses of up to 40 mm can be achieved with the use of a spacer installed by the customer

Accessories

- Inductive proximity switch for "brake released" operating status
- Inductive proximity switch for brake pad wear control
- Optional painting with surface coating class C4-H or C5M-H (offshore) according to ISO 12944

Brake Caliper HW 120 FHM

spring activated – hydraulically released

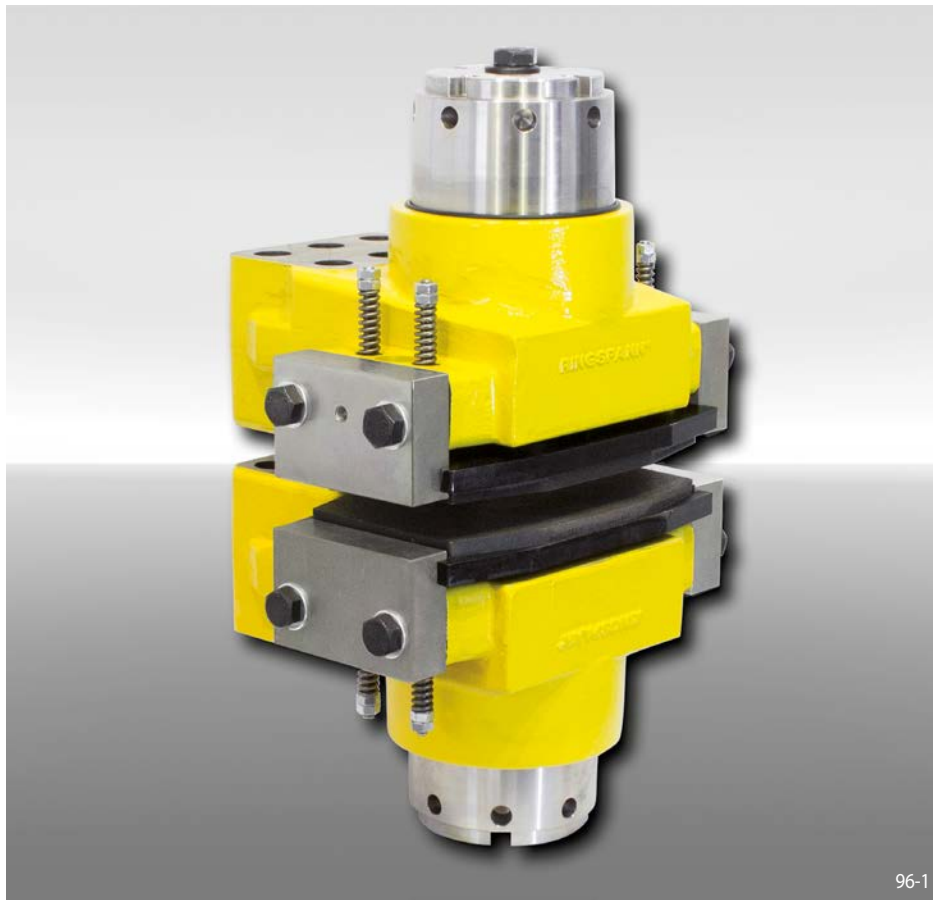

Features	Code
Brake Caliper	H
Standard	W
Frame size 120	120
Spring activated	F
Hydraulically released	H
Manual adjustment to accommodate friction block wear	M
Spring packages available for clamping forces of 30 kN, 50 kN, 70 kN, 100 kN or 120 kN	030 to 120

Example for ordering

Brake Caliper HW 120 FHM, spring package for clamping force 30 kN:

HW 120 FHM - 030

Technical Data

	Brake Caliper HW 120 FHM				
	with spring package 030	with spring package 050	with spring package 070	with spring package 100	with spring package 120
Brake disc diameter	Braking torque	Braking torque	Braking torque	Braking torque	Braking torque
mm	Nm	Nm	Nm	Nm	Nm
900	8400	14000	19600	28000	33600
1250	12600	21000	29400	42000	50400
1600	16800	28000	39200	56000	67200
2000	21600	36000	50400	72000	86400
3000	33600	56000	91800	112000	134400
3500	39600	66000	108200	132000	158400
4000	45600	76000	124600	152000	182400
Clamping force	30 kN	50 kN	70 kN	100 kN	120 kN
Oil pressure	min. 50 bar max. 200 bar	min. 80 bar max. 200 bar	min. 110 bar max. 200 bar	min. 140 bar max. 200 bar	min. 180 bar max. 200 bar
Oil volume	max. 170 cm ³	max. 170 cm ³	max. 170 cm ³	max. 170 cm ³	max. 170 cm ³
Weight	ca. 185 kg	ca. 185 kg	ca. 185 kg	ca. 185 kg	ca. 185 kg

The braking torques shown in the table are based on a theoretical friction coefficient of 0.4.

Brake Caliper HW 120 FHM

spring activated – hydraulically released

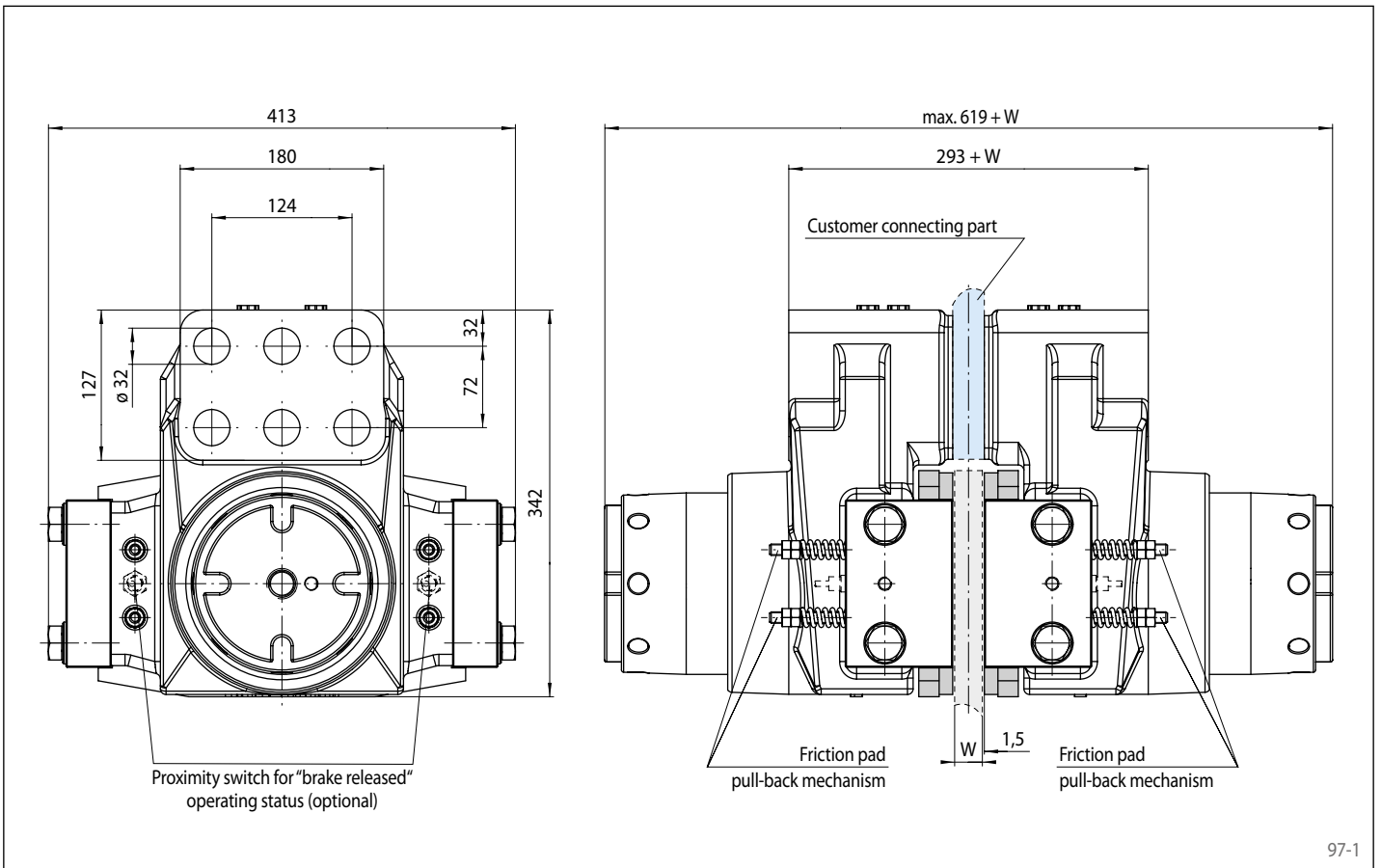

97-1

Mounting

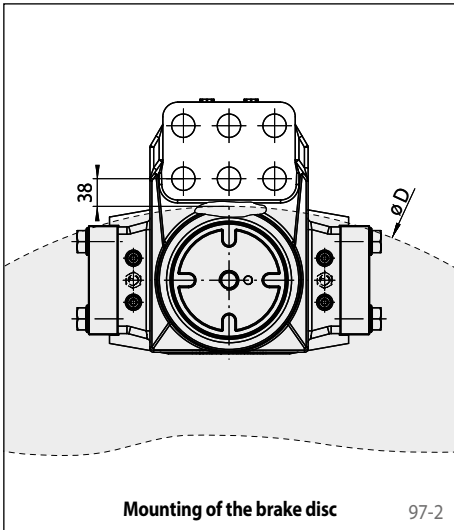

Mounting of the brake disc

97-2

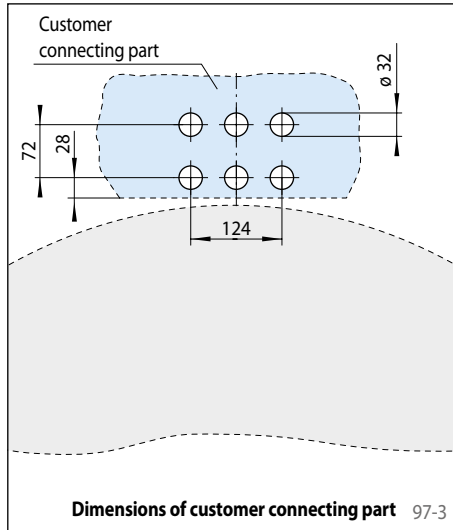

Dimensions of customer connecting part

97-3

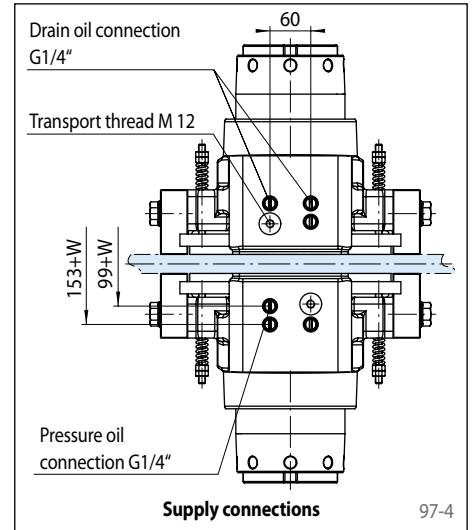

Supply connections

97-4

Other features

- High safety against leakage
- Easy change of friction blocks
- Painted with surface coating class C4-L according to ISO 12944
- The thickness of the customer connecting part results from the thickness of the brake disc W plus 3 mm

Accessories

- Inductive proximity switch for "brake released" operating status
- Optional painting with surface coating class C4-H or C5M-H (offshore) according to ISO 12944

Brake Caliper HS 145 FHM-270 R-V

spring activated – hydraulically released

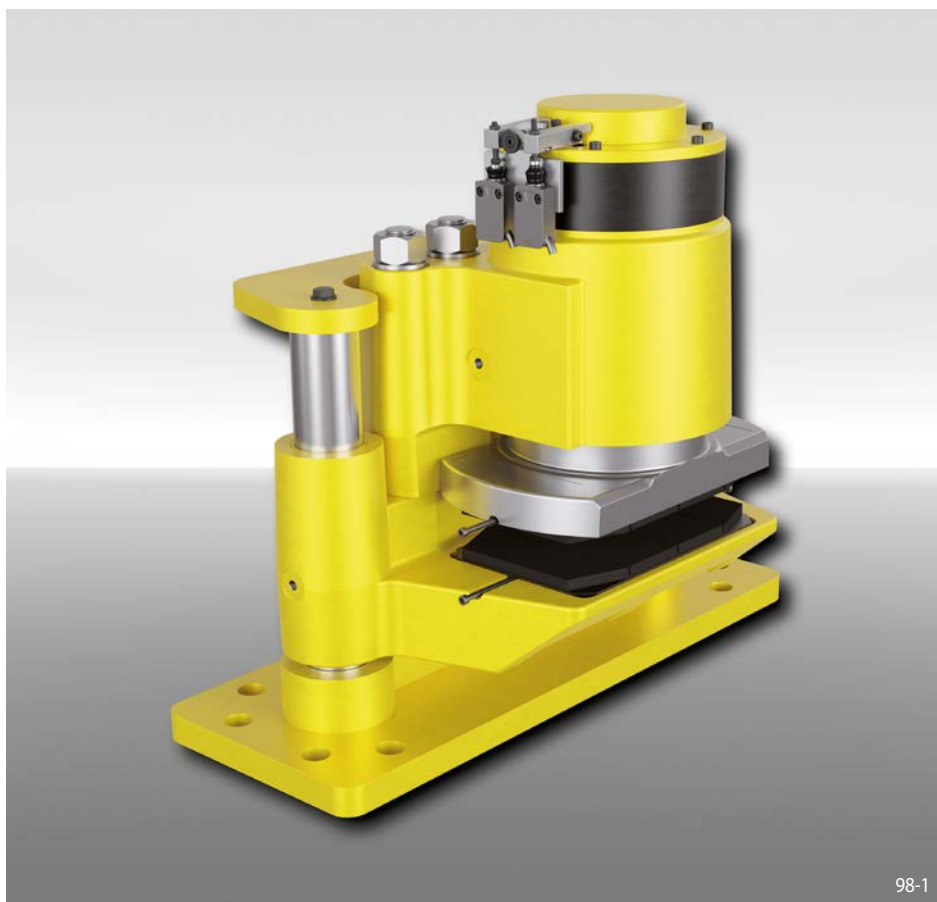

Features	Code
Brake Caliper	H
Floating caliper	S
Frame size 145	145
Spring activated	F
Hydraulically released	H
Manual adjustment to accommodate friction block wear	M
Max. clamping force 270 kN	270
Thruster mounted right available	R
Mounting to the machine parallel to the brake disc	V

Example for ordering

Brake Caliper HS 145 FHM, max. clamping force 270 kN, thruster mounted right, mounting to the machine parallel to the brake disc:

HS 145 FHM-270 R-V

Technical Data

Brake disc diameter	Braking torque
mm	Nm
700	54 900
800	65 400
1 000	86 600
1 250	112 900
1 600	149 900
2 000	192 100
3 000	297 700
3 500	350 400
4 000	403 200
Clamping force	270 kN
Oil pressure	min. 230 bar max. 250 bar
Oil volume	max. 40 cm ³
Thickness of brake disc W	30 mm
Weight	330 kg

The braking torques shown in the table are based on a theoretical friction coefficient of 0,4.

Working conditions

- Ambient temperature: -20 °C / +60 °C
- Air humidity: <90%

Monitoring switch

- 240 VAC 1.5 A; 250 VDC 0.1 A
- Cable 5 x 0.75 mm², length 2 m, outer diameter 7.5 mm
- Protection type IP67

Options

- Hydraulic Power Unit
- Friction pads with wear indicator cables or sintered friction linings (for high temperatures)
- Corrosion-protected version
- Low temperature version
- Offshore certifications
- ATEX certifications for hazardous areas

Notes

- Eyebolts included
- Fastening: 8 screws M 24, class 8.8 with tightening torque 630 Nm ±10% μ 0.15 (not supplied)

Brake Caliper HS 145 FHM-270 R-V

spring activated – hydraulically released

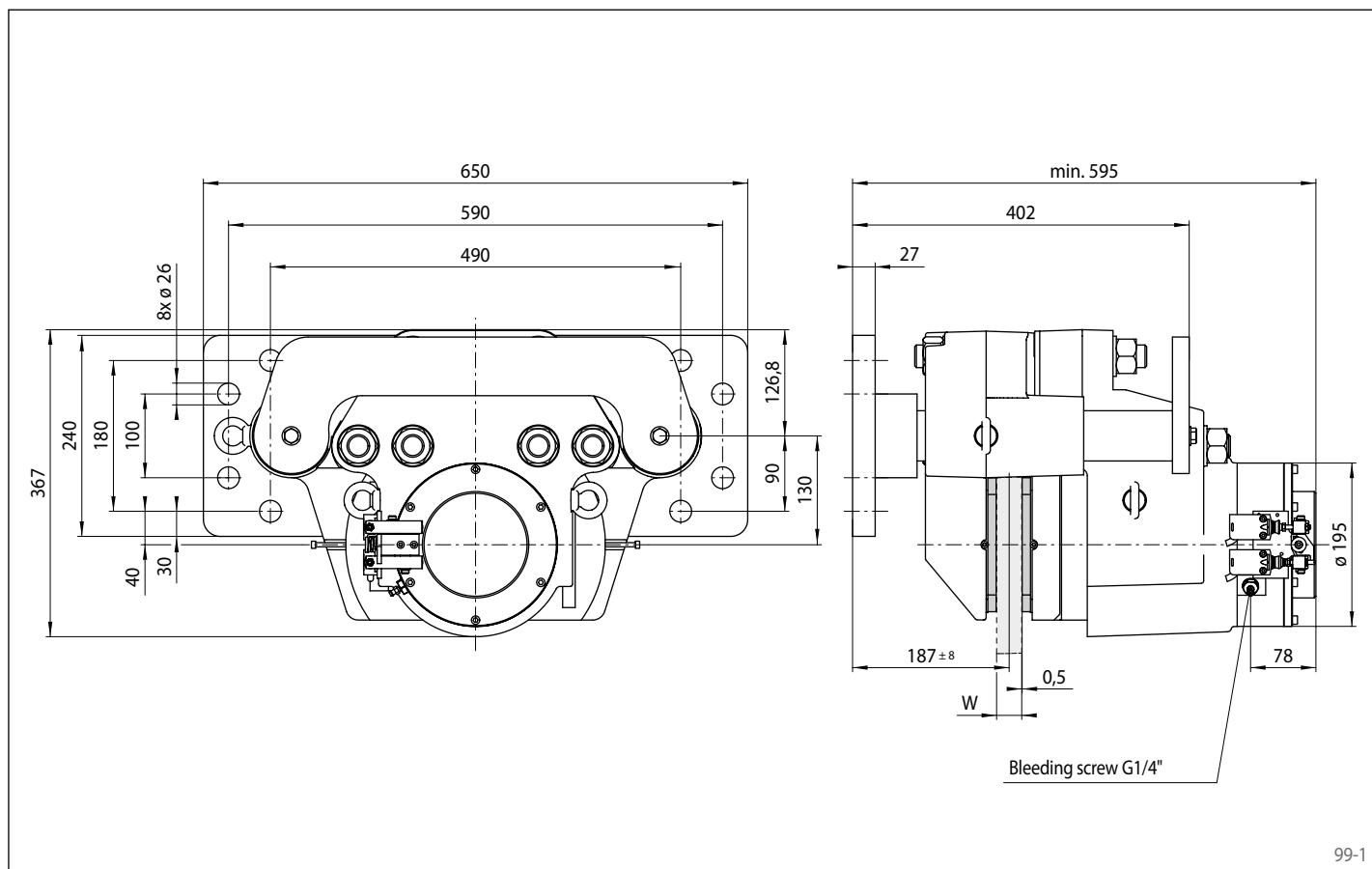

99-1

Mounting

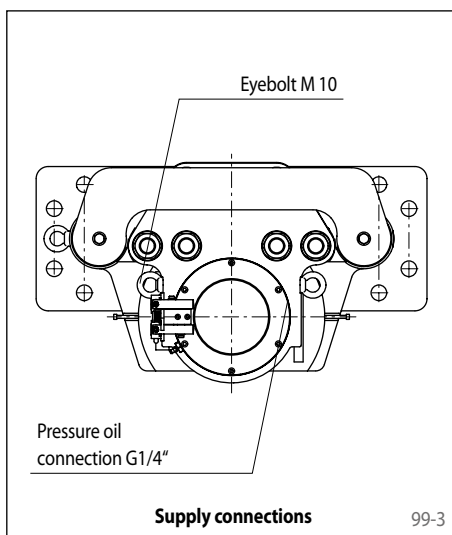
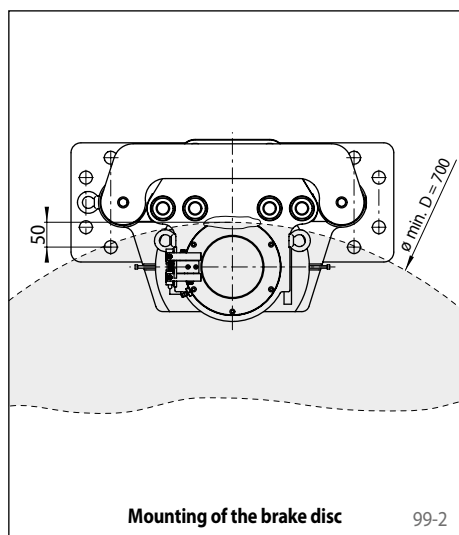

Brake Caliper HS 145 FHM-270 ... -H

spring activated – hydraulically released

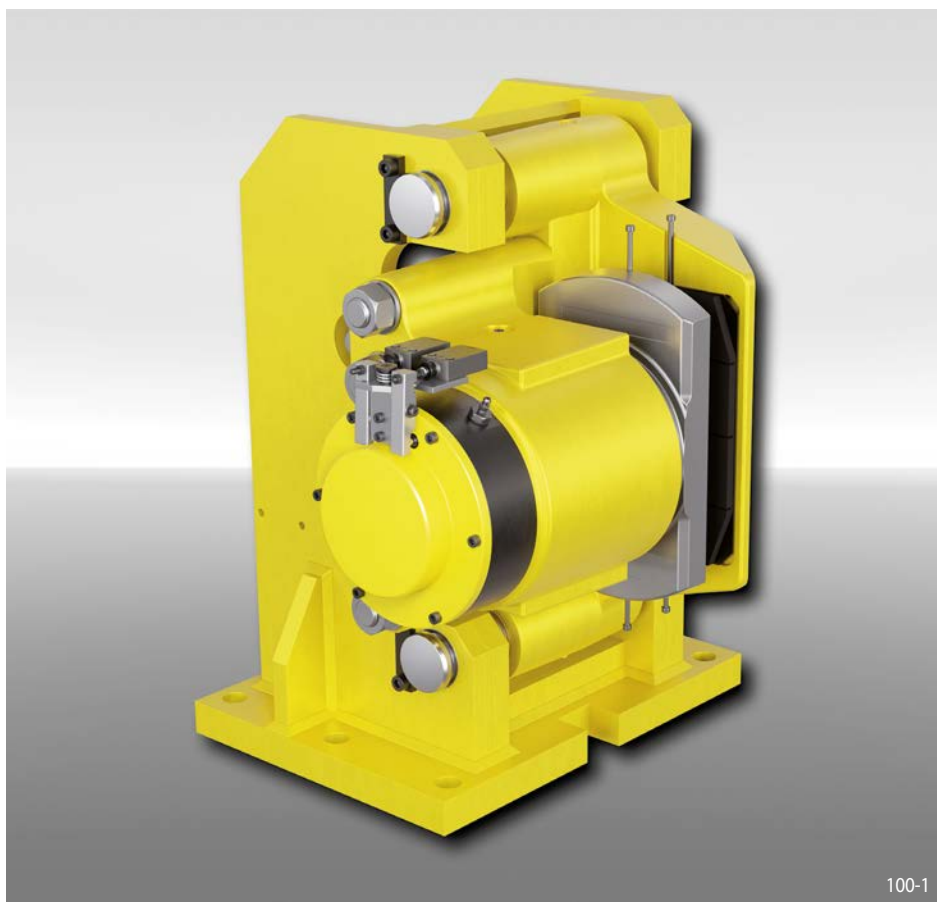

Features	Code
Brake Caliper	H
Floating caliper	S
Frame size 145	145
Spring activated	F
Hydraulically released	H
Manual adjustment to accommodate friction block wear	M
Max. clamping force 270 kN	270
Thruster mounted right or left available	R L
Mounting to the machine at right angles to the brake disc	H

Example for ordering

Brake Caliper HS 145 FHM, max. clamping force 270 kN, thruster mounted left, mounting to the machine at right angles to the brake disc:

HS 145 FHM-270 L-H

Technical Data

Brake disc diameter mm	Braking torque Nm
700	54 900
800	65 400
1 000	86 600
1 250	112 900
1 600	149 900
2 000	192 100
3 000	297 700
3 500	350 400
4 000	403 200
Clamping force	270 kN
Oil pressure	min. 230 bar max. 250 bar
Oil volume	max. 40 cm ³
Thickness of brake disc W	30 mm
Weight	330 kg

The braking torques shown in the table are based on a theoretical friction coefficient of 0,4.

Working conditions

- Ambient temperature: -20 °C / +60 °C
- Air humidity: <90%

Monitoring switch

- 240 VAC 1.5 A; 250 VDC 0.1 A
- Cable 5 x 0.75 mm², length 2 m, outer diameter 7.5 mm
- Protection type IP67

Options

- Integrated Hydraulic Power Unit
- Friction pads with wear indicator cables or sintered friction linings (for high temperatures)
- Corrosion-protected version
- Low temperature version
- Offshore certifications
- ATEX certifications for hazardous areas

Notes

- Eyebolts included
- Fastening:
6 screws M 24, class 8.8 with tightening torque 630 Nm ±10% μ 0.15 (not supplied)

Brake Caliper HS 145 FHM-270 ... -H

spring activated – hydraulically released

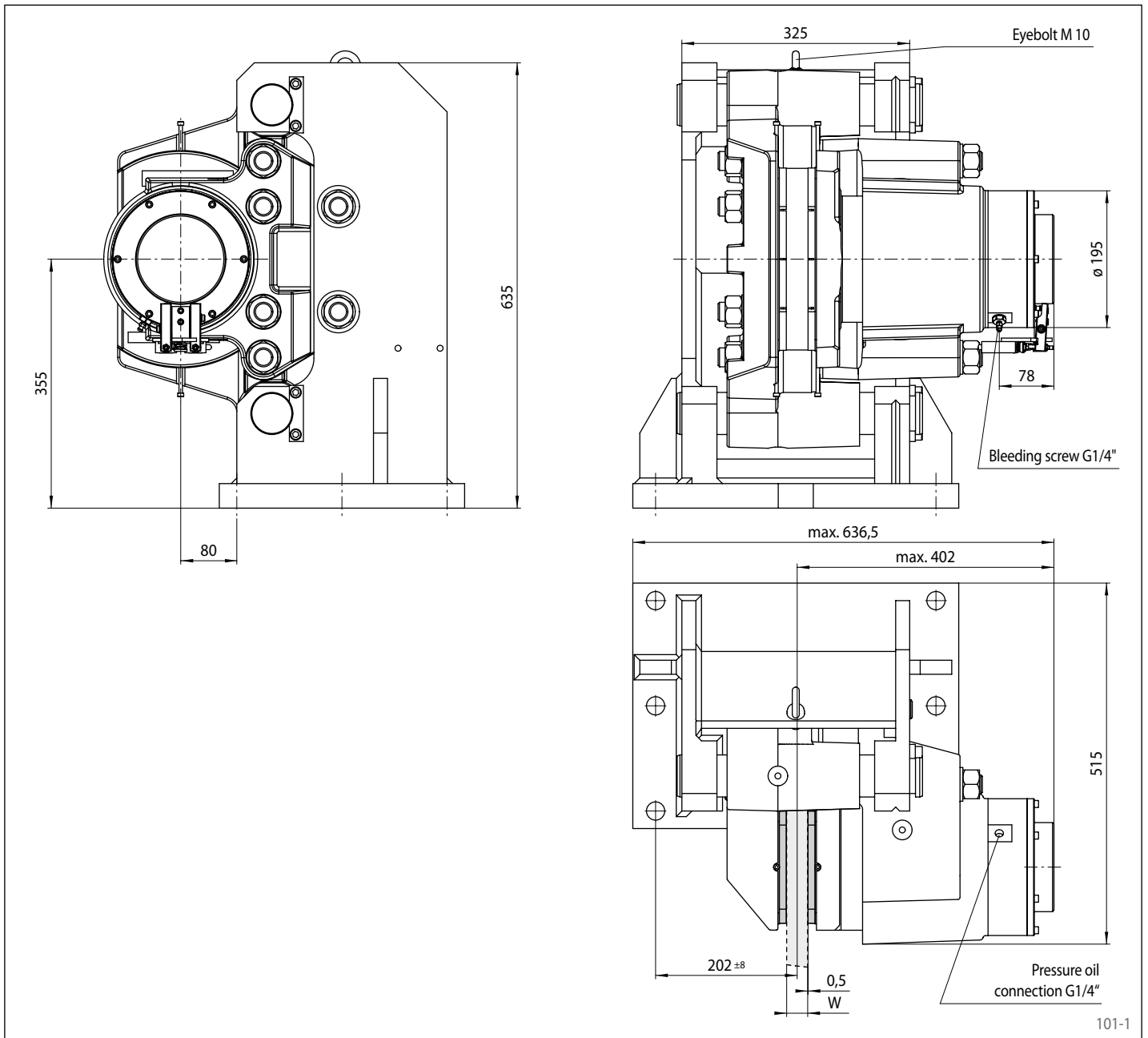

101-1

Mounting

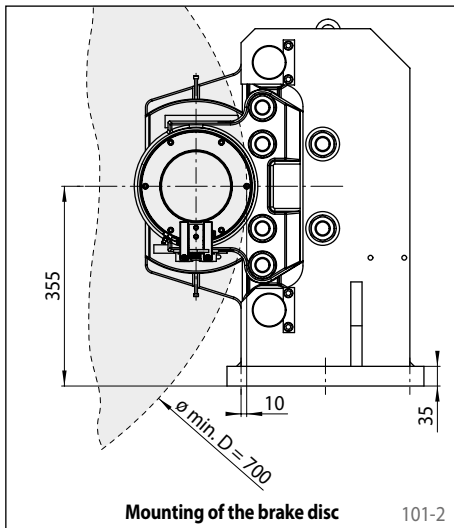

Mounting of the brake disc

101-2

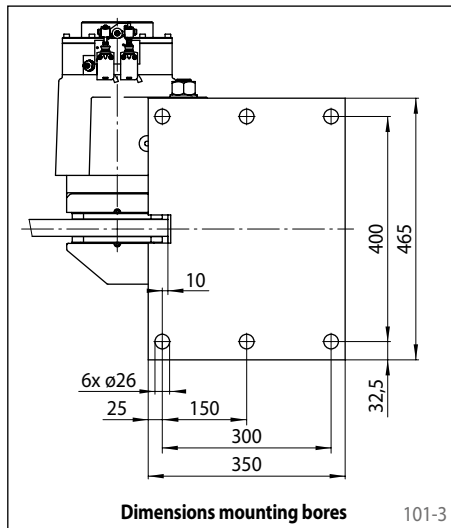

Dimensions mounting bores

101-3

Brake Caliper HW 145 FHM

spring activated – hydraulically released



Features	Code
Brake Caliper	H
Standard	W
Frame size 145	145
Spring activated	F
Hydraulically released	H
Manual adjustment to accommodate friction block wear	M
Max. clamping force 270 kN	270

Example for ordering

Brake Caliper HW 145 FHM, max. clamping force 270 kN:

HW 145 FHM-270

Technical Data

Brake disc diameter mm	Braking torque Nm
700	54 900
800	65 400
1 000	86 600
1 250	112 900
1 600	149 900
2 000	192 100
3 000	297 700
3 500	350 400
4 000	403 200
Clamping force	270 kN
Oil pressure	min. 230 bar max. 250 bar
Oil volume	max. 70 cm ³
Thickness of brake disc W	min. 25 mm
Weight	237 kg

The braking torques shown in the table are based on a theoretical friction coefficient of 0,4.

Working conditions

- Ambient temperature: -20 °C / +60 °C
- Air humidity: <90%

Monitoring switch

- 240 VAC 1.5 A; 250 VDC 0.1 A
- Cable 5 x 0.75 mm², length 2 m, outer diameter 7.5 mm
- Protection type IP67

Options

- Friction pads with wear indicator cables or sintered friction linings (for high temperatures)
- Corrosion-protected version
- Low temperature version
- Offshore certifications
- ATEX certifications for hazardous areas

Notes

- Includes two pairs of ø 32_{g6} shear pins
- Eyebolts included
- Fastening:
6 screws M 27, class 10.9 with tightening torque 1 380 Nm ±10% μ 0.15 (not supplied)

Brake Caliper HW 145 FHM

spring activated – hydraulically released

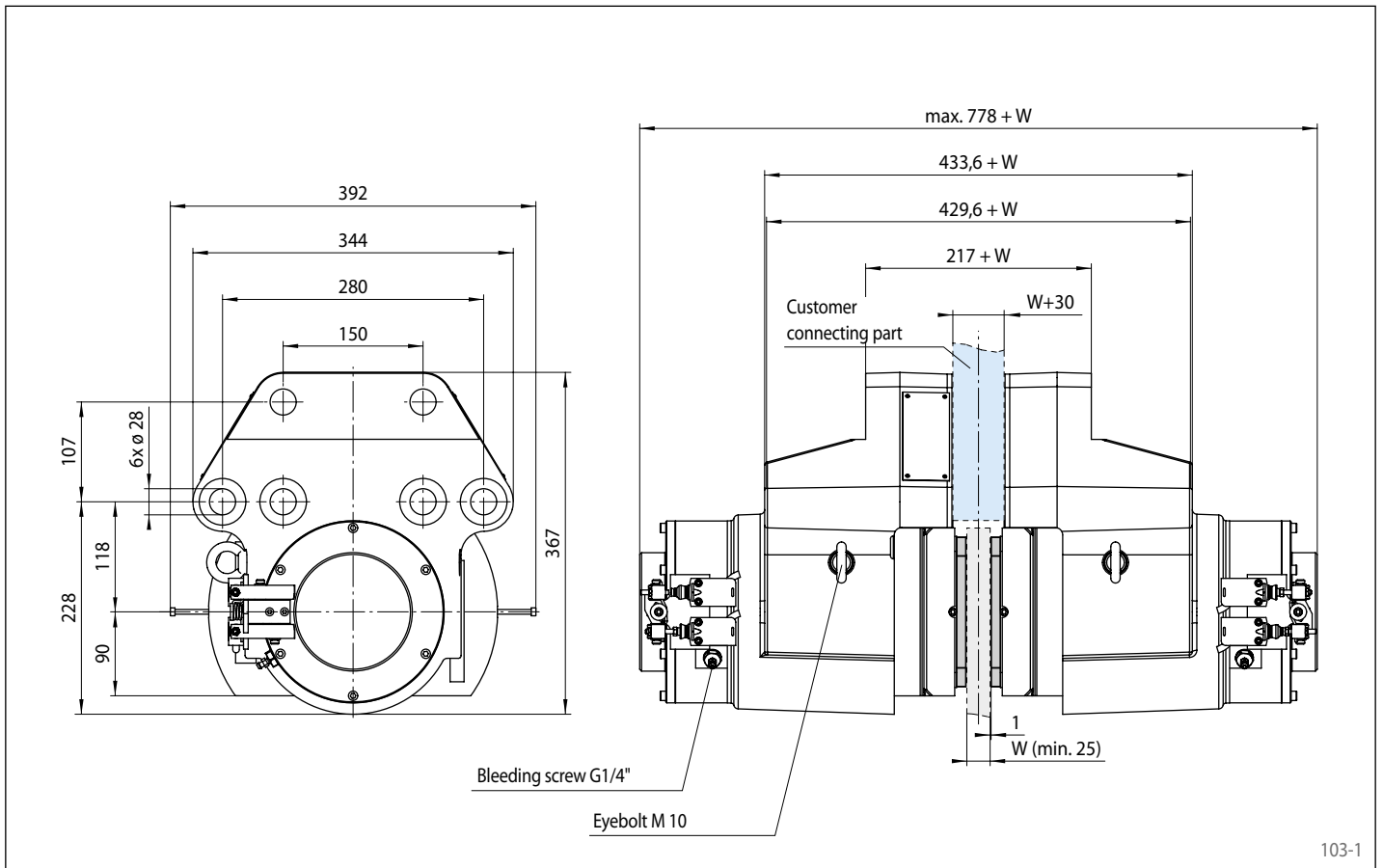

103-1

Mounting

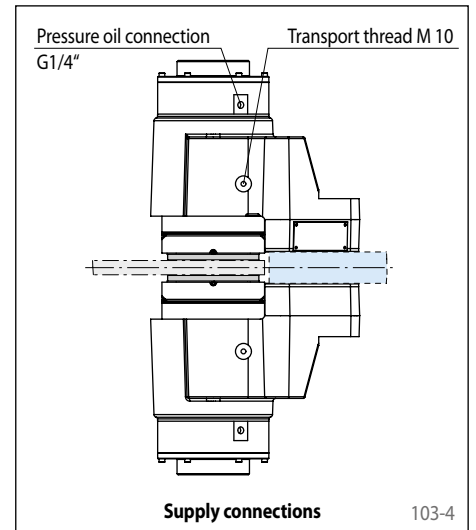
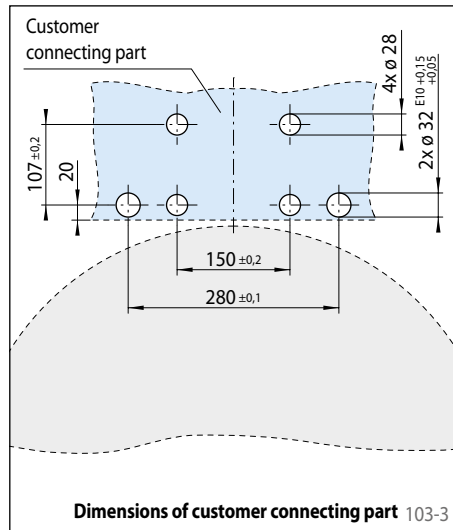
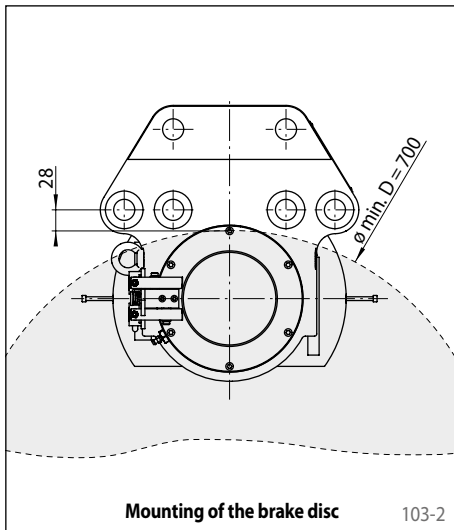

Brake Caliper HS 165 FHM-420 R-V

spring activated – hydraulically released

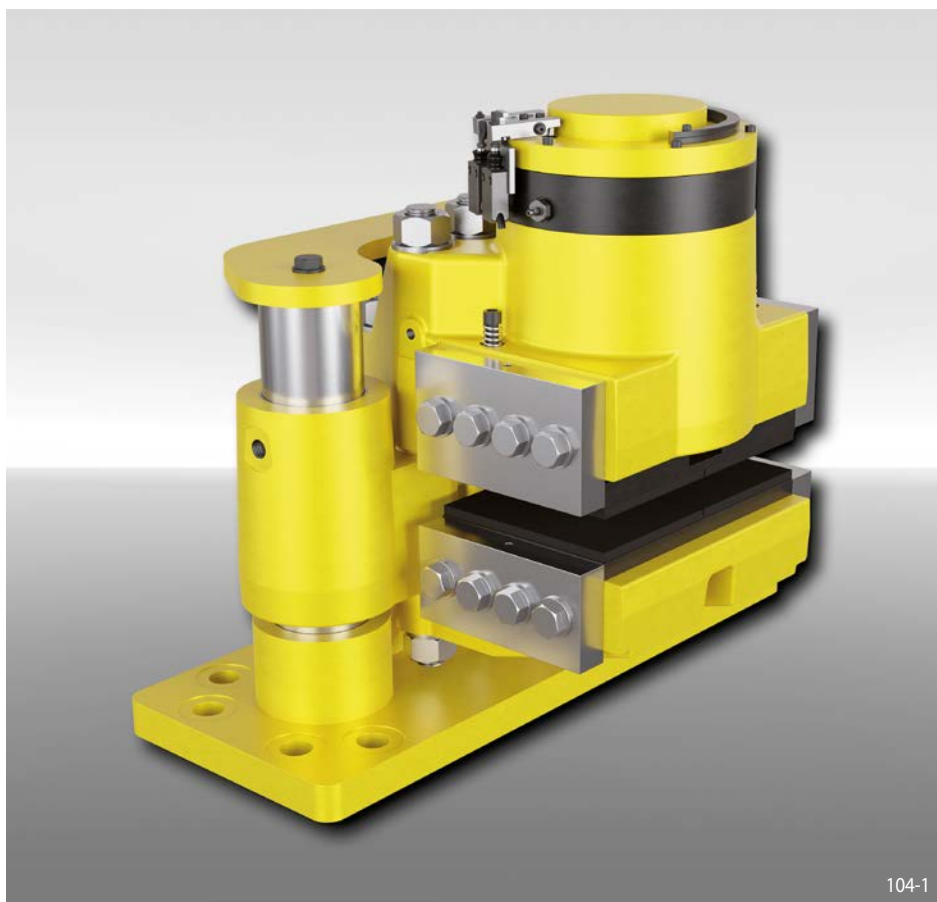

Features	Code
Brake Caliper	H
Floating caliper	S
Frame size 165	165
Spring activated	F
Hydraulically released	H
Manual adjustment to accommodate friction block wear	M
Max. clamping force 420 kN	420
Thruster mounted right available	R
Mounting to the machine parallel to the brake disc	V

Example for ordering

Brake Caliper HS 165 FHM, max. clamping force 420 kN, thruster mounted right, mounting to the machine parallel to the brake disc:

HS 165 FHM-420 R-V

Technical Data

Brake disc diameter mm	Braking torque Nm
800	97 700
1 000	131 000
1 250	172 700
1 600	231 000
2 000	297 700
3 000	464 300
3 500	547 700
4 000	631 000
Clamping force	420 kN
Oil pressure	min. 230 bar max. 250 bar
Oil volume	max. 70 cm ³
Thickness of brake disc W	30 mm
Weight	528 kg

The braking torques shown in the table are based on a theoretical friction coefficient of 0,4.

Working conditions

- Ambient temperature: -20 °C / +60 °C
- Air humidity: <90%

Monitoring switch

- 240 VAC 1.5 A; 250 VDC 0.1 A
- Cable 5 x 0.75 mm², length 2 m, outer diameter 7.5 mm
- Protection type IP67

Options

- Hydraulic Power Unit
- Friction pads with wear indicator cables or sintered friction linings (for high temperatures)
- Corrosion-protected version
- Low temperature version
- Offshore certifications
- ATEX certifications for hazardous areas

Notes

- Eyebolts included
- Fastening:
8 screws M 30, class 8.8 with tightening torque 1 200 Nm ±10% μ 0.15 (not supplied)

Brake Caliper HS 165 FHM-420 R-V

spring activated – hydraulically released

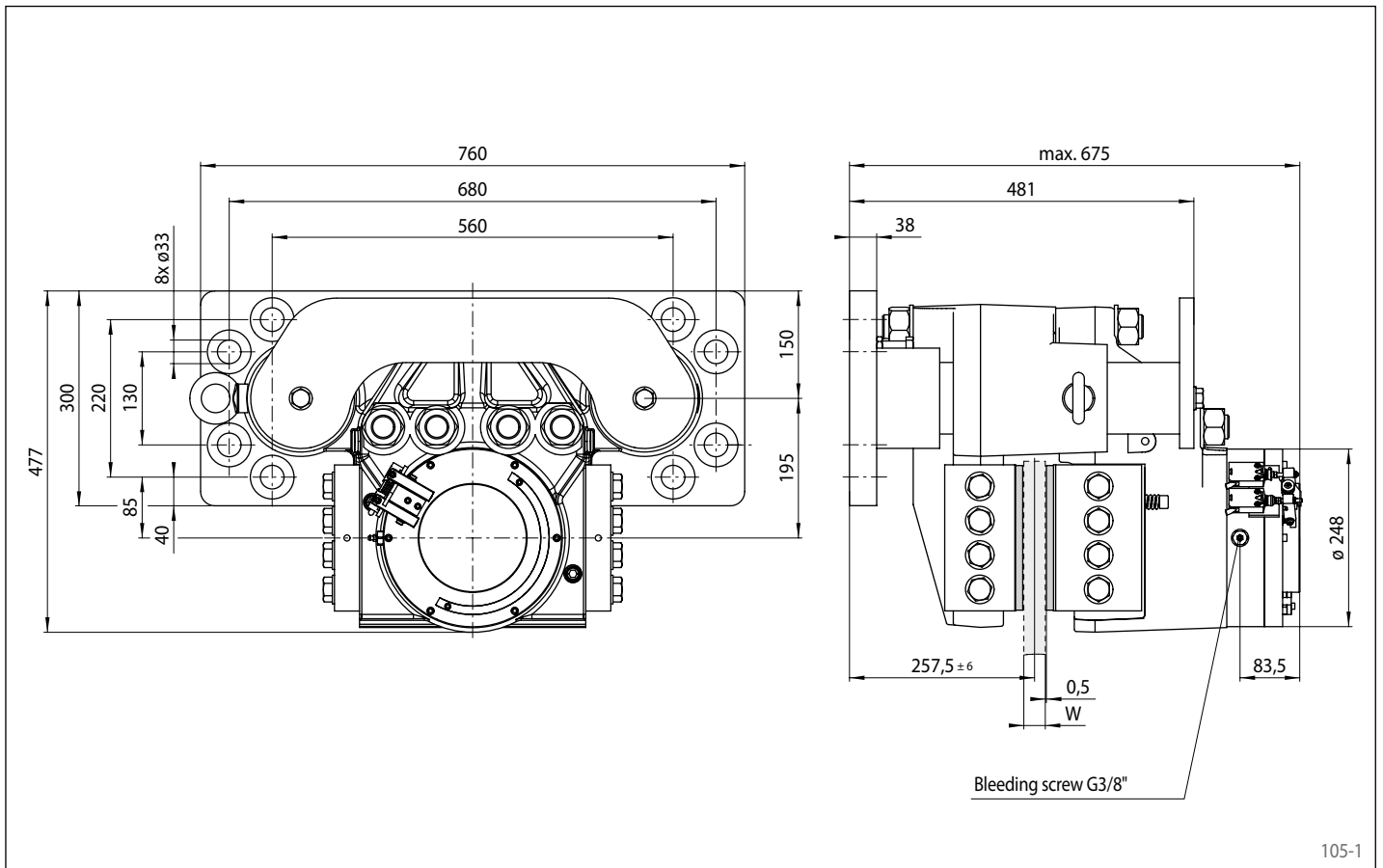

105-1

Mounting

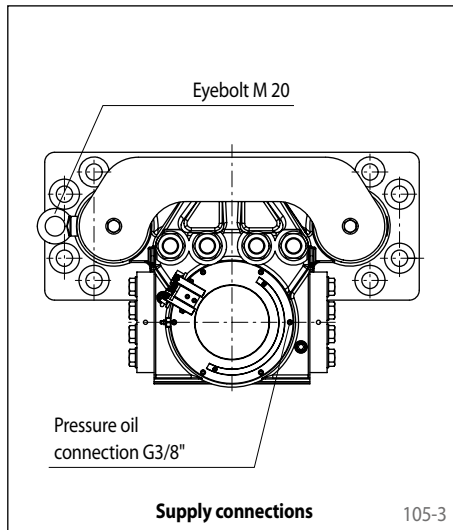
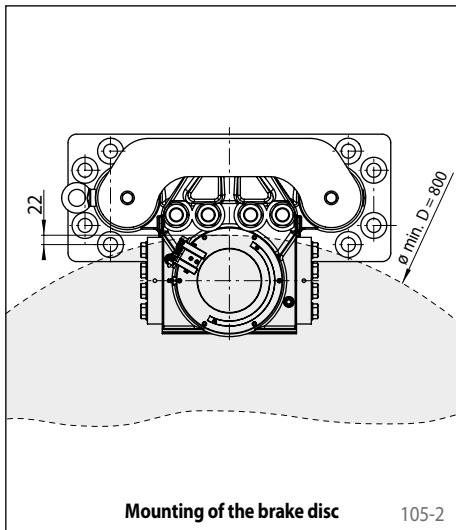

Brake Caliper HS 165 FHM-420 ... -H

spring activated – hydraulically released



Features	Code
Brake Caliper	H
Floating caliper	S
Frame size 165	165
Spring activated	F
Hydraulically released	H
Manual adjustment to accommodate friction block wear	M
Max. clamping force 420 kN	420
Thruster mounted right or left available	R L
Mounting to the machine at right angles to the brake disc	H

Example for ordering

Brake Caliper HS 165 FHM, max. clamping force 420 kN, thruster mounted left, mounting to the machine at right angles to the brake disc:

HS 165 FHM-420 L-H

Technical Data

Brake disc diameter mm	Braking torque Nm
800	97 700
1 000	131 000
1 250	172 700
1 600	231 000
2 000	297 700
3 000	464 300
3 500	547 700
4 000	631 000
Clamping force	420 kN
Oil pressure	min. 230 bar max. 250 bar
Oil volume	max. 70 cm ³
Thickness of brake disc W	30 mm
Weight	625 kg

The braking torques shown in the table are based on a theoretical friction coefficient of 0,4.

Working conditions

- Ambient temperature: -20 °C / +60 °C
- Air humidity: <90%

Monitoring switch

- 240 VAC 1.5 A; 250 VDC 0.1 A
- Cable 5 x 0.75 mm², length 2 m, outer diameter 7.5 mm
- Protection type IP67

Options

- Integrated Hydraulic Power Unit
- Friction pads with wear indicator cables or sintered friction linings (for high temperatures)
- Corrosion-protected version
- Low temperature version
- Offshore certifications
- ATEX certifications for hazardous areas

Notes

- Eyebolts included
- Fastening:
6 screws M 30, class 8.8 with tightening torque 1 200 Nm ±10% μ 0.15 (not supplied)

Brake Caliper HS 165 FHM-420 ... -H

spring activated – hydraulically released

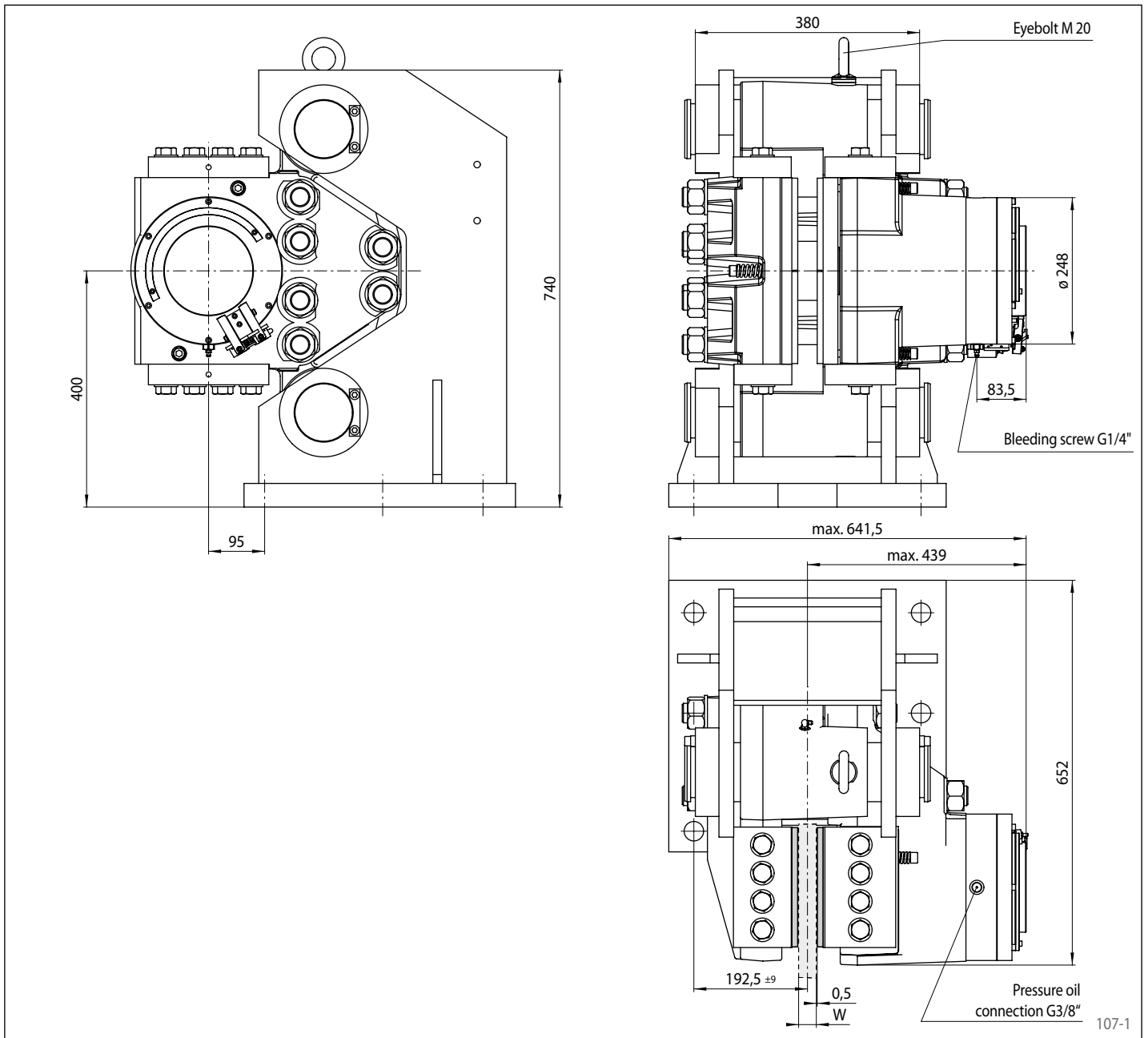

Mounting

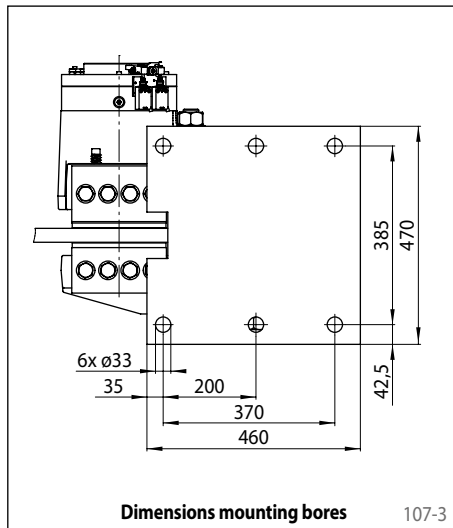
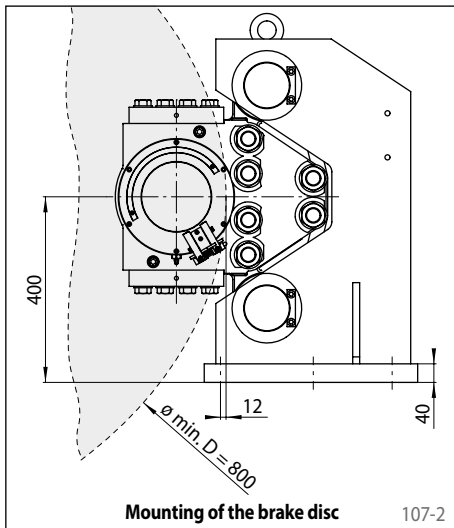

Brake Caliper HW 165 FHM

spring activated – hydraulically released

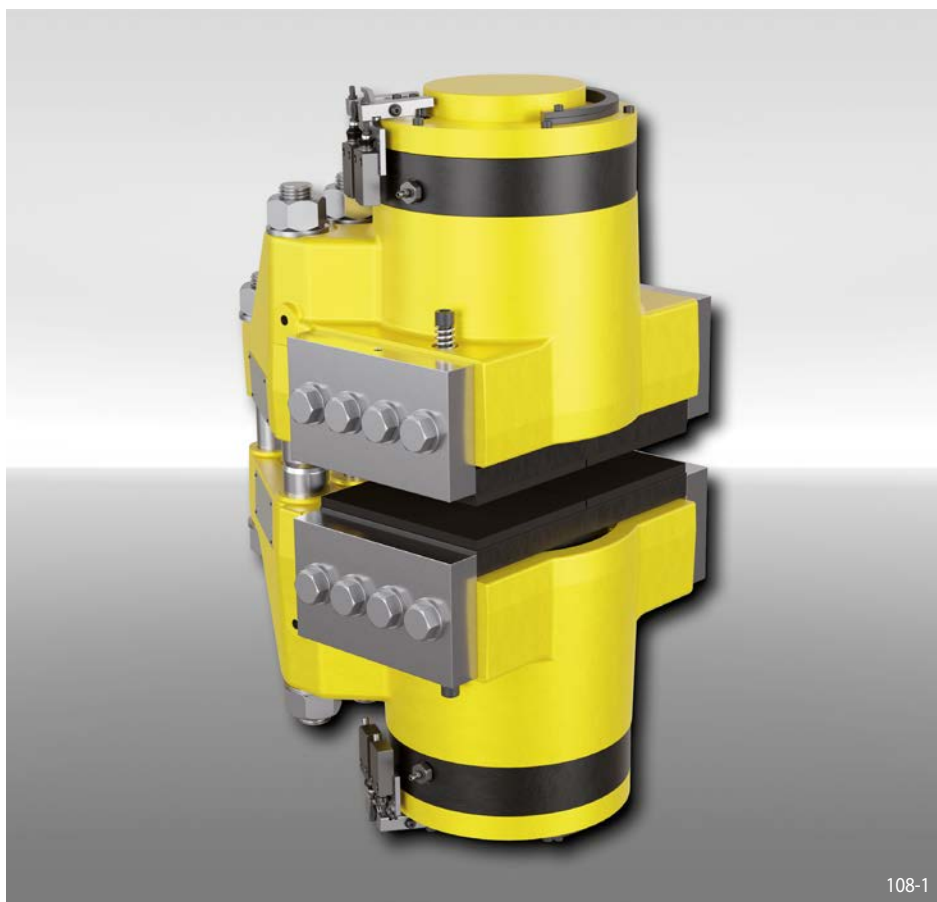

Features	Code
Brake Caliper	H
Standard	W
Frame size 165	165
Spring activated	F
Hydraulically released	H
Manual adjustment to accommodate friction block wear	M
Max. clamping force 420 kN	420

Example for ordering

Brake Caliper HW 165 FHM, max. clamping force 420 kN:

HW 165 FHM-420

Technical Data

Brake disc diameter mm	Braking torque Nm
800	97 700
1 000	131 000
1 250	172 700
1 600	231 000
2 000	297 700
3 000	464 300
3 500	547 700
4 000	631 000
Clamping force	420 kN
Oil pressure	min. 230 bar max. 250 bar
Oil volume	max. 120 cm ³
Thickness of brake disc W	min. 30 mm
Weight	425 kg

The braking torques shown in the table are based on a theoretical friction coefficient of 0,4.

Working conditions

- Ambient temperature: -20 °C / +60 °C
- Air humidity: <90%

Monitoring switch

- 240 VAC 1.5 A; 250 VDC 0.1 A
- Cable 5 x 0.75 mm², length 2 m, outer diameter 7.5 mm
- Protection type IP67

Options

- Friction pads with wear indicator cables or sintered friction linings (for high temperatures)
- Corrosion-protected version
- Low temperature version
- Offshore certifications
- ATEX certifications for hazardous areas

Notes

- Includes two pairs of $\varnothing 46_{g6}$ shear pins
- Eyebolts included
- Fastening:
6 screws M 33, , class 10.9 with tightening torque 1 950 Nm $\pm 5\%$ μ 0.10 (not supplied)

Brake Caliper HW 165 FHM

spring activated – hydraulically released

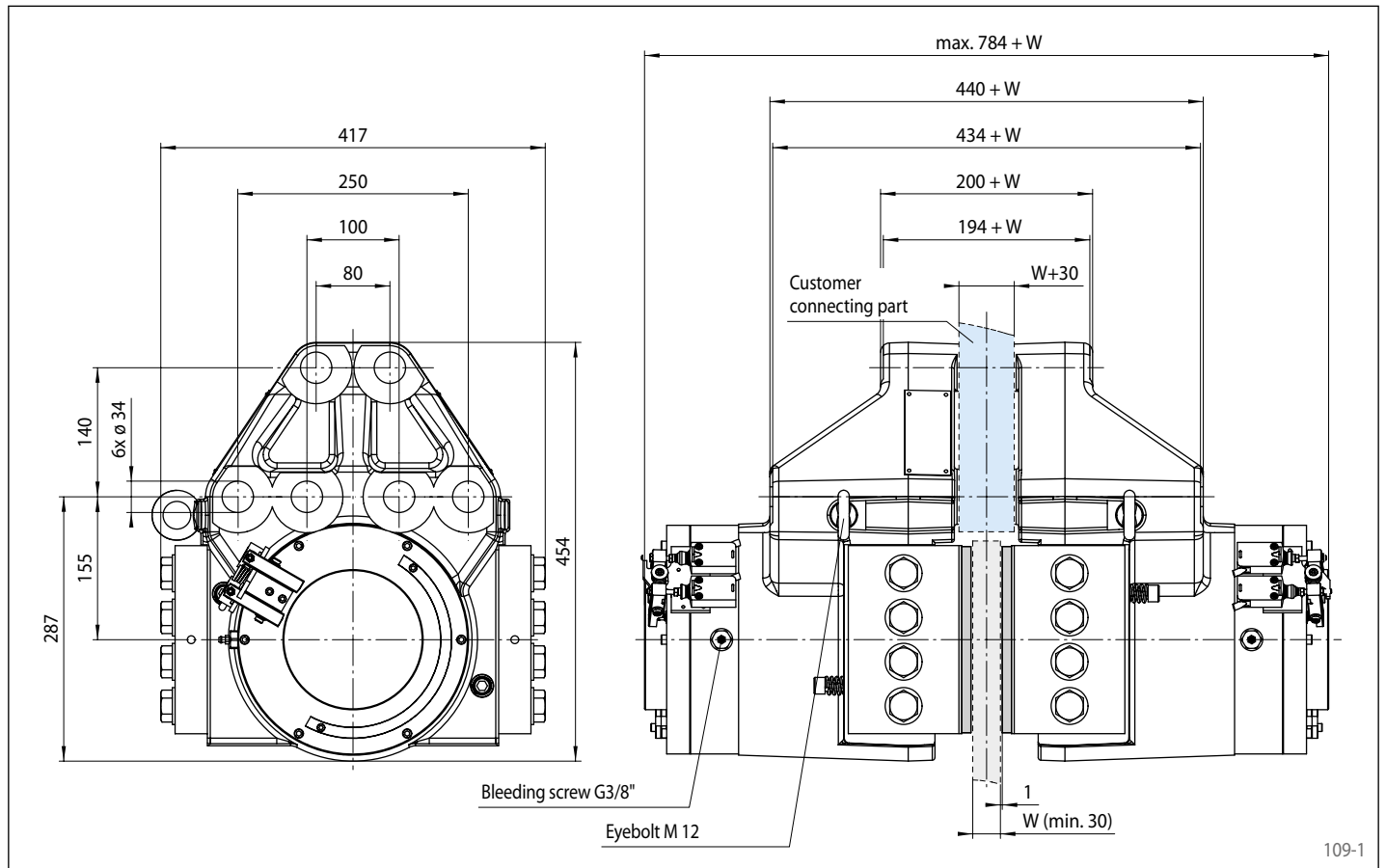

Mounting

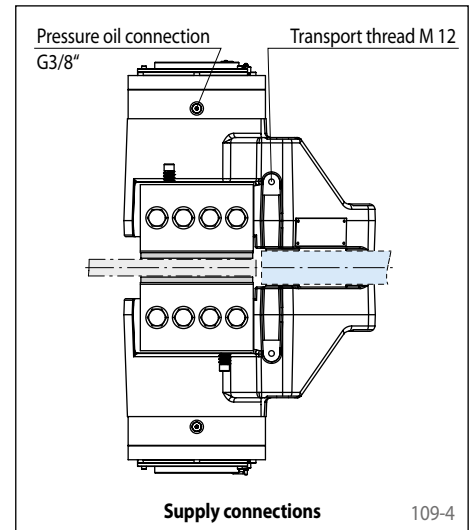
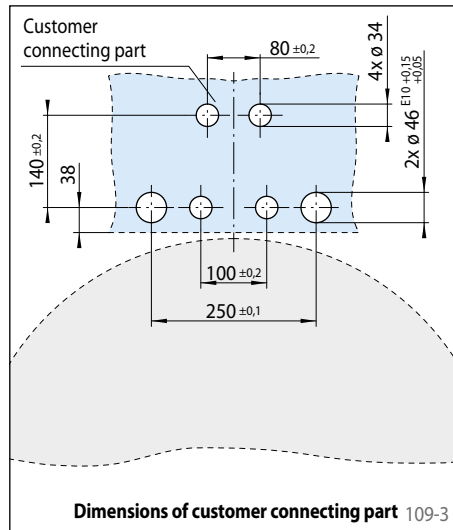
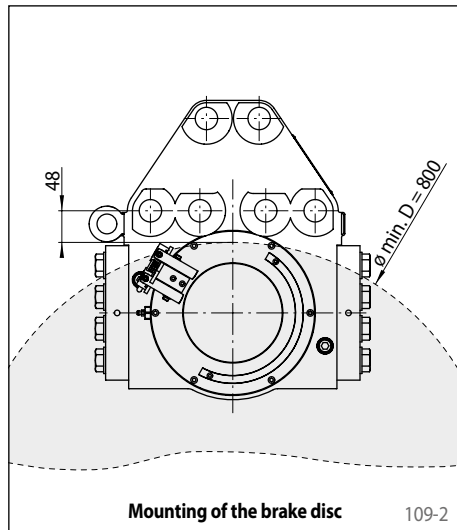

Brake Caliper HS 215 FHM-560 R-V

spring activated – hydraulically released

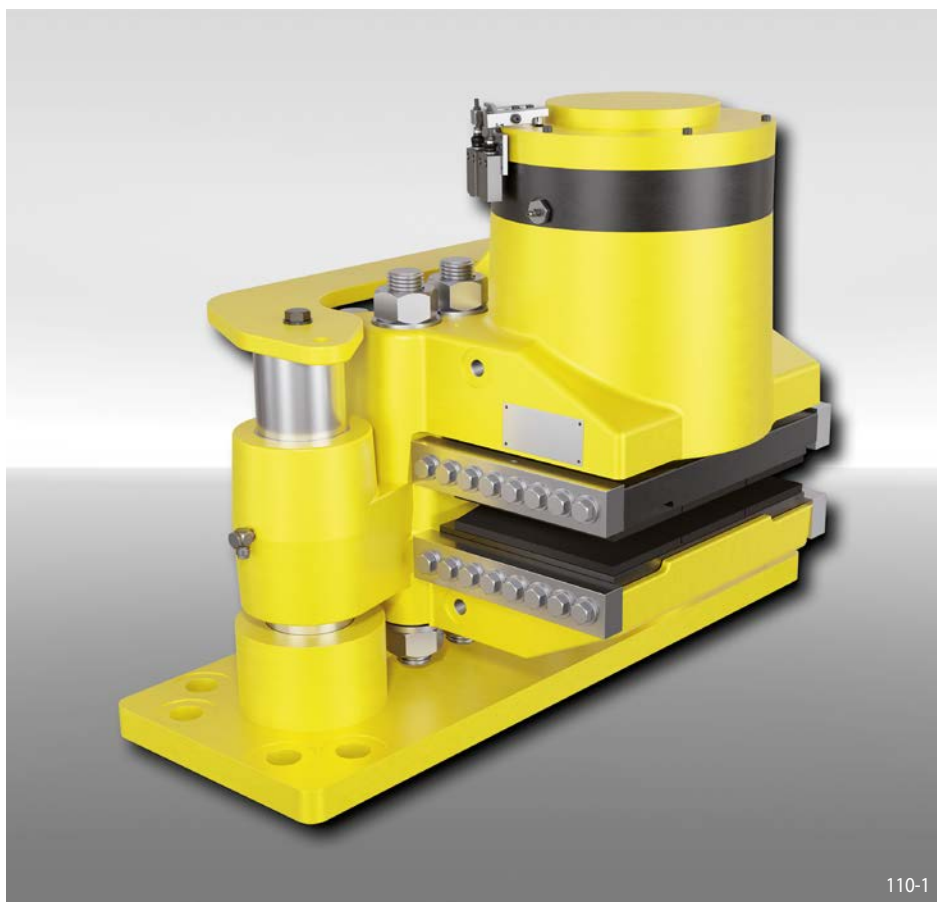

Features	Code
Brake Caliper	H
Floating caliper	S
Frame size 215	215
Spring activated	F
Hydraulically released	H
Manual adjustment to accommodate friction block wear	M
Max. clamping force 560 kN	560
Thruster mounted right available	R
Mounting to the machine parallel to the brake disc	V

Example for ordering

Brake Caliper HS 215 FHM, max. clamping force 560 kN, thruster mounted right, mounting to the machine parallel to the brake disc:

HS 215 FHM-560 R-V

Technical Data

Brake disc diameter mm	Braking torque Nm
1 000	164 400
1 250	220 000
1 600	297 800
2 000	386 700
3 000	608 900
3 500	720 000
4 000	831 100
Clamping force	560 kN
Oil pressure	min. 230 bar max. 250 bar
Oil volume	max. 150 cm ³
Thickness of brake disc W	30 mm
Weight	880 kg

The braking torques shown in the table are based on a theoretical friction coefficient of 0,4.

Working conditions

- Ambient temperature: -20 °C / +60 °C
- Air humidity: <90%

Monitoring switch

- 240 VAC 1.5 A; 250 VDC 0.1 A
- Cable 5 x 0.75 mm², length 2 m, outer diameter 7.5 mm
- Protection type IP67

Options

- Hydraulic Power Unit
- Friction pads with wear indicator cables or sintered friction linings (for high temperatures)
- Corrosion-protected version
- Low temperature version
- Offshore certifications
- ATEX certifications for hazardous areas

Notes

- Eyebolts included
- Fastening:
8 screws M 36, class 8.8 with tightening torque 2 200 Nm ±10% μ 0.15 (not supplied)

Brake Caliper HS 215 FHM-560 R-V

RINGSPANN®

spring activated – hydraulically released

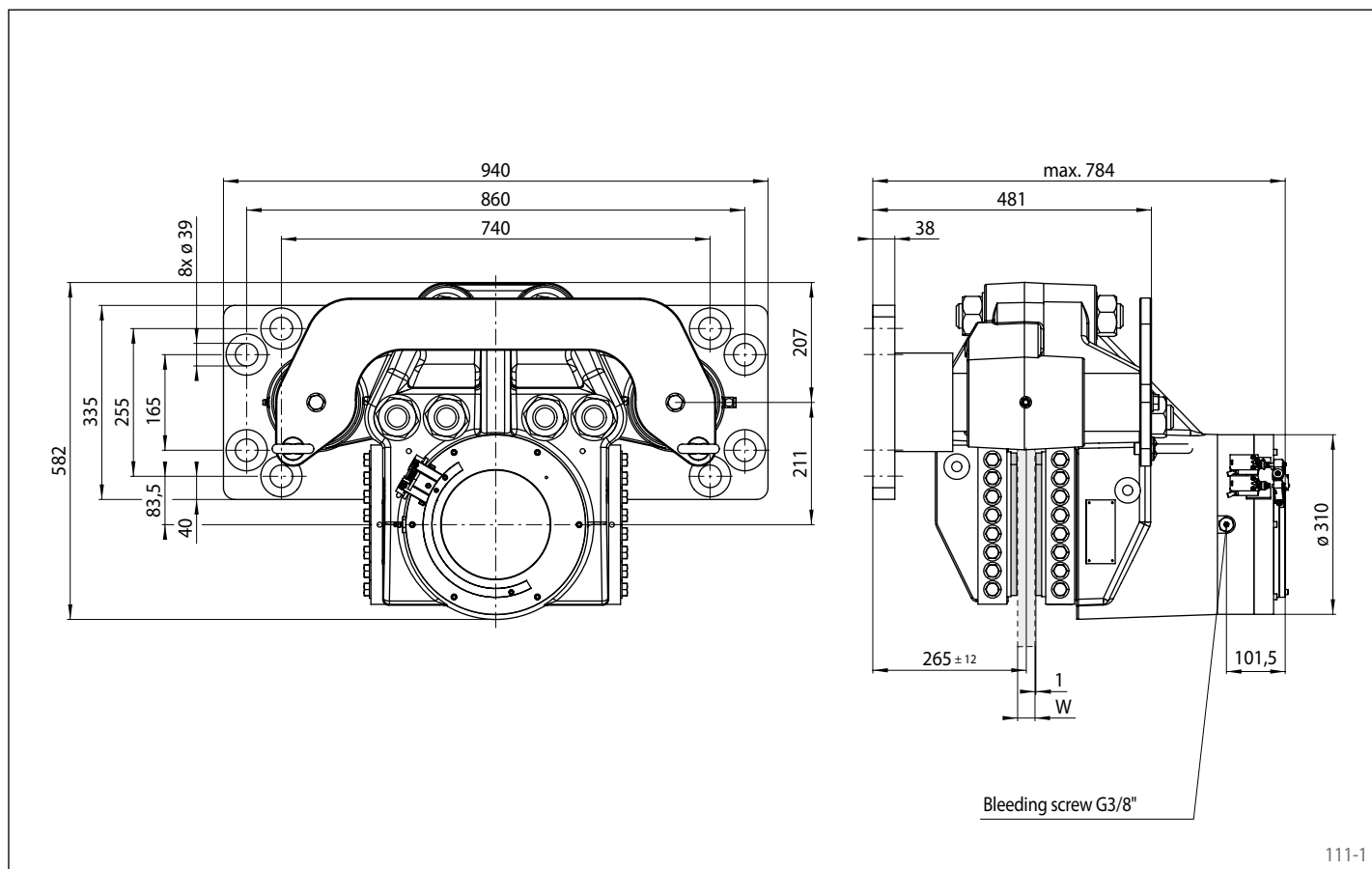

111-1

Mounting

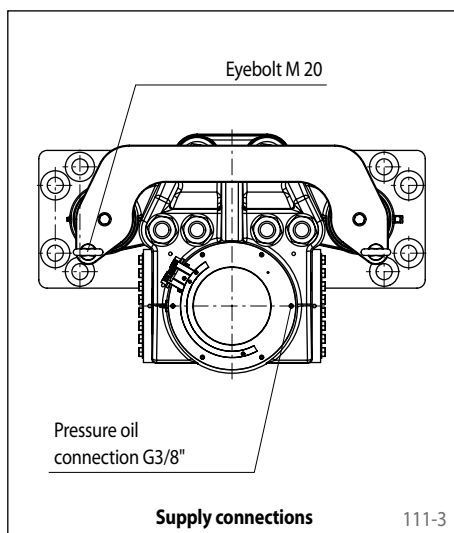
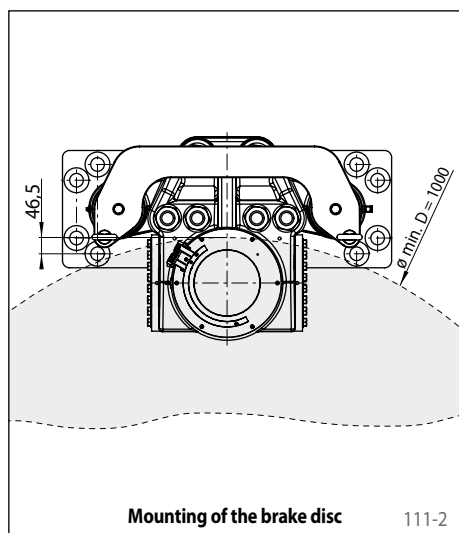

Brake Caliper HS 215 FHM-560 ... -H

spring activated – hydraulically released

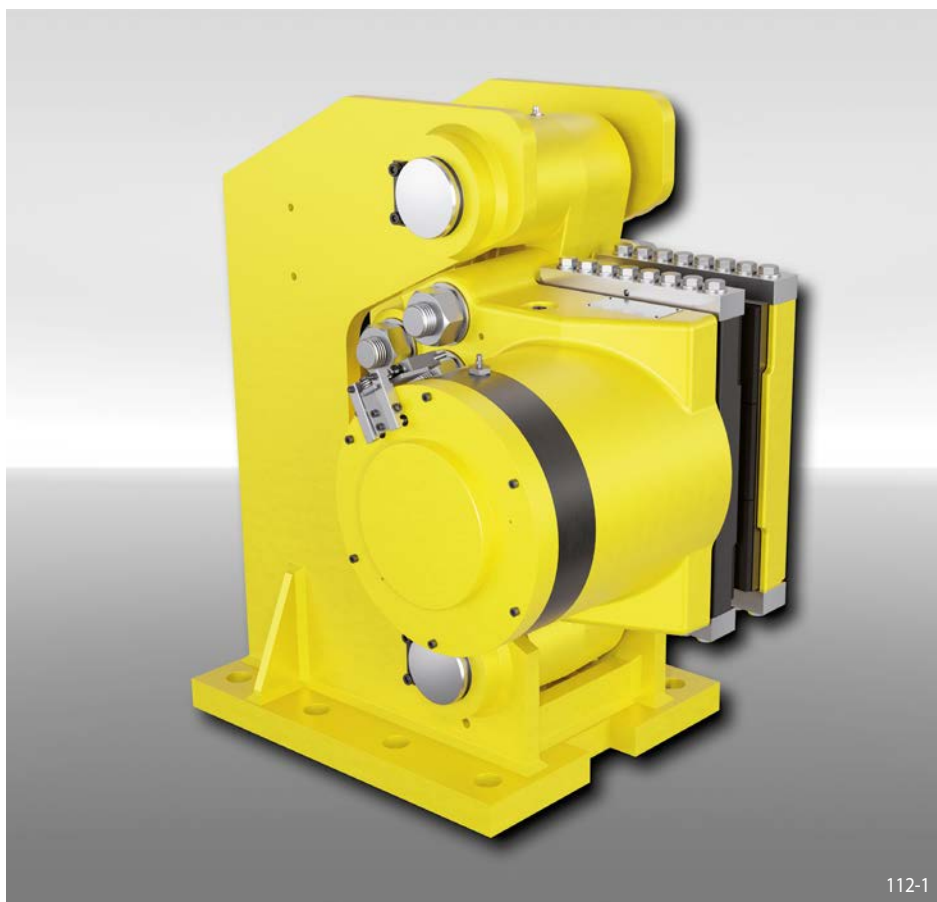

Features	Code
Brake Caliper	H
Floating caliper	S
Frame size 215	215
Spring activated	F
Hydraulically released	H
Manual adjustment to accommodate friction block wear	M
Max. clamping force 560 kN	560
Thruster mounted right or left available	R L
Mounting to the machine at right angles to the brake disc	H

Example for ordering

Brake Caliper HS 215 FHM, max. clamping force 560 kN, thruster mounted left, mounting to the machine at right angles to the brake disc:

HS 215 FHM-560 L-H

Technical Data

Brake disc diameter mm	Braking torque Nm
1 000	164 400
1 250	220 000
1 600	297 800
2 000	386 700
3 000	608 900
3 500	720 000
4 000	831 100
Clamping force	560 kN
Oil pressure	min. 230 bar max. 250 bar
Oil volume	max. 150 cm ³
Thickness of brake disc W	30 mm
Weight	880 kg

The braking torques shown in the table are based on a theoretical friction coefficient of 0,4.

Working conditions

- Ambient temperature: -20 °C / +60 °C
- Air humidity: <90%

Monitoring switch

- 240 VAC 1.5 A; 250 VDC 0.1 A
- Cable 5 x 0.75 mm², length 2 m, outer diameter 7.5 mm
- Protection type IP67

Options

- Integrated Hydraulic Power Unit
- Friction pads with wear indicator cables or sintered friction linings (for high temperatures)
- Corrosion-protected version
- Low temperature version
- Offshore certifications
- ATEX certifications for hazardous areas

Notes

- Eyebolts included
- Fastening:
8 screws M 36, class 8.8 with tightening torque 2 200 Nm ±10% μ 0.15 (not supplied)

Brake Caliper HS 215 FHM-560 ... -H

spring activated – hydraulically released

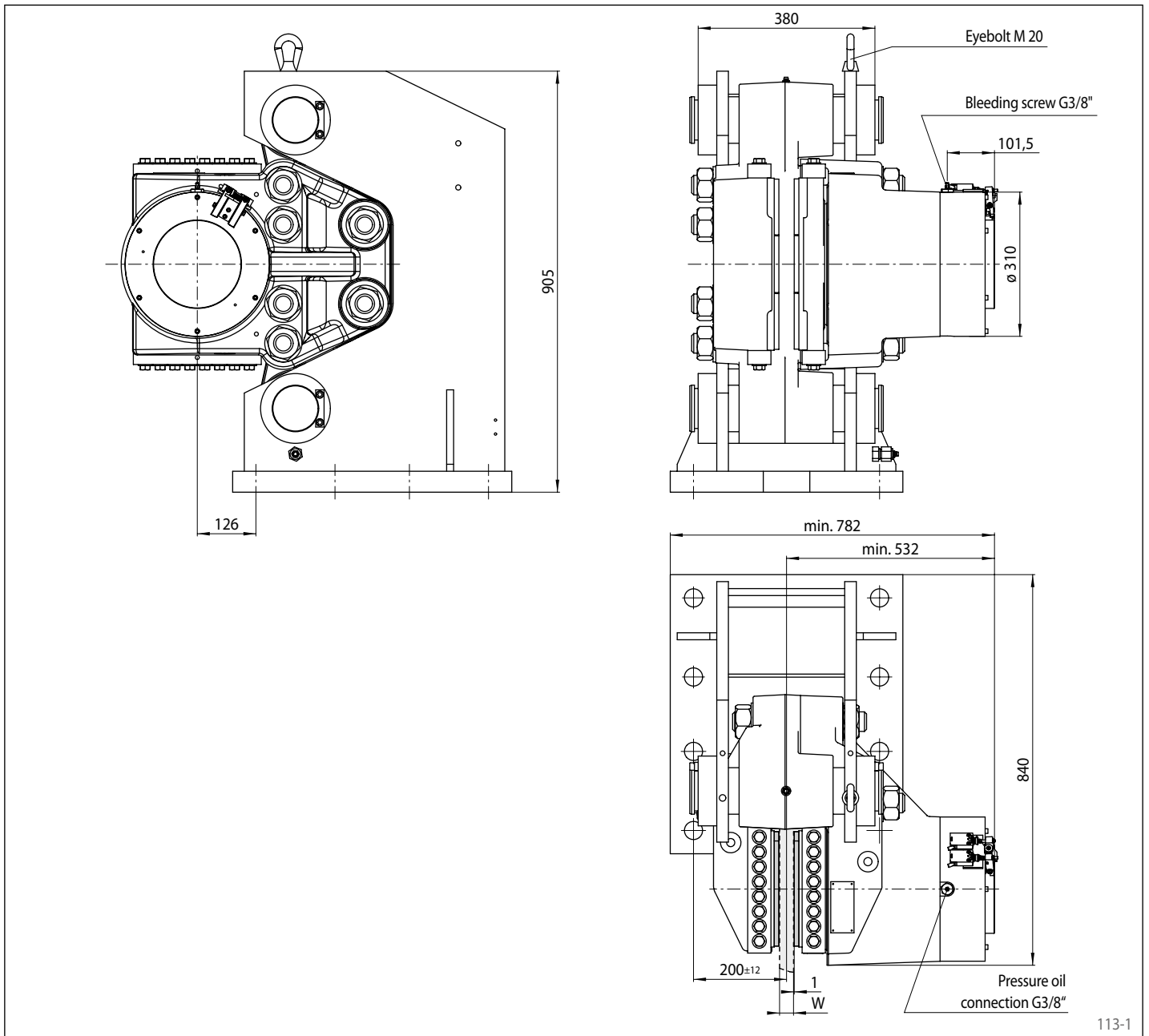

Mounting

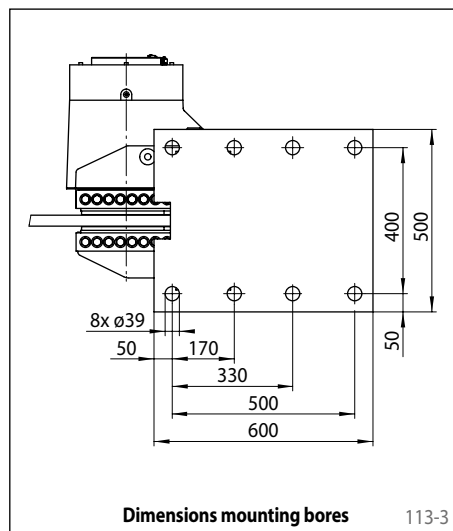
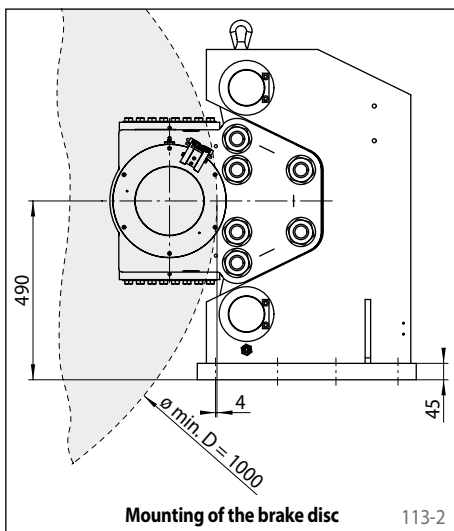

Brake Caliper HW 215 FHM

spring activated – hydraulically released

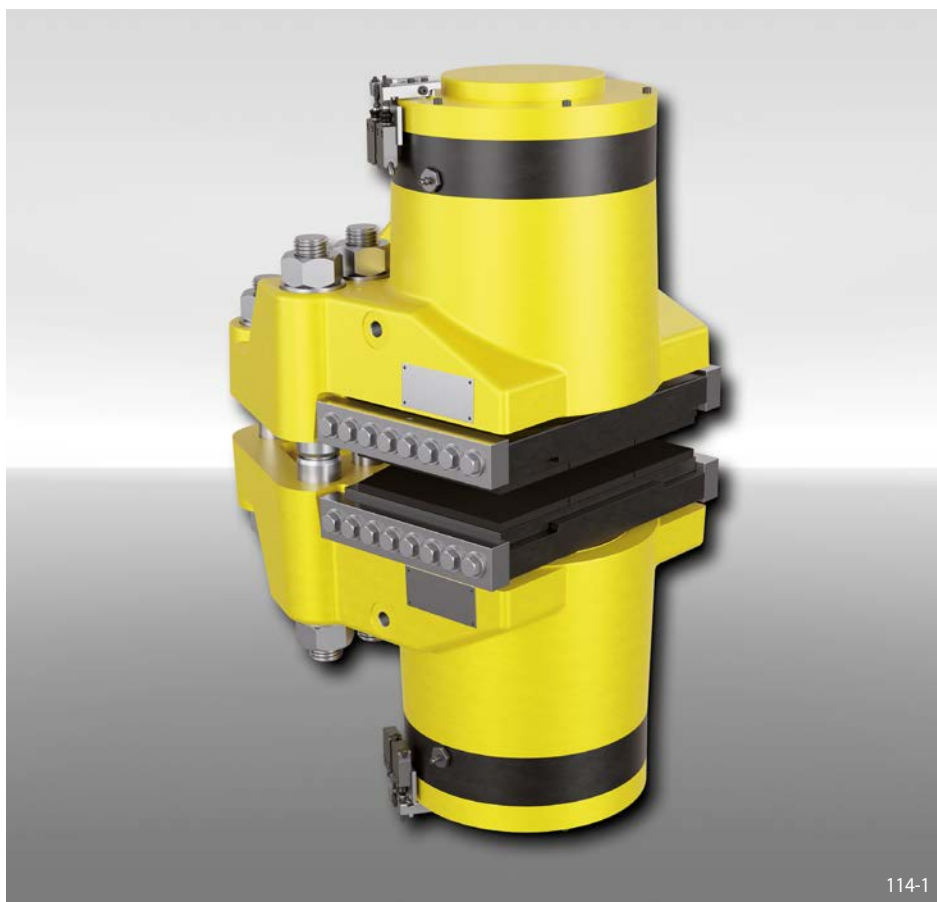

Features	Code
Brake Caliper	H
Standard	W
Frame size 215	215
Spring activated	F
Hydraulically released	H
Manual adjustment to accommodate friction block wear	M
Max. clamping force 560 kN	560

Example for ordering

Brake Caliper HW 215 FHM, max. clamping force 560 kN:

HW 215 FHM-560

Technical Data

Brake disc diameter mm	Braking torque Nm
1 000	164 400
1 250	220 000
1 600	297 800
2 000	386 700
3 000	608 900
3 500	720 000
4 000	831 100
Clamping force	560 kN
Oil pressure	min. 230 bar max. 250 bar
Oil volume	max. 270 cm ³
Thickness of brake disc W	min. 30 mm
Weight	650 kg

The braking torques shown in the table are based on a theoretical friction coefficient of 0,4.

Working conditions

- Ambient temperature: -20 °C / +60 °C
- Air humidity: <90%

Monitoring switch

- 240 VAC 1.5 A; 250 VDC 0.1 A
- Cable 5 x 0.75 mm², length 2 m, outer diameter 7.5 mm
- Protection type IP67

Options

- Friction pads with wear indicator cables or sintered friction linings (for high temperatures)
- Corrosion-protected version
- Low temperature version
- Offshore certifications
- ATEX certifications for hazardous areas

Notes

- Includes two pairs of ø 55_{g6} shear pins
- Eyebolts included
- Fastening:
6 screws M 42, class 10.9 with tightening torque 4 100 Nm ±5% μ 0.10 (not supplied)

Brake Caliper HW 215 FHM

spring activated – hydraulically released

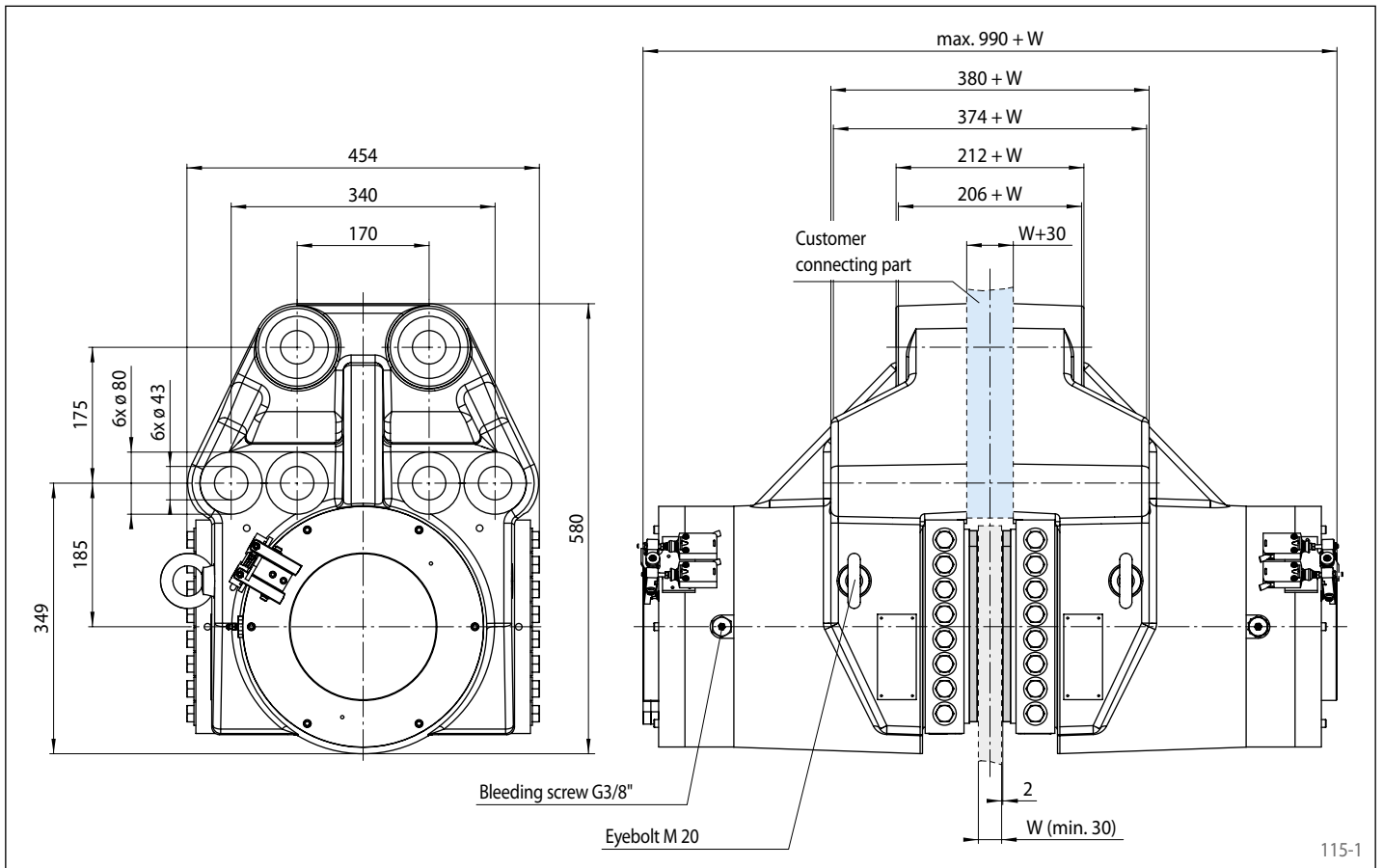

115-1

Mounting

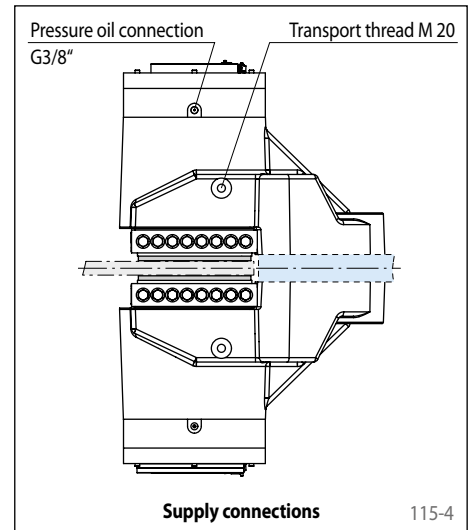
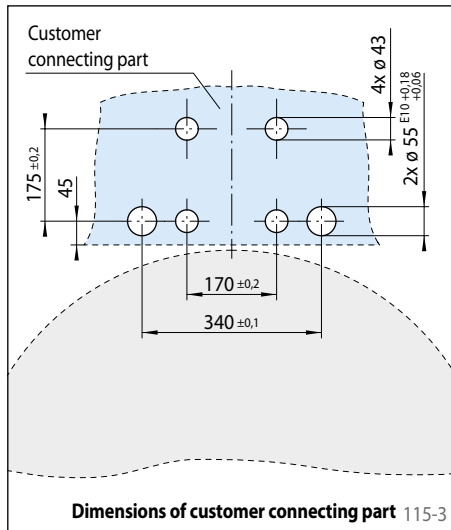
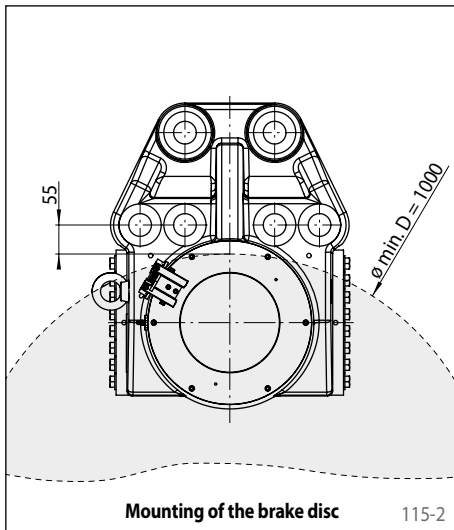

Brake Caliper HI 180 HUK

hydraulically activated – non-releasing
as yaw brake in wind turbines



Features	Code
Brake Caliper	H
With inside-mounted brake pads	I
Frame size 180	180
Hydraulically activated	H
Non-releasing	U
No adjustment to accommodate friction block wear	K
Max. clamping force 200 kN	200

Example for ordering

Brake Caliper HI 180 HUK, max. clamping force 200 kN:

HI 180 HUK - 200

Technical Data

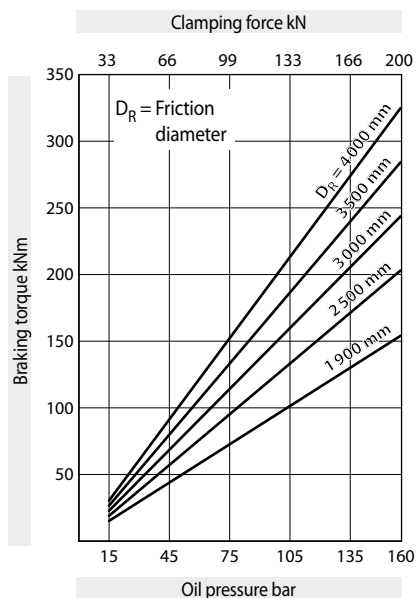

The braking torques shown in the diagram are based on a theoretical friction coefficient of 0,4.

Oil pressure: min. 15 bar
max. 160 bar

Oil volume: max. 190 cm³

Weight: ca. 65 kg

Other features

- High safety against leakage
- Painted with surface coating class C4-L according to ISO 12944
- For brake disc thickness $W = 30$ mm; larger brake disc thicknesses can be achieved with the use of a spacer installed by the customer

Accessories

- Optional painting with surface coating class C4-H or C5M-H (offshore) according to ISO 12944

Brake Caliper HI 180 HUK

hydraulically activated – non-releasing
as yaw brake in wind turbines

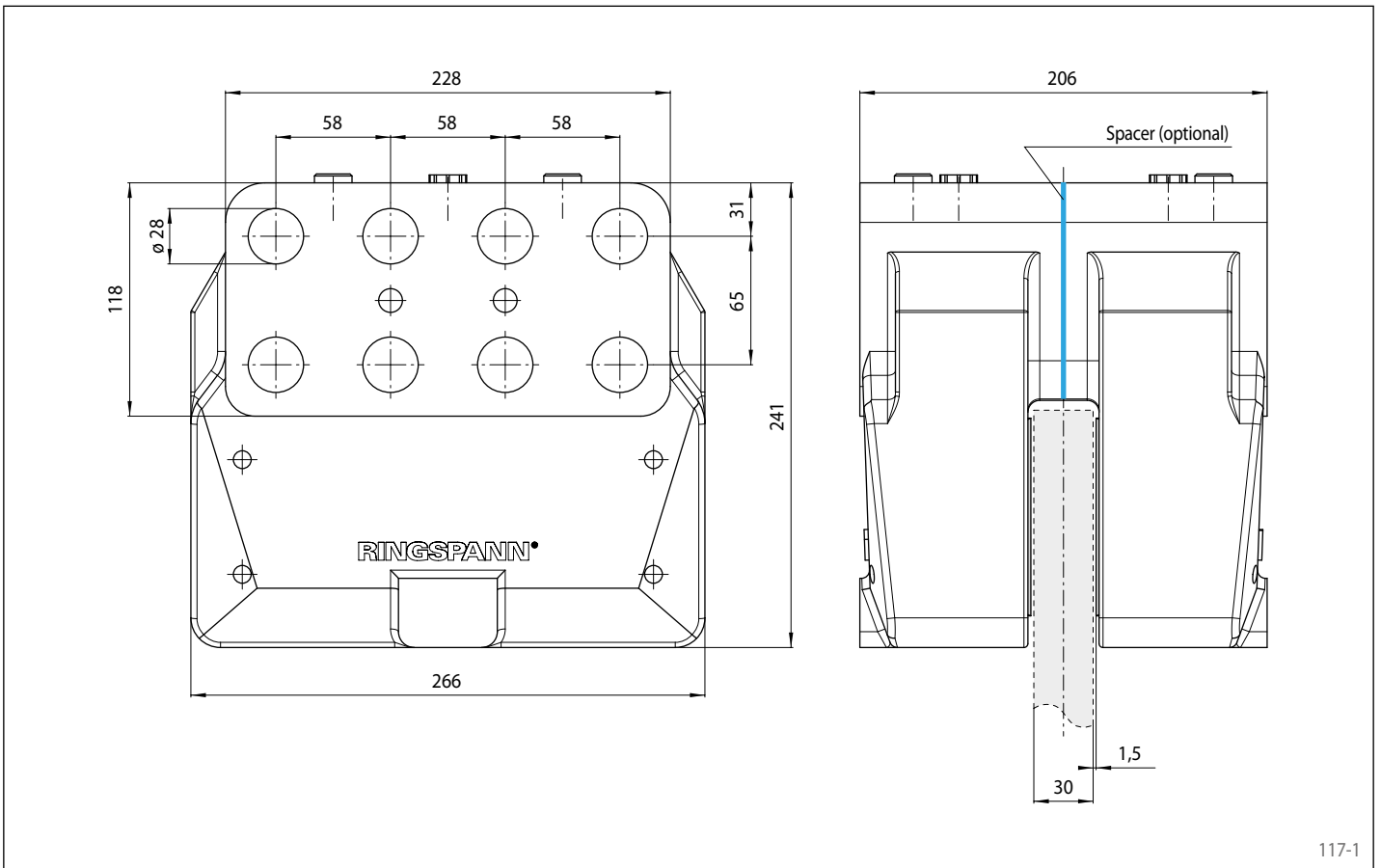

117-1

Mounting

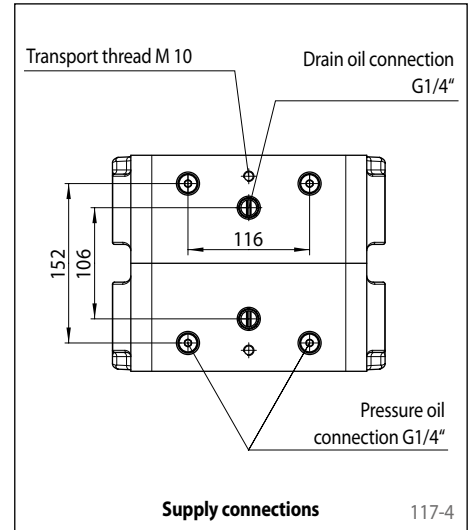
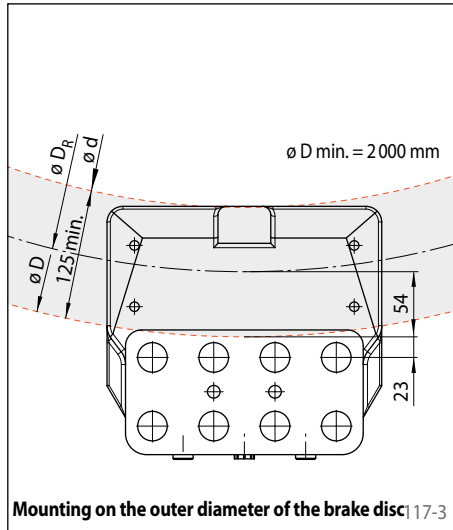
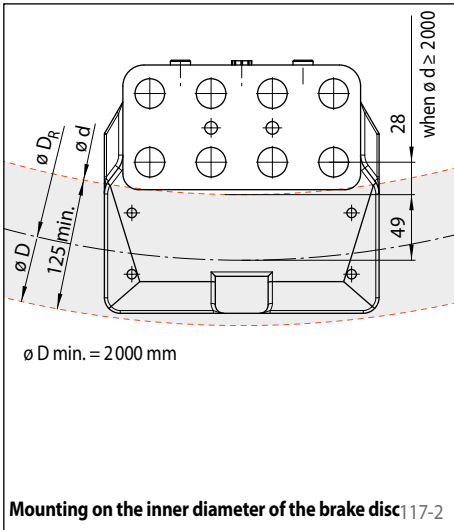

Calculation of the friction diameter

Mounting on the inner diameter of the brake disc:

$$D_R = d + (2 \cdot 49 \text{ mm})$$

(when $d \geq 2000$ mm)

Mounting on the outer diameter of the brake disc:

$$D_R = D - (2 \cdot 54 \text{ mm})$$

Calculation of the braking torque

$$M_B = \frac{D_R}{0,786} \cdot p \cdot \mu$$

Formula symbols

- M_B = Braking torque [Nm]
- D = Outer diameter brake disc [mm]
- d = Inner diameter brake disc [mm]
- D_R = Friction diameter [mm]
- p = Oil pressure [bar]
- μ = Friction coefficient

Brake Caliper HW 180 HUK

hydraulically activated – non-releasing
as yaw brake in wind turbines

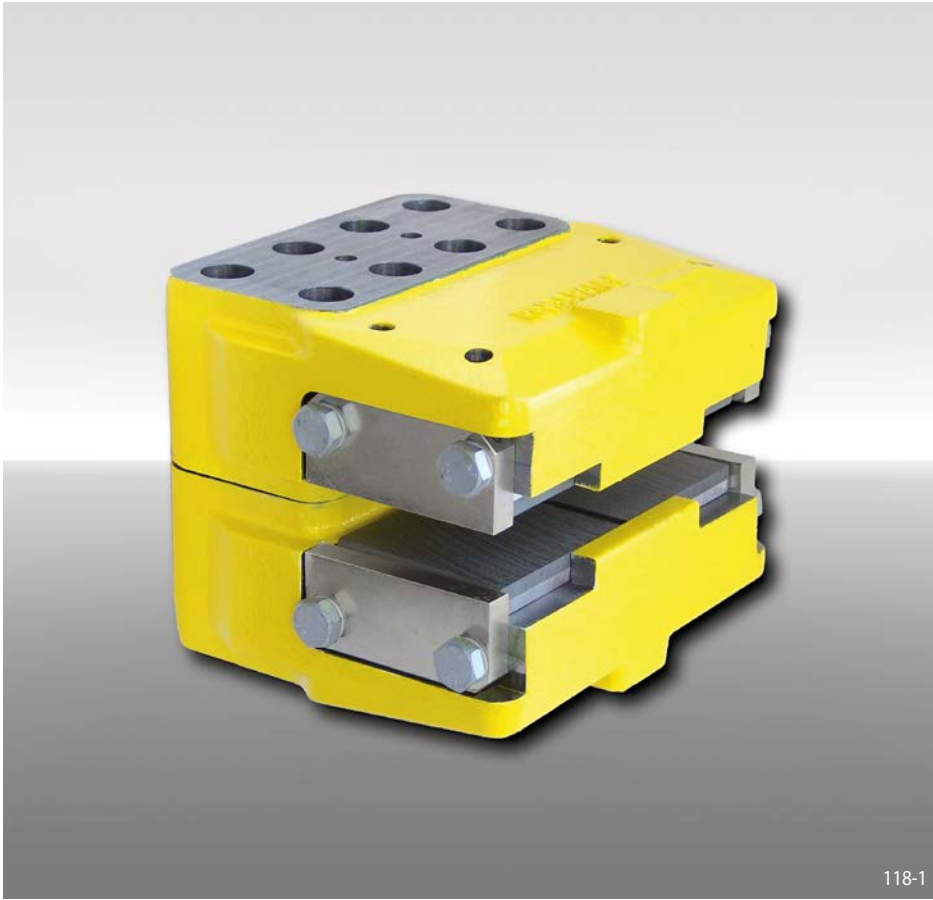

Features

Features	Code
Brake Caliper	H
Standard	W
Frame size 180	180
Hydraulically activated	H
Non-releasing	U
No adjustment to accommodate friction block wear	K
Max. clamping force 200 kN	200

Example for ordering

Brake Caliper HW 180 HUK, max. clamping force 200 kN:

HW 180 HUK - 200

Technical Data

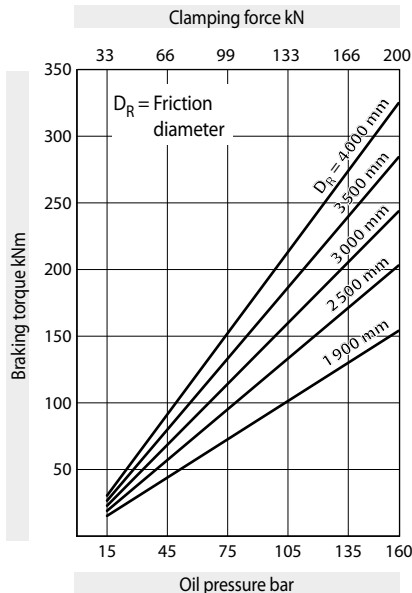

The braking torques shown in the diagram are based on a theoretical friction coefficient of 0,4.

Oil pressure: min. 15 bar
max. 160 bar

Oil volume: max. 190 cm³

Weight: ca. 65 kg

Other features

- High safety against leakage
- Easy change of friction blocks
- Painted with surface coating class C4-L according to ISO 12944
- For brake disc thickness $W = 30$ mm; larger brake disc thicknesses can be achieved with the use of a spacer installed by the customer

Accessories

- Optional painting with surface coating class C4-H or C5M-H (offshore) according to ISO 12944

Brake Caliper HW 180 HUK

hydraulically activated – non-releasing
as yaw brake in wind turbines

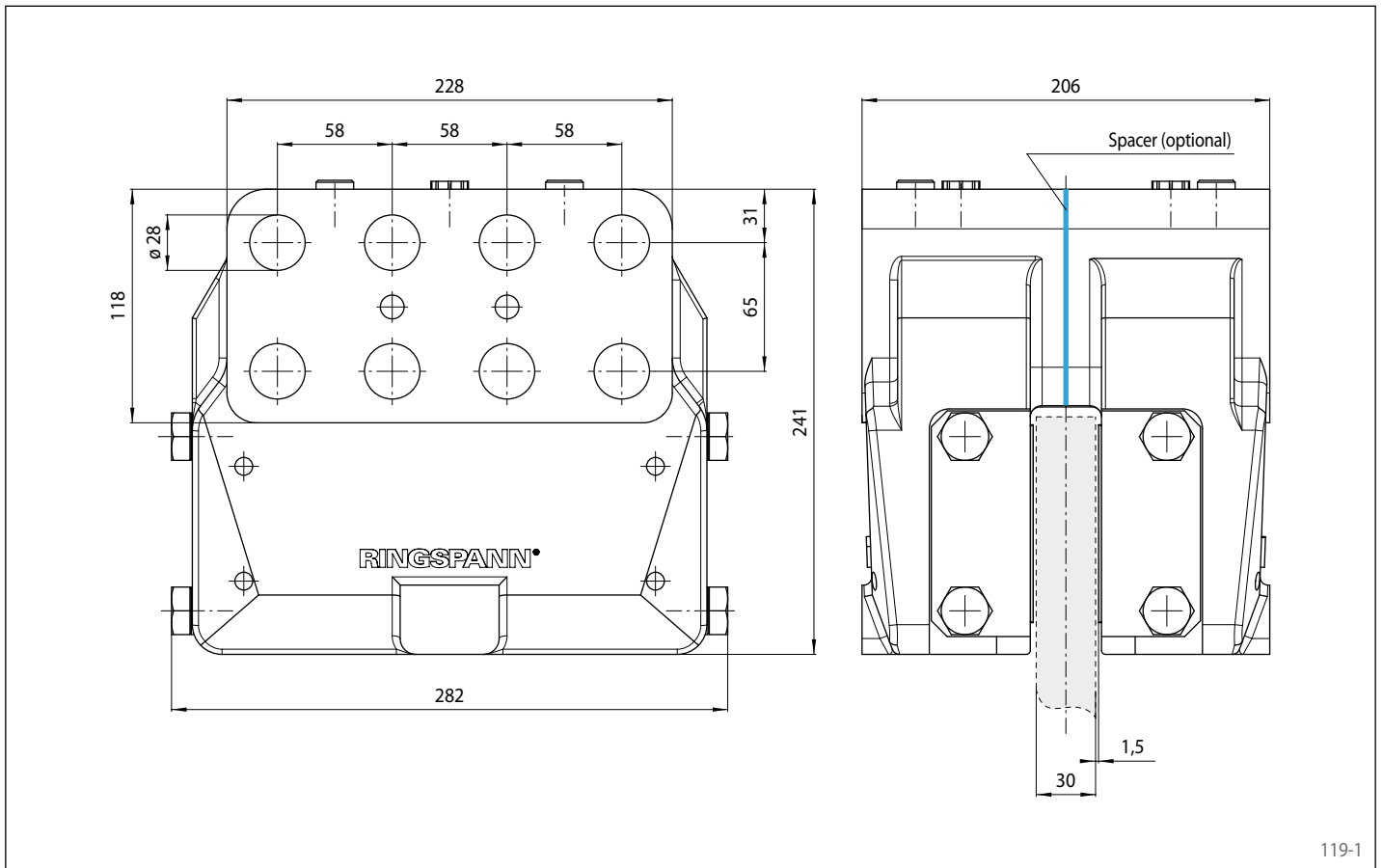

119-1

Mounting

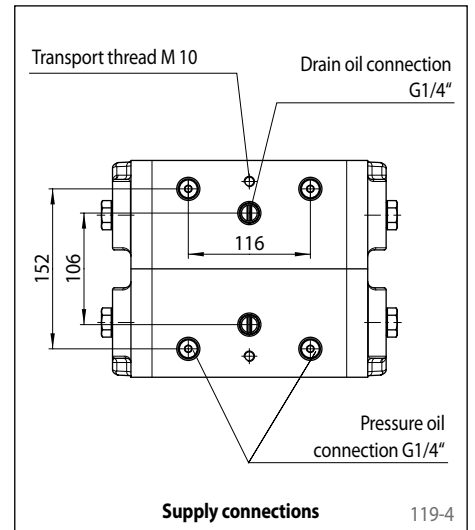
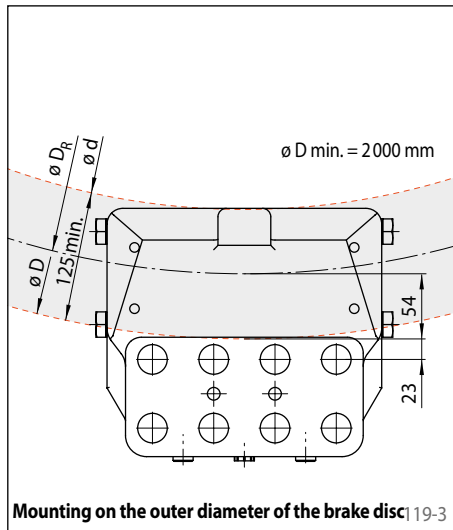
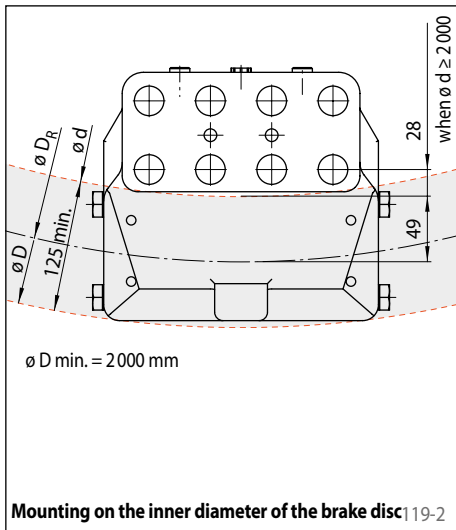

Calculation of the friction diameter

Mounting on the inner diameter of the brake disc:

$$D_R = d + (2 \cdot 49 \text{ mm})$$

(when $d \geq 2000 \text{ mm}$)

Mounting on the outer diameter of the brake disc:

$$D_R = D - (2 \cdot 54 \text{ mm})$$

Calculation of the braking torque

$$M_B = \frac{D_R}{0,786} \cdot p \cdot \mu$$

Formula symbols

- M_B = Braking torque [Nm]
- D = Outer diameter brake disc [mm]
- d = Inner diameter brake disc [mm]
- D_R = Friction diameter [mm]
- p = Oil pressure [bar]
- μ = Friction coefficient

Brake Caliper HW 040 HFA

hydraulically activated – spring released

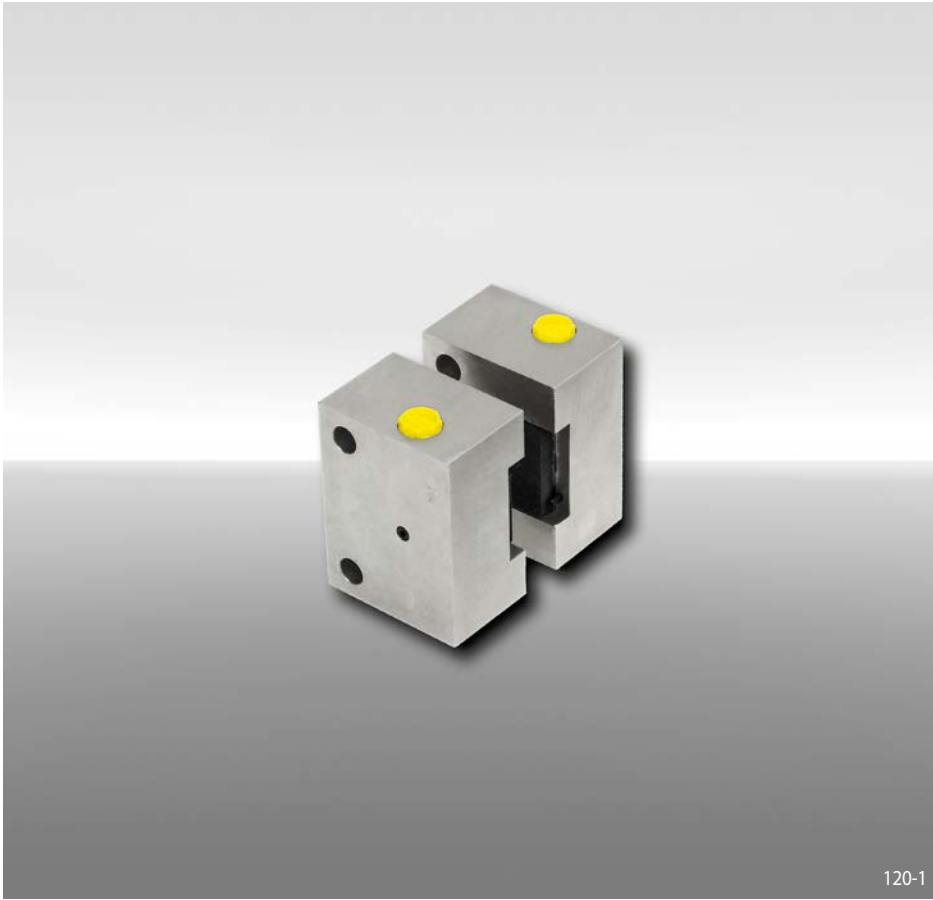

Features

Features	Code
Brake Caliper	H
Standard	W
Frame size 040	040
Hydraulically activated	H
Spring released	F
Automatic adjustment to accommodate friction block wear	A
Max. clamping force 11 kN	011

Example for ordering

Brake Caliper HW 040 HFA, max. clamping force 11 kN:

HW 040 HFA - 011

Technical Data

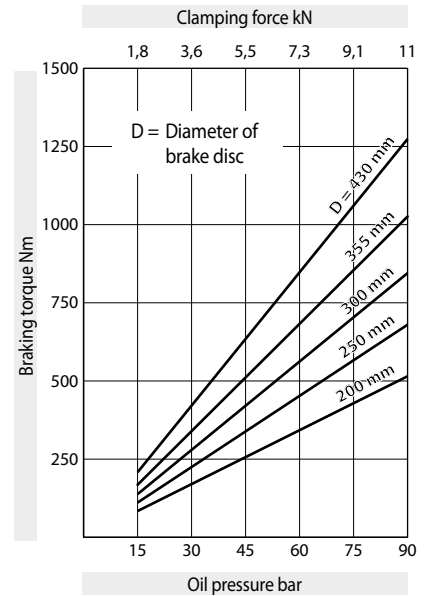
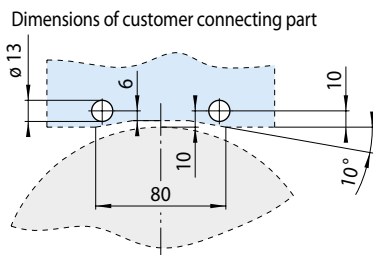
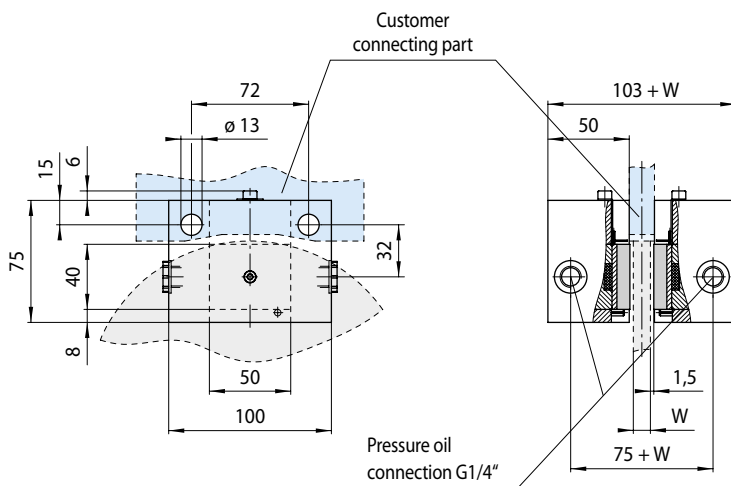

The braking torques shown in the diagram are based on a theoretical friction coefficient of 0,3.

Oil pressure: min. 5 bar
max. 90 bar

Oil volume: max. 20 cm³

Weight: 5,5 kg

Other features

- The thickness of the customer connecting part results from the thickness of the brake disc W plus 3 mm

120-1

120-2

Brake Caliper HW 063 HFA

hydraulically activated – spring released

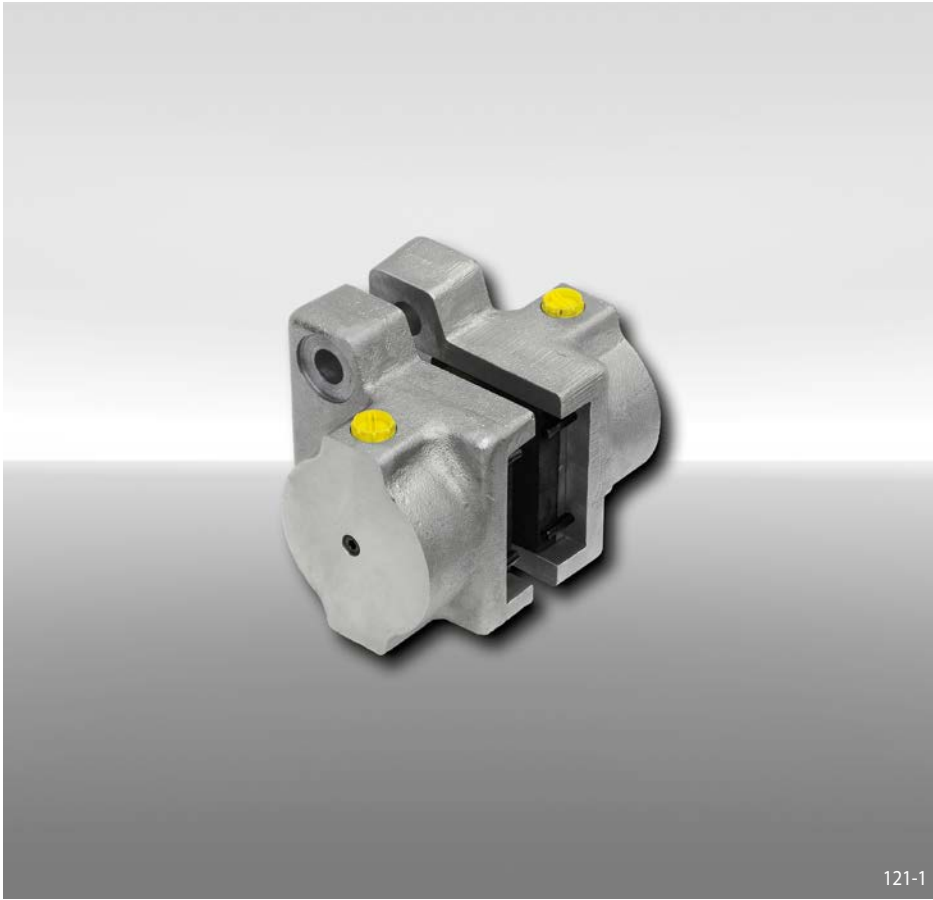

Features

Features	Code
Brake Caliper	H
Standard	W
Frame size 063	063
Hydraulically activated	H
Spring released	F
Automatic adjustment to accommodate friction block wear	A
Max. clamping force 28 kN	028

Example for ordering

Brake Caliper HW 063 HFA, max. clamping force 28 kN:

HW 063 HFA - 028

Technical Data

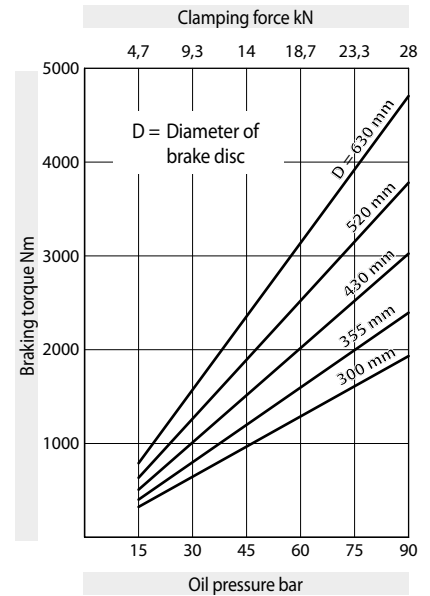
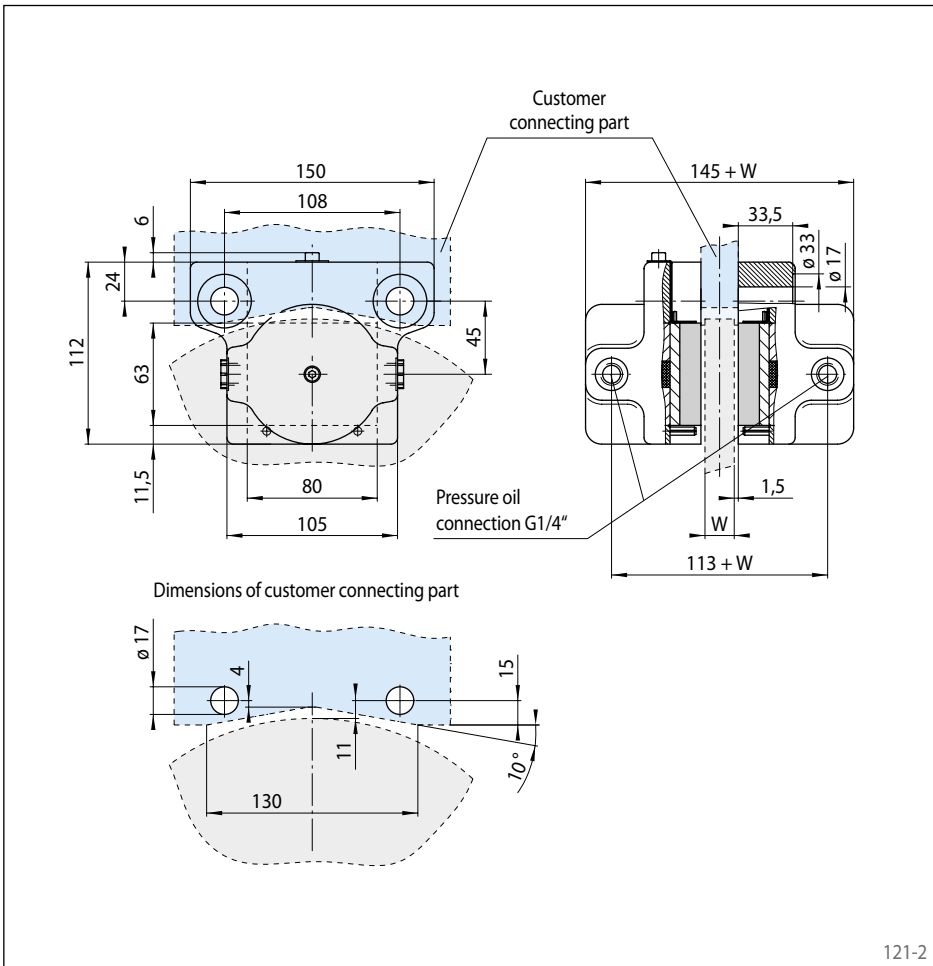

The braking torques shown in the diagram are based on a theoretical friction coefficient of 0,3.

Oil pressure: min. 5 bar
max. 90 bar

Oil volume: max. 78 cm³

Weight: 8 kg

Other features

- The thickness of the customer connecting part results from the thickness of the brake disc W plus 3 mm

Brake Caliper HS 075 HFK

hydraulically activated – spring released



Features

Features	Code
Brake Caliper	H
Floating caliper	S
Frame size 075	075
Hydraulically activated	H
Spring released	F
No adjustment to accommodate friction block wear	K
Max. clamping force 55 kN	055

Example for ordering

Brake Caliper HS 075 HFK, max. clamping force 55 kN:

HS 075 HFK - 055

Technical Data

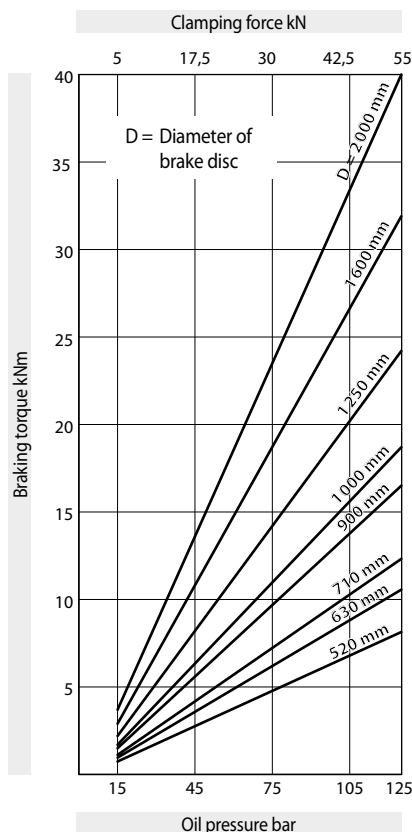

Oil pressure: min. 15 bar
max. 125 bar

Oil volume: max. 70 cm³

Weight: ca. 80 kg

Other features

- High safety against leakage
- Easy change of friction blocks
- Painted with surface coating class C4-L according to ISO 12944
- For brake disc thickness $W = 20$ mm; brake disc thicknesses of up to 40 mm can be achieved with the use of a spacer installed by the customer

Accessories

- Inductive proximity switch for "brake released" operating status
- Inductive proximity switch for brake pad wear control
- Optional painting with surface coating class C4-H or C5M-H (offshore) according to ISO 12944

The braking torques shown in the diagram are based on a theoretical friction coefficient of 0,4.

Brake Caliper HS 075 HFK

hydraulically activated – spring released

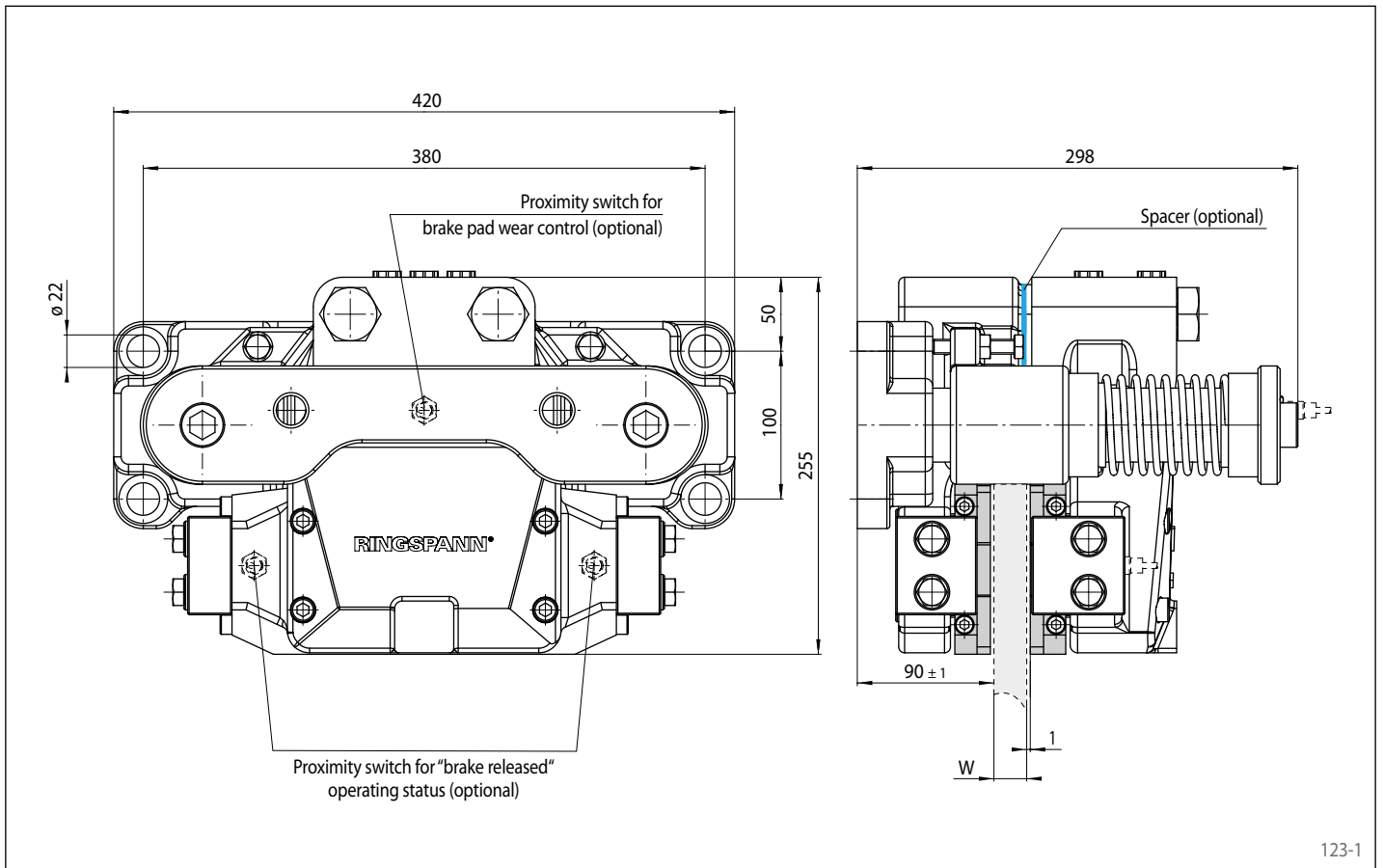

123-1

Mounting

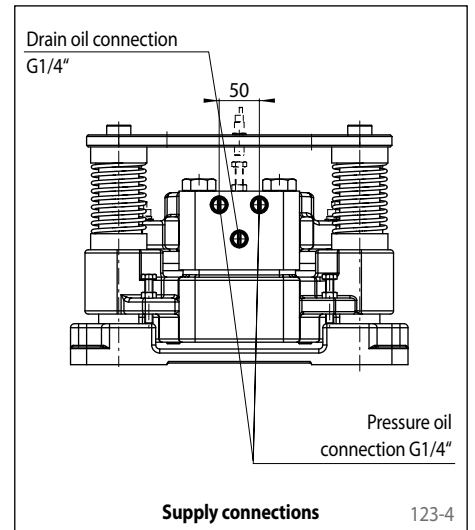
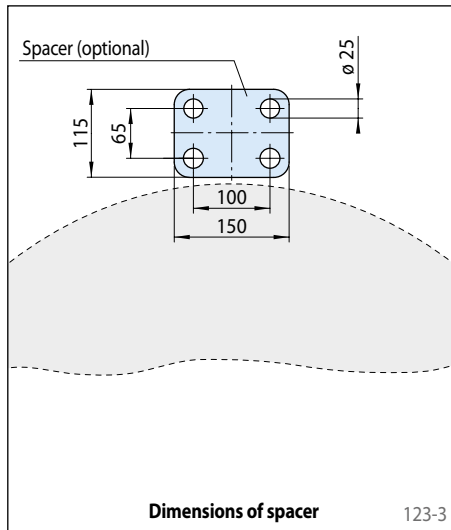
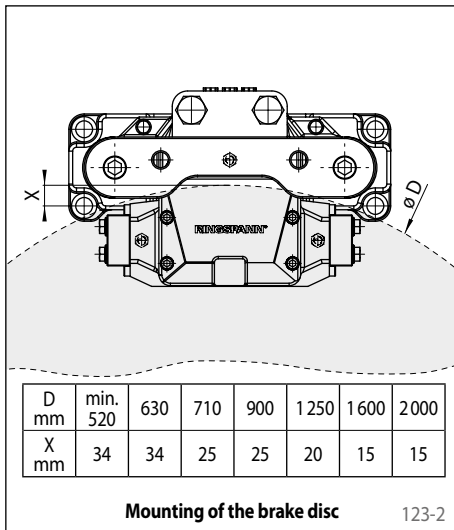

Brake Caliper HW 075 HFK

hydraulically activated – spring released

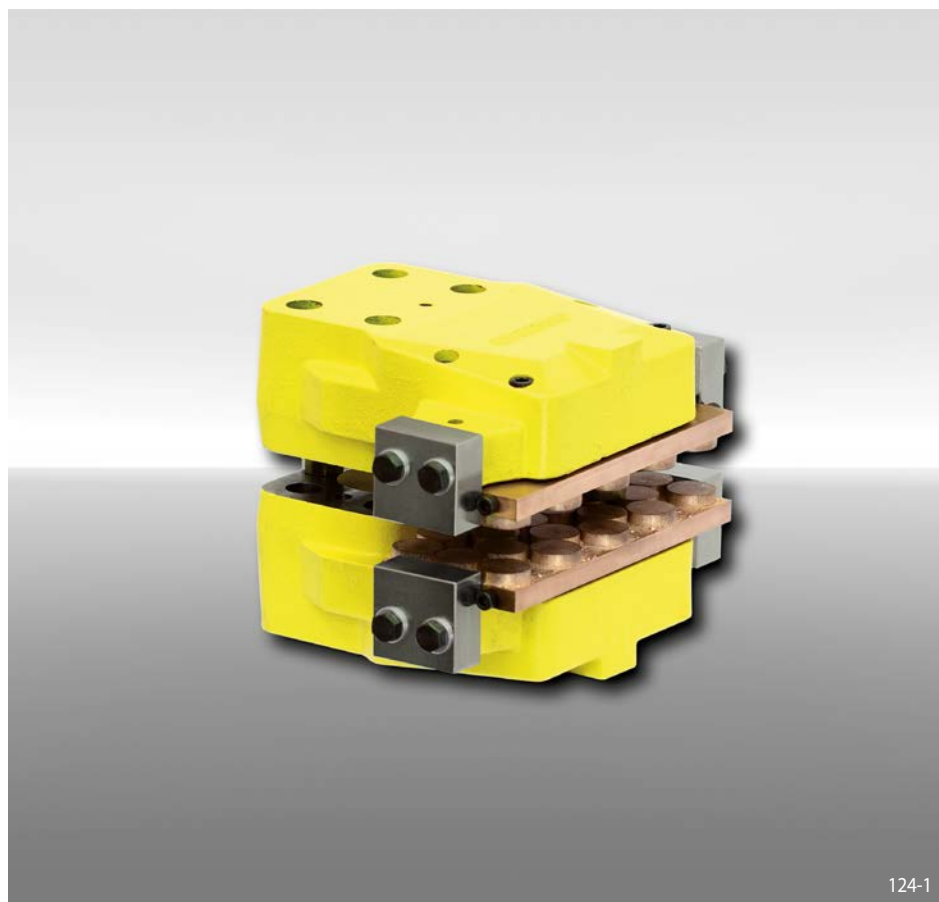

Features	Code
Brake Caliper	H
Standard	W
Frame size 075	075
Hydraulically activated	H
Spring released	F
No adjustment to accommodate friction block wear	K
Max. clamping force 55 kN	055

Example for ordering

Brake Caliper HW 075 HFK, max. clamping force 55 kN:

HW 075 HFK - 055

Technical Data

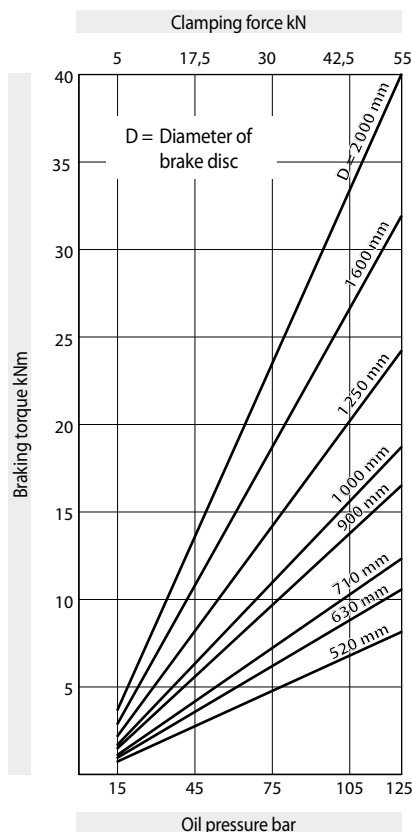

Oil pressure: min. 15 bar
max. 125 bar

Oil volume: max. 75 cm³

Weight: ca. 60 kg

The braking torques shown in the diagram are based on a theoretical friction coefficient of 0,4.

Other features

- High safety against leakage
- Easy change of friction blocks
- Painted with surface coating class C4-L according to ISO 12944
- The thickness of the customer connecting part results from the thickness of the brake disc W plus 3 mm

Accessories

- Inductive proximity switch for "brake released" operating status
- Optional painting with surface coating class C4-H or C5M-H (offshore) according to ISO 12944

Brake Caliper HW 075 HFK

hydraulically activated – spring released

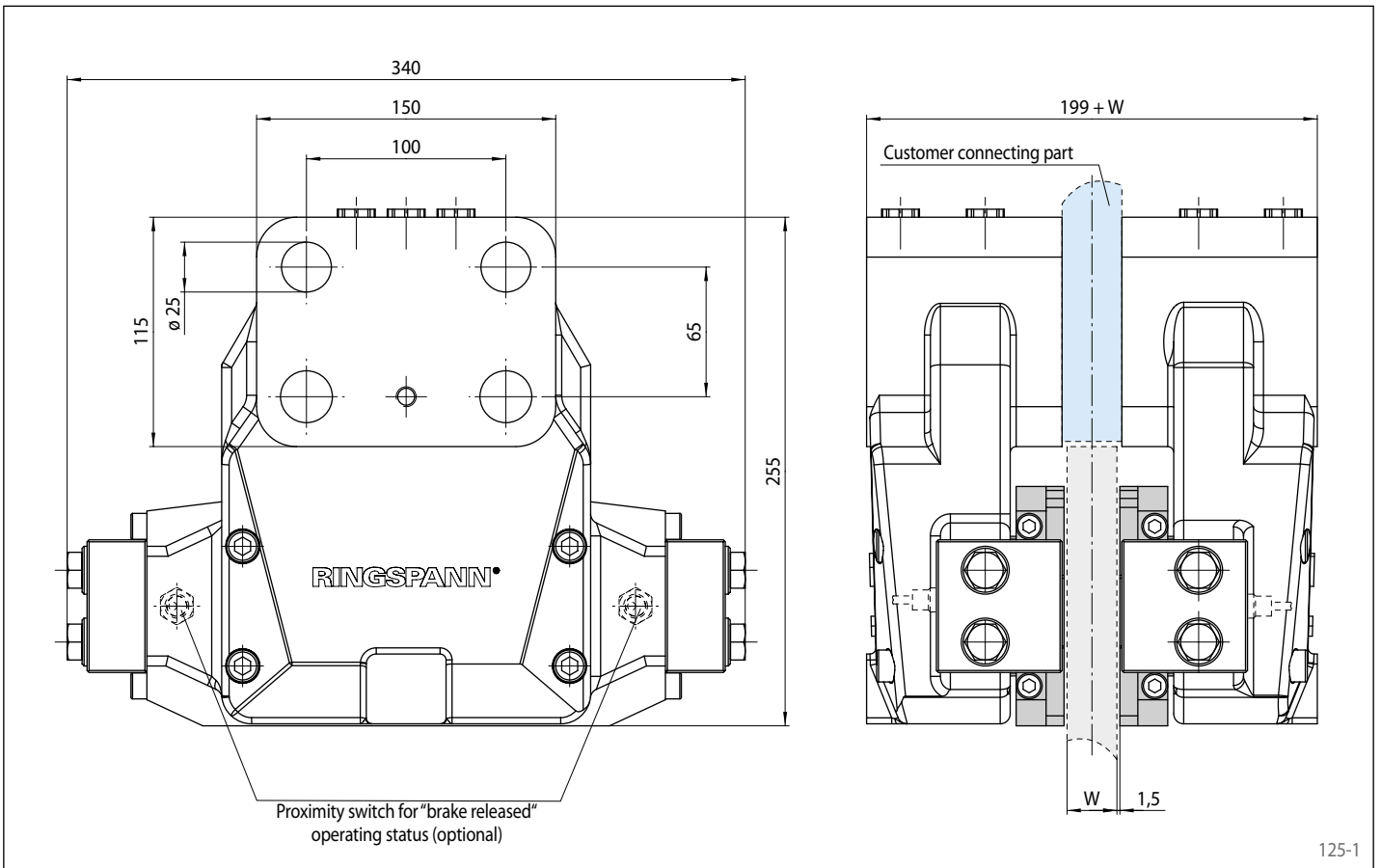

125-1

Mounting

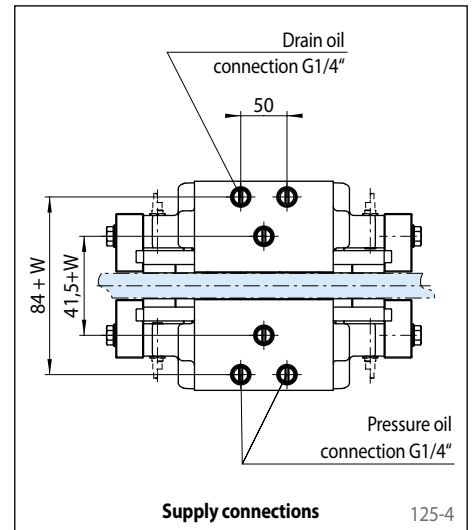
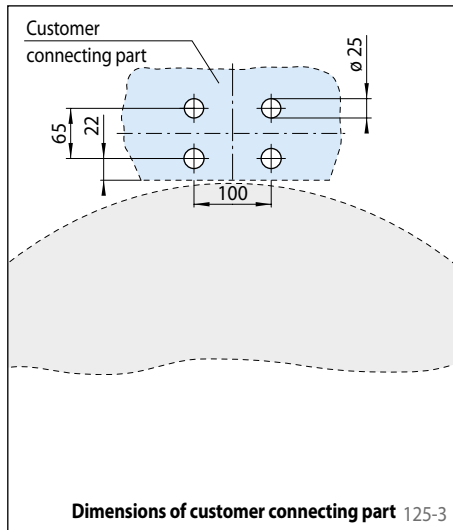
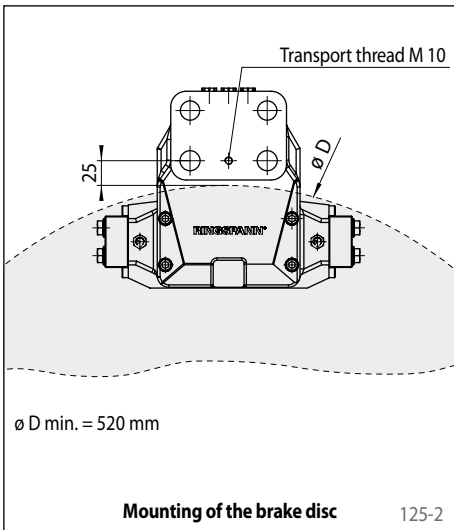

Brake Caliper HW 100 HFA

hydraulically activated – spring released



Features

Features	Code
Brake Caliper	H
Standard	W
Frame size 100	100
Hydraulically activated	H
Spring released	F
Automatic adjustment to accommodate friction block wear	A
Max. clamping force 70 kN	070

Example for ordering

Brake Caliper HW 100 HFA, max. clamping force 70 kN:

HW 100 HFA - 070

Technical Data

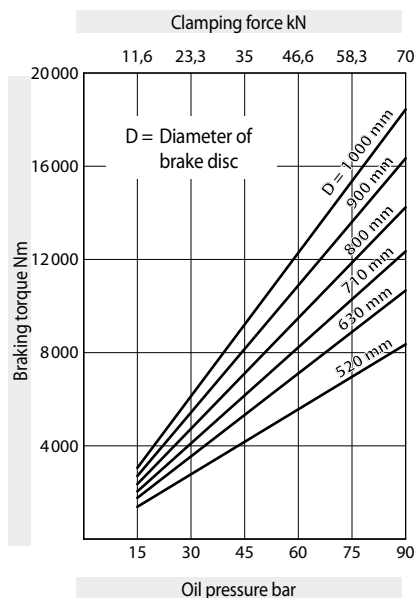

The braking torques shown in the diagram are based on a theoretical friction coefficient of 0,3.

Oil pressure: min. 5 bar
max. 90 bar

Oil volume: max. 298 cm³

Weight: 30 kg

Other features

- The thickness of the customer connecting part results from the thickness of the brake disc W plus 3 mm

Brake Caliper HW 100 HFA

hydraulically activated – spring released

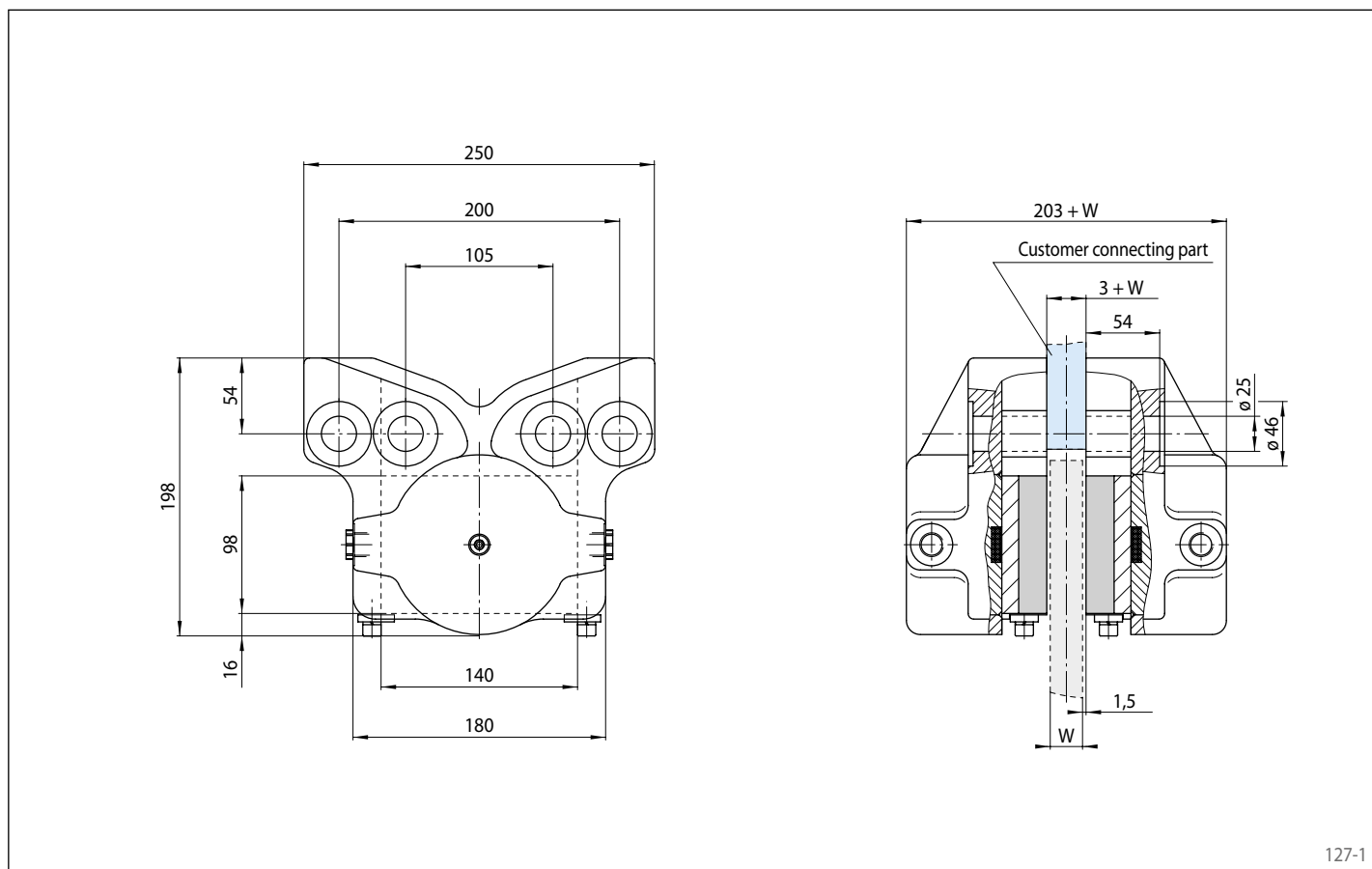

127-1

Mounting

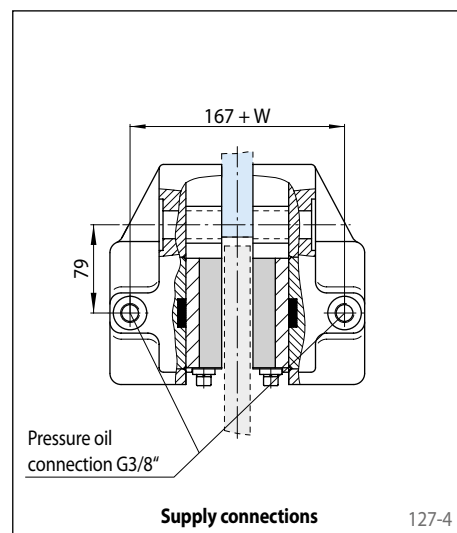
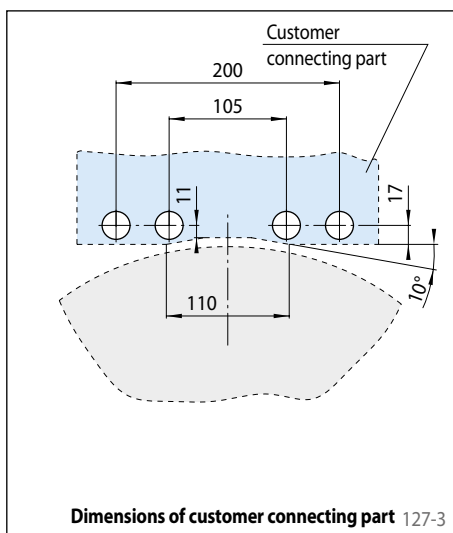
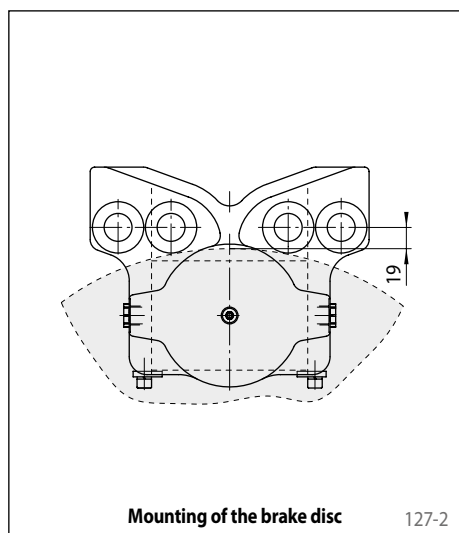

Brake Caliper HS 120 HFK

hydraulically activated – spring released
for wind turbines or conveyor systems

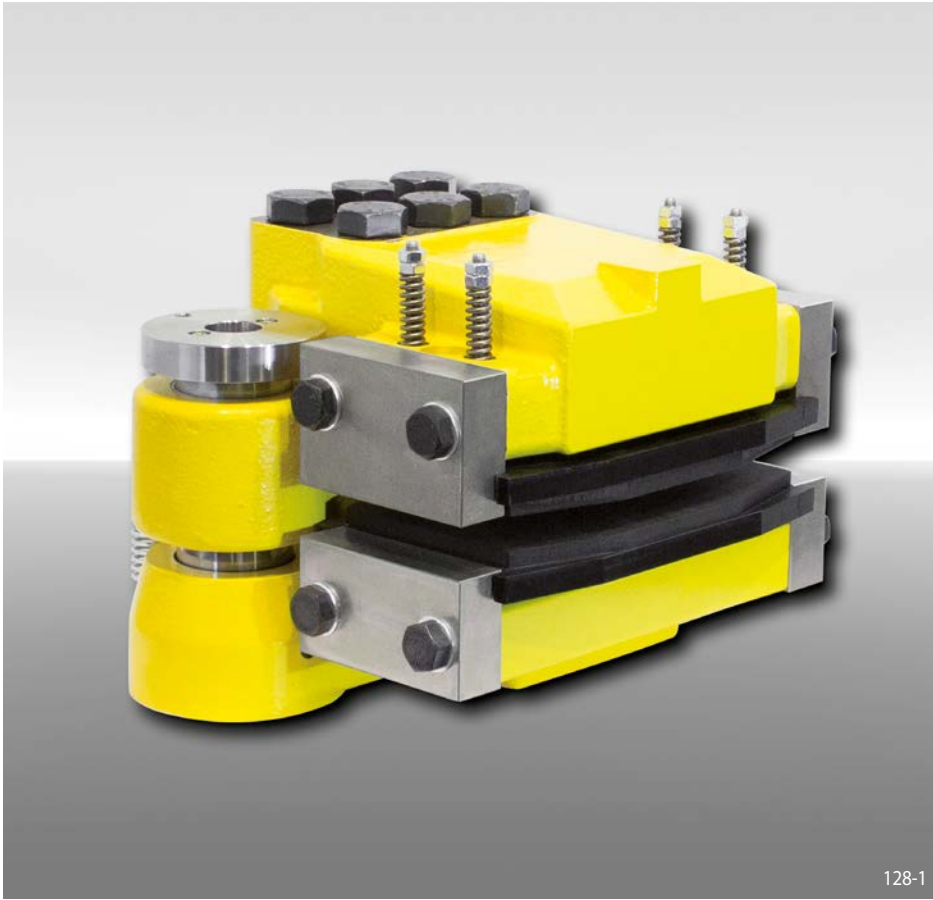

Features

Features	Code
Brake Caliper	H
Floating caliper	S
Frame size 120	120
Hydraulically activated	H
Spring released	F
No adjustment to accommodate friction block wear	K
Max. clamping force 130 kN	130

Example for ordering

Brake Caliper HS 120 HFK, max. clamping force 130 kN:

HS 120 HFK - 130

Technical Data

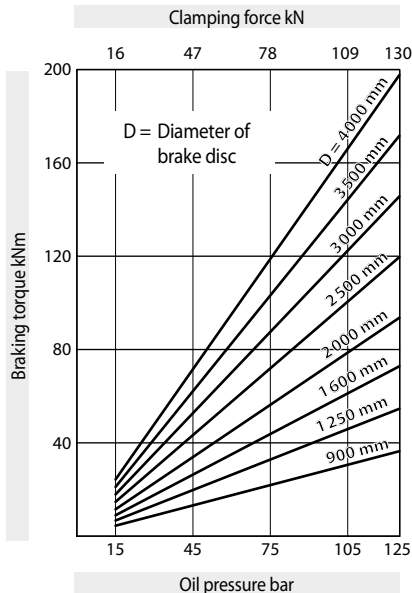

The braking torques shown in the diagram are based on a theoretical friction coefficient of 0,4.

Oil pressure: min. 15 bar
max. 125 bar

Oil volume: max. 203 cm³

Weight: ca. 195 kg

Other features

- High safety against leakage
- Easy change of friction blocks
- Painted with surface coating class C4-L according to ISO 12944
- For brake disc thickness $W = 20$ mm; brake disc thicknesses of up to 40 mm can be achieved with the use of a spacer installed by the customer

Accessories

- Inductive proximity switch for "brake released" operating status
- Inductive proximity switch for brake pad wear control
- Optional painting with surface coating class C4-H or C5M-H (offshore) according to ISO 12944

Brake Caliper HS 120 HFK

hydraulically activated – spring released
for wind turbines or conveyor systems

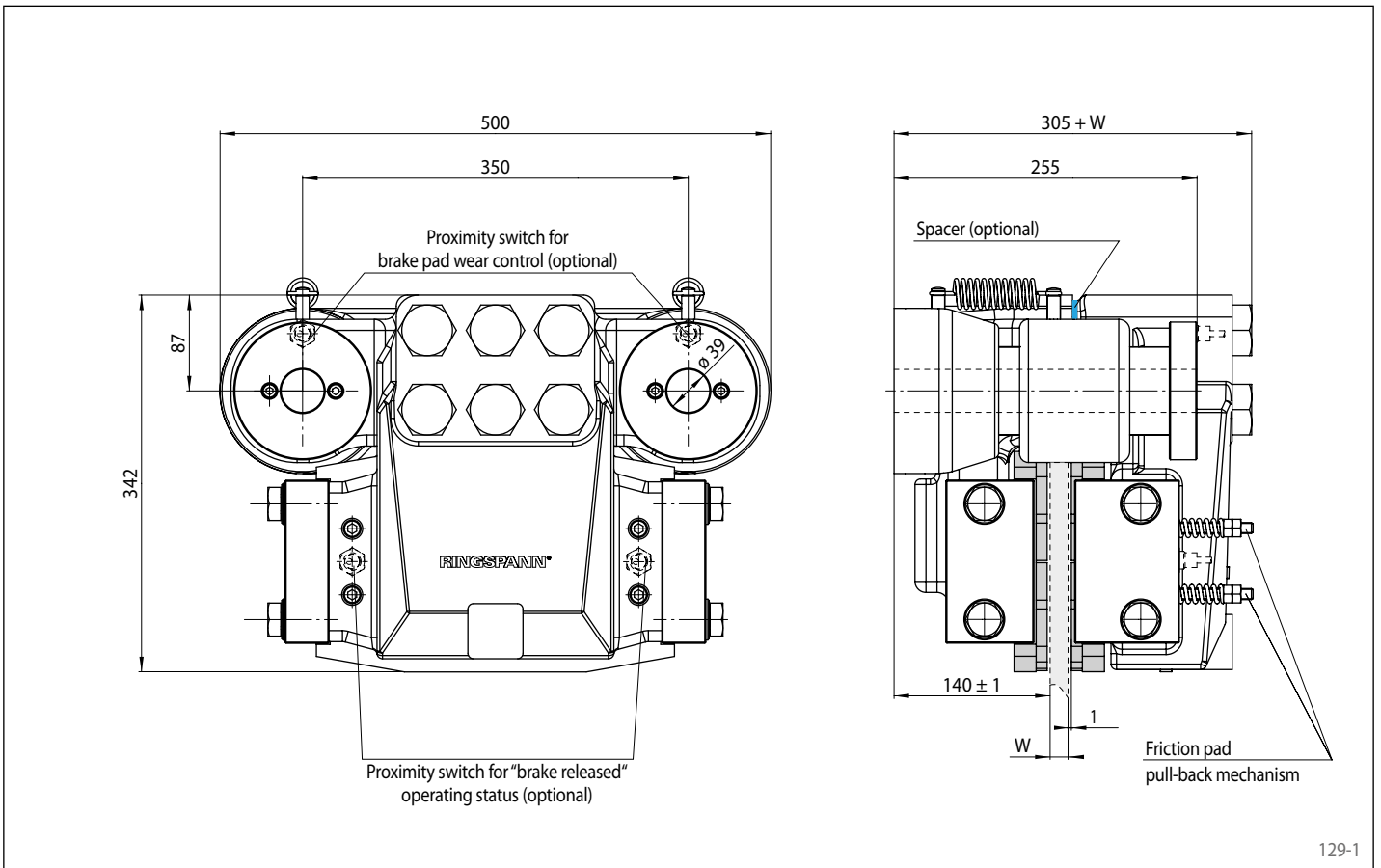

129-1

Mounting

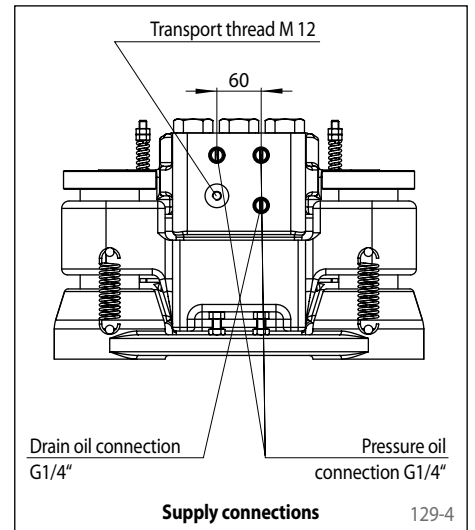
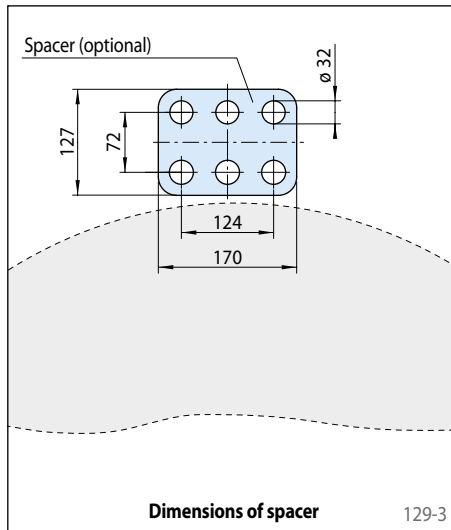
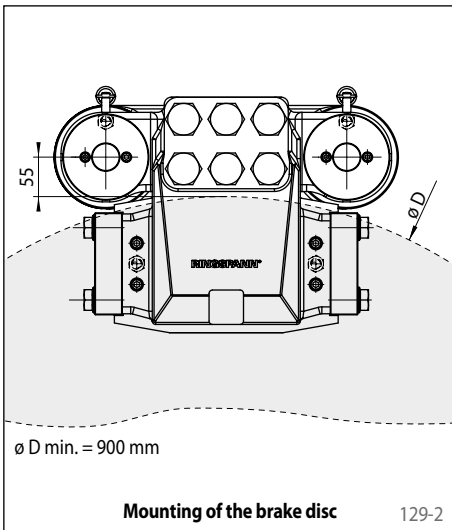

Brake Caliper HW 120 HFK

hydraulically activated – spring released

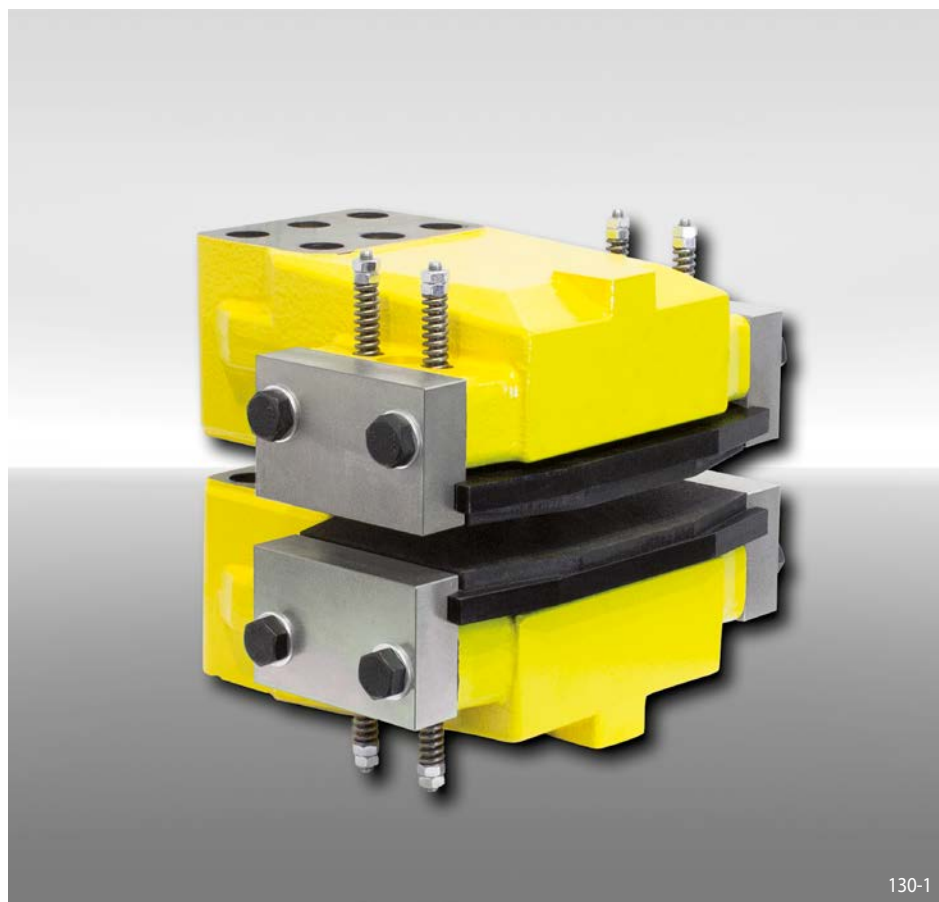

Features

Features	Code
Brake Caliper	H
Standard	W
Frame size 120	120
Hydraulically activated	H
Spring released	F
No adjustment to accommodate friction block wear	K
Max. clamping force 130 kN	130

Example for ordering

Brake Caliper HW 120 HFK, max. clamping force 130 kN:

HW 120 HFK - 130

Technical Data

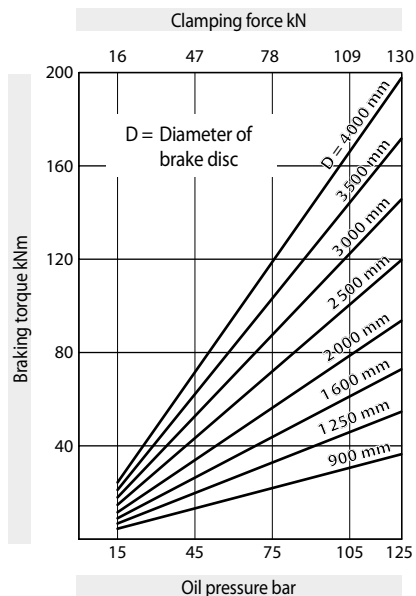

The braking torques shown in the diagram are based on a theoretical friction coefficient of 0,4.

Oil pressure: min. 15 bar
max. 125 bar

Oil volume: max. 214 cm³

Weight: ca. 146 kg

Other features

- High safety against leakage
- Easy change of friction blocks
- Painted with surface coating class C4-L according to ISO 12944
- The thickness of the customer connecting part results from the thickness of the brake disc W plus 3 mm

Accessories

- Inductive proximity switch for "brake released" operating status
- Optional painting with surface coating class C4-H or C5M-H (offshore) according to ISO 12944

Brake Caliper HW 120 HFK

hydraulically activated – spring released

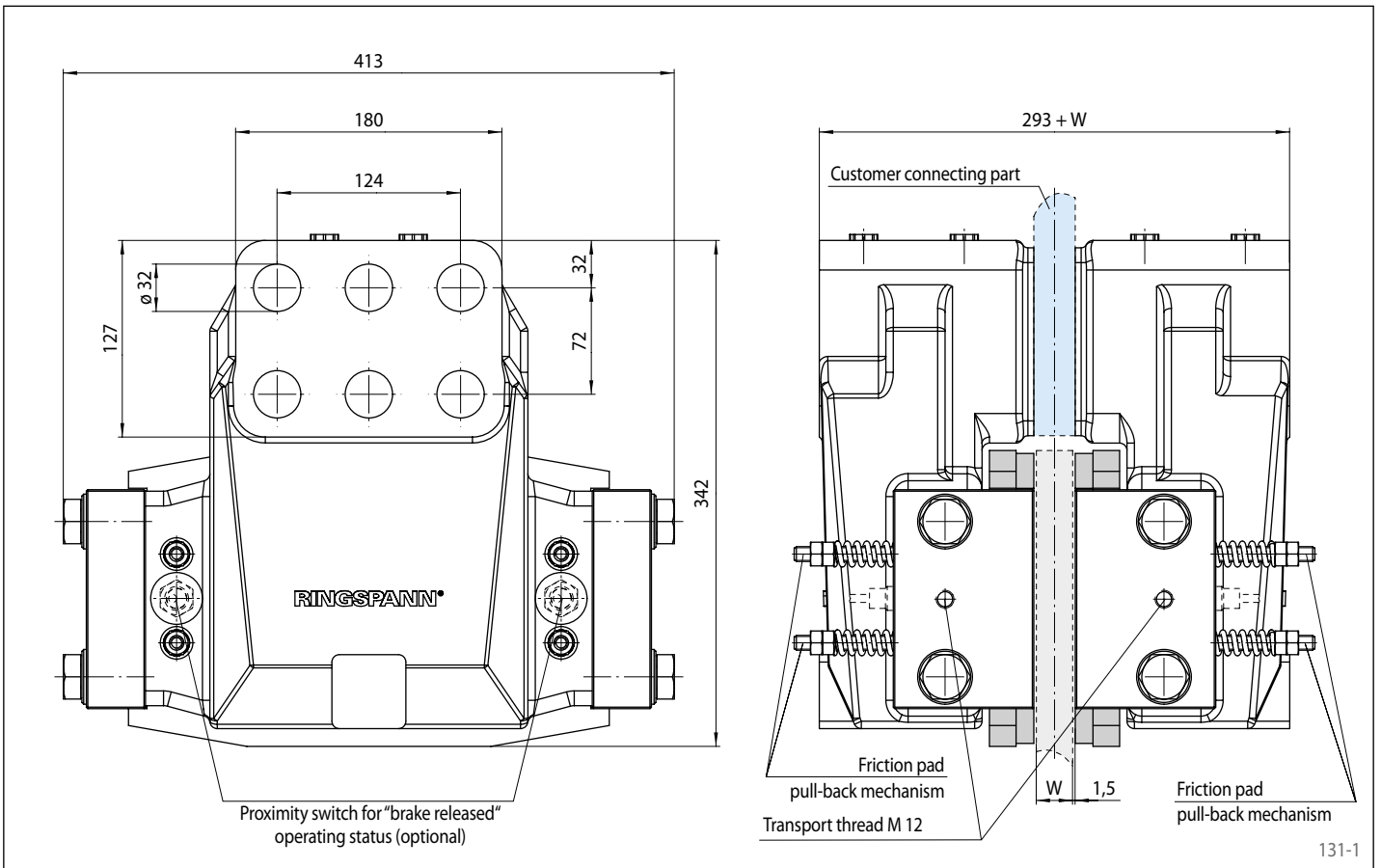

Mounting

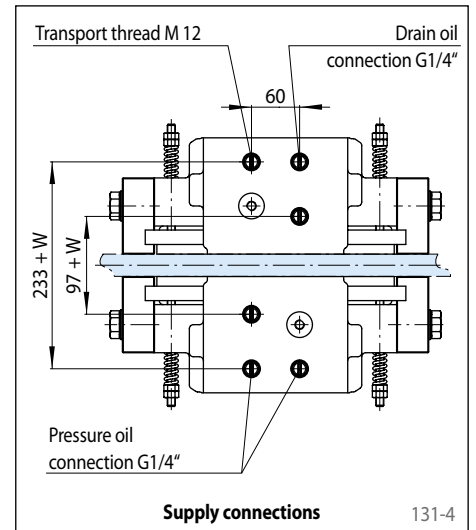
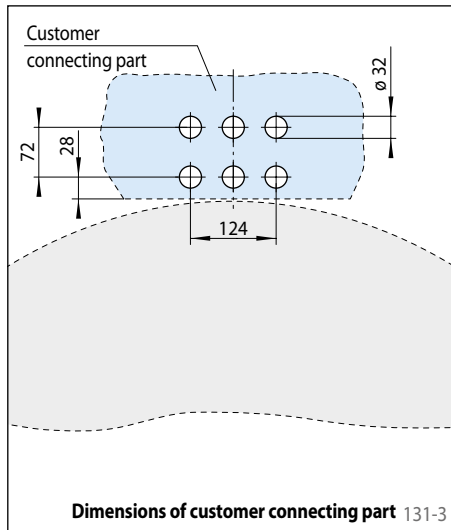
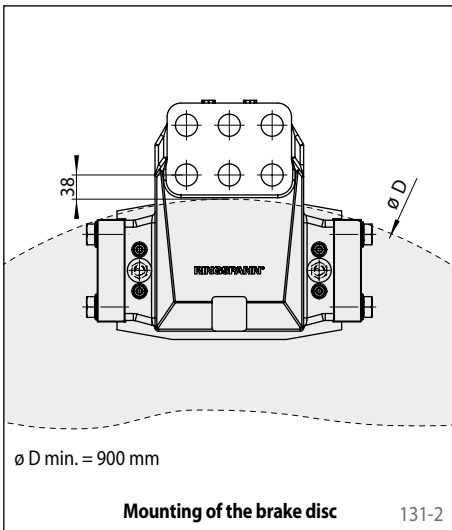

Brake Caliper HW 180 HFA

hydraulically activated – spring released

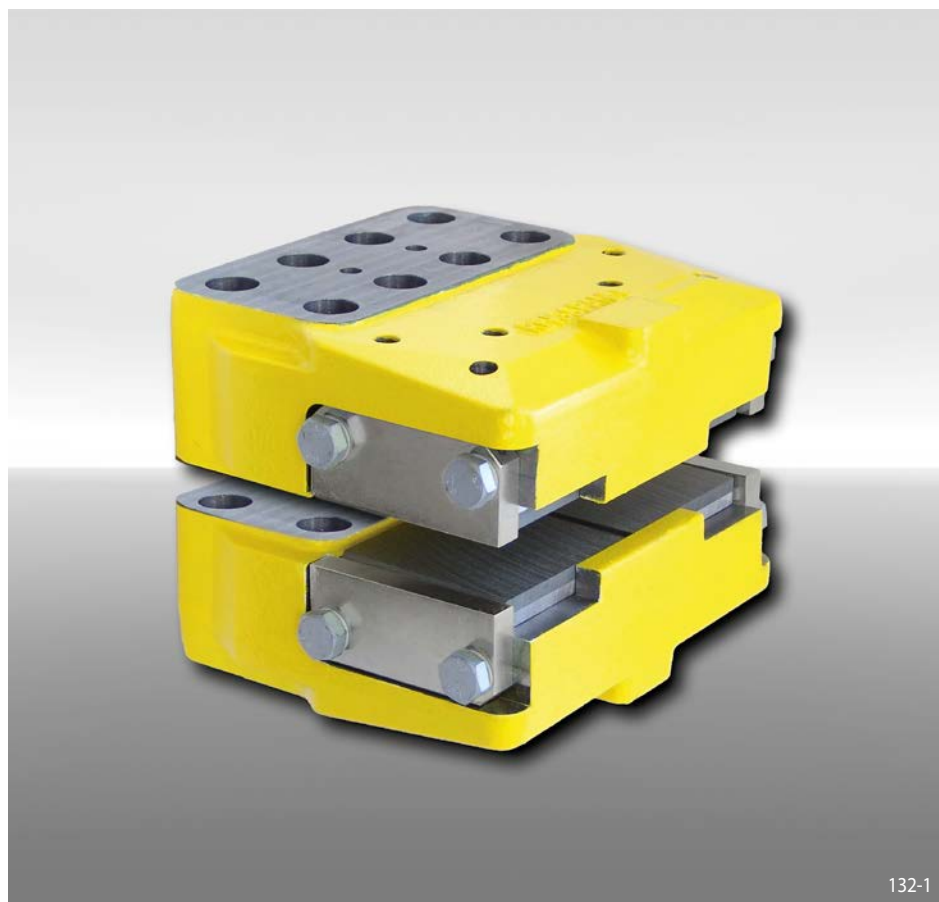

Features	Code
Brake Caliper	H
Standard	W
Frame size 180	180
Hydraulically activated	H
Spring released	F
Automatic adjustment to accommodate friction block wear	A
Max. clamping force 200 kN	200

Example for ordering

Brake Caliper HW 180 HFA, max. clamping force 200 kN:

HW 180 HFA - 200

Technical Data

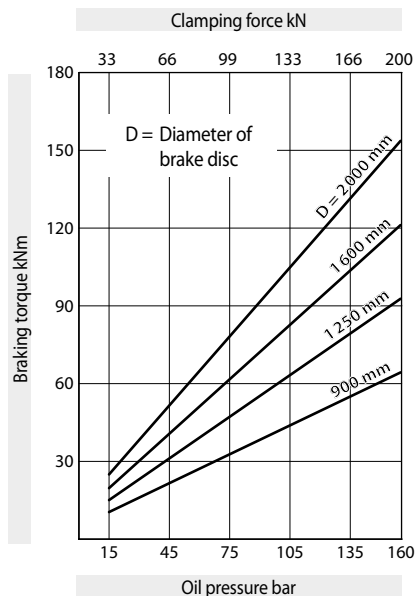

The braking torques shown in the diagram are based on a theoretical friction coefficient of 0,4.

Oil pressure: min. 15 bar
max. 160 bar

Oil volume: max. 190 cm³

Weight: ca. 65 kg

Other features

- High safety against leakage
- Painted with surface coating class C4-L according to ISO 12944
- The thickness of the customer connecting part results from the thickness of the brake disc W

Accessories

- Optional painting with surface coating class C4-H or C5M-H (offshore) according to ISO 12944

Brake Caliper HW 180 HFA

hydraulically activated – spring released

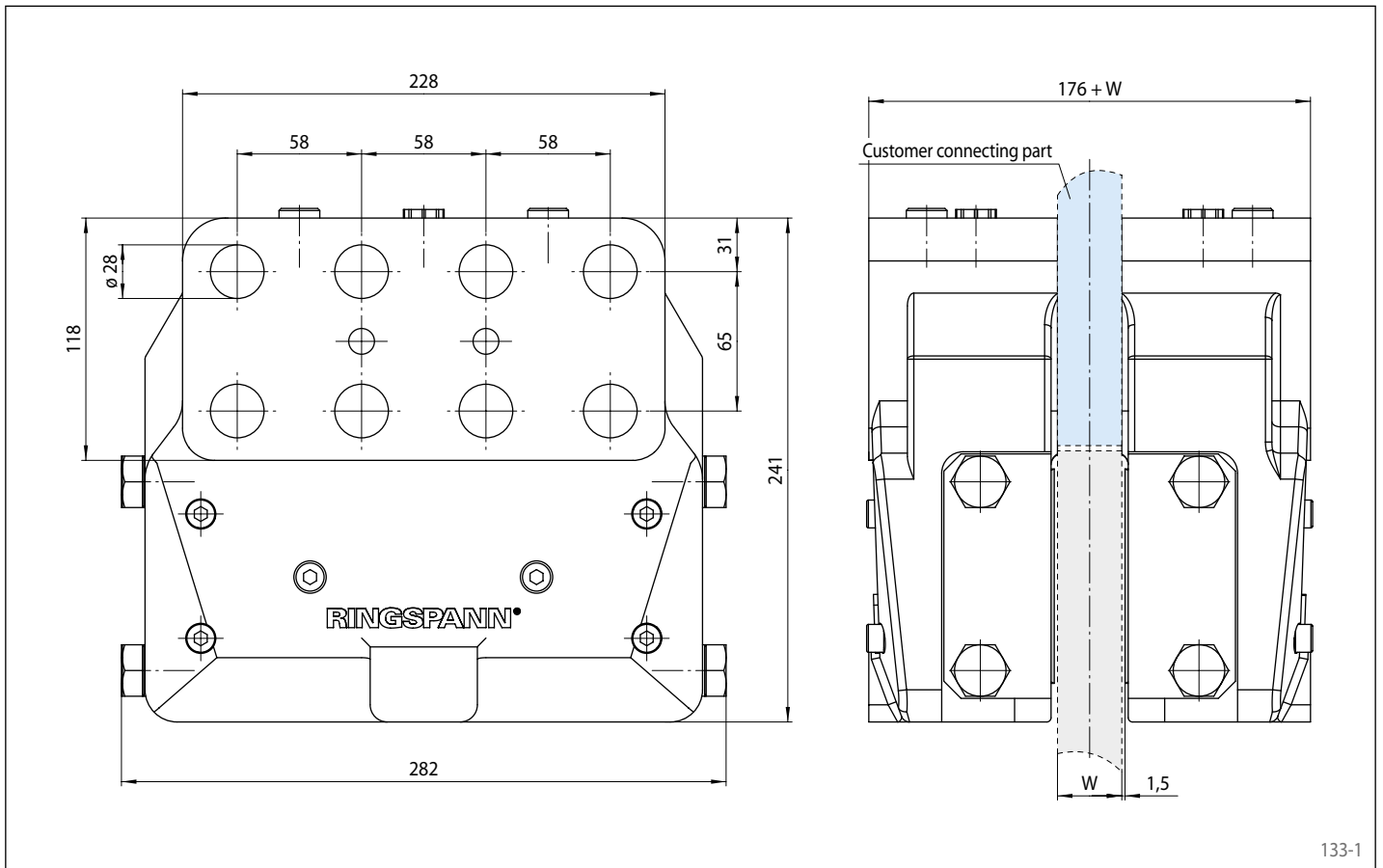

133-1

Mounting

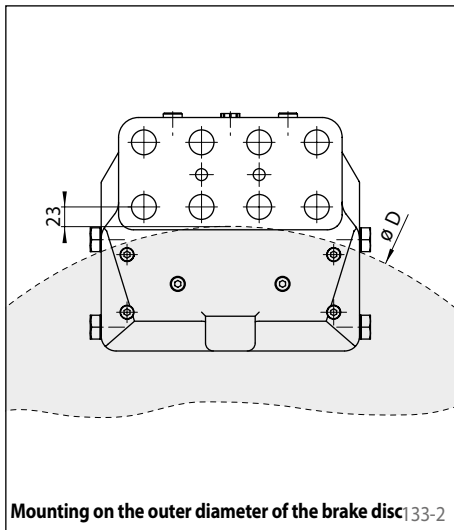

Mounting on the outer diameter of the brake disc 133-2

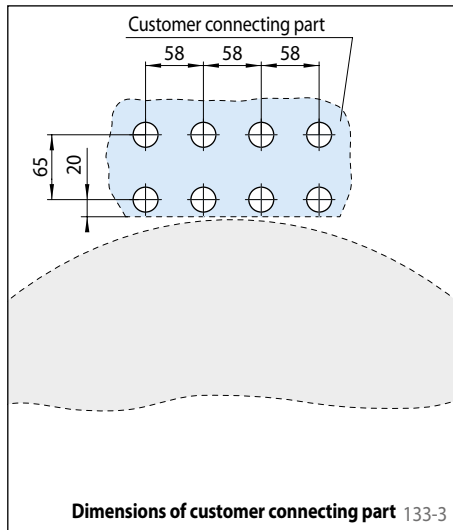

Dimensions of customer connecting part 133-3

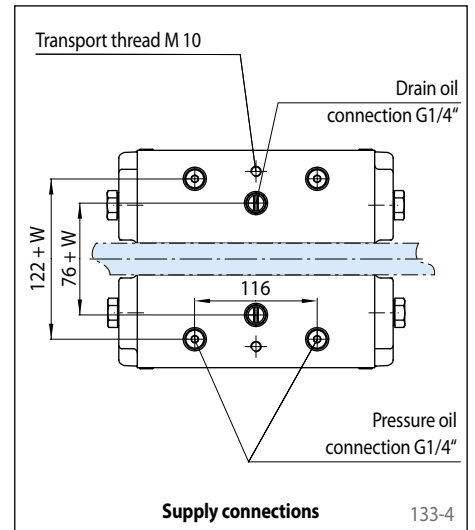

Supply connections

133-4

Brake Caliper DS 160 FEA

spring activated – electrohydraulically released

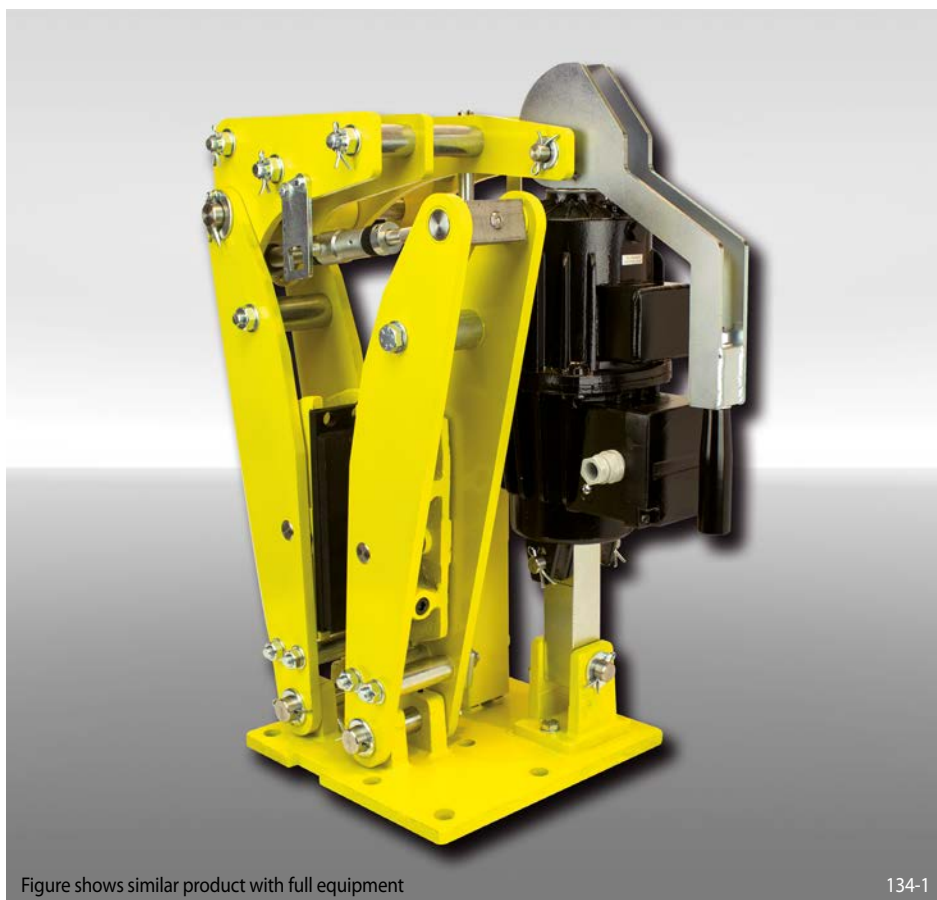

Figure shows similar product with full equipment

134-1

Features	Code
Brake Caliper	D
Disc Brake	S
Frame size 160	160
Spring activated	F
Electrohydraulically released	E
Automatic adjustment to accommodate friction block wear	A
Thrusters 451 or 452 are available	451 452
Thrusters mounted right or left available	R L
Thickness of brake disc 20 mm	20

Example for ordering

Brake Caliper DS 160 FEA, thruster 452, thruster mounted right, thickness of brake disc 20 mm:

DS 160 FEA - 452 R - 20

Technical Data

	Brake Caliper DS 160 FEA	
	with thruster 451	with thruster 452
Brake disc diameter	Braking torque	Braking torque
mm	Nm	Nm
250	200	270
315	260	350
355	300	400
400	340	460
450	390	530
500	440	600
Clamping force	2500 N	3400 N
Braking torque adjustable	20 - 100%	20 - 100%
Nominal power	130 W	180 W
Oil volume	1,4 l	2,5 l
Voltage	230/400 V	230/400 V
Weight	40 kg	45 kg

The braking torques shown in the table are based on a theoretical friction coefficient of 0,4.

Brake Caliper DS 160 FEA

spring activated – electrohydraulically released

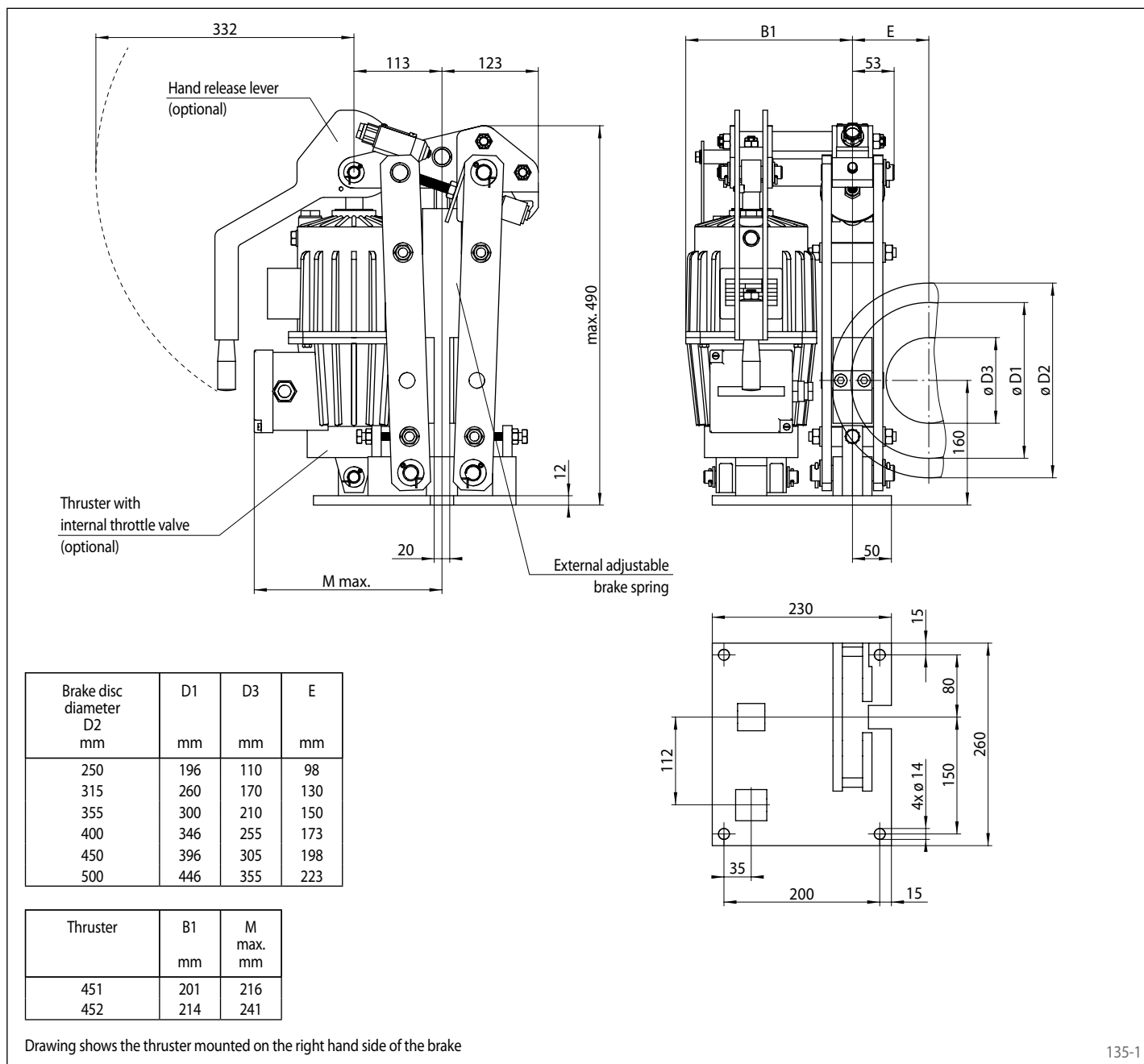

Options

- Micro-switch wear control
- Micro-switch status control
- Micro-switch residual piston stroke warning
- Hand release lever
- Hand release lever with padlock
- Thruster with internal throttle valve
- Thruster in heat resistant design
- Corrosion protected design
- Friction lining of sintered metal
- Pneumatic cylinder instead of thruster
- Thruster also available in other voltages and frequencies

Brake Caliper DS 230 FEM

spring activated – electrohydraulically released

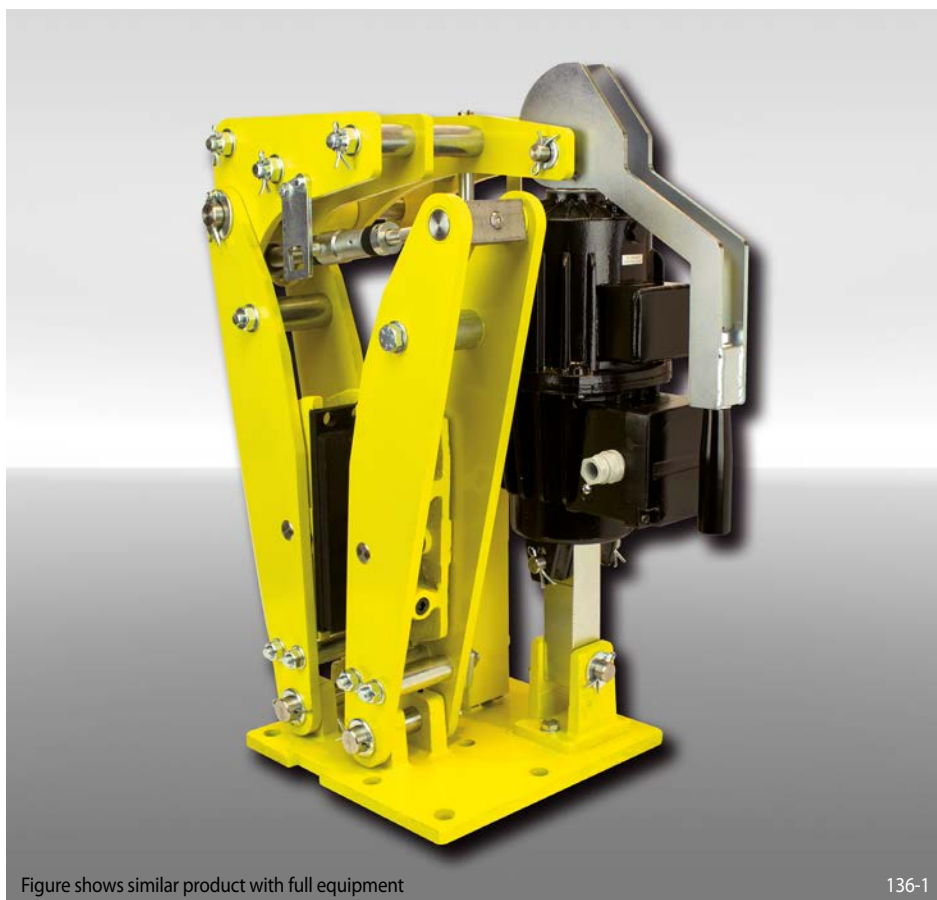

Figure shows similar product with full equipment

136-1

Features	Code
Brake Caliper	D
Disc Brake	S
Frame size 230	230
Spring activated	F
Electrohydraulically released	E
Manual adjustment to accommodate friction block wear	M
Thrusters 451, 452, 453 or 454 are available	451 to 454
Thrusters mounted right or left available	R L
Thickness of brake disc 30 mm	30

Example for ordering

Brake Caliper DS 230 FEM, thruster 453, thruster mounted right, thickness of brake disc 30 mm:

DS 230 FEM - 453 R - 30

Technical Data

	Brake Caliper DS 230 FEM			
	with thruster 451	with thruster 452	with thruster 453	with thruster 454
Brake disc diameter	Braking torque	Braking torque	Braking torque	Braking torque
mm	Nm	Nm	Nm	Nm
315	250	350	750	900
355	300	450	900	1050
400	350	500	1050	1200
450	400	600	1200	1400
500	450	650	1350	1600
Clamping force	2750 N	4100 N	8250 N	9700 N
Braking torque adjustable	20 - 100%	20 - 100%	20 - 100%	20 - 100%
Nominal power	130 W	180 W	240 W	280 W
Oil volume	1,4 l	2,5 l	3,5 l	3,5 l
Voltage	230/400 V	230/400 V	230/400 V	230/400 V
Weight	73 kg	78 kg	80 kg	80 kg

The braking torques shown in the table are based on a theoretical friction coefficient of 0,4.

Brake Caliper DS 230 FEM

spring activated – electrohydraulically released

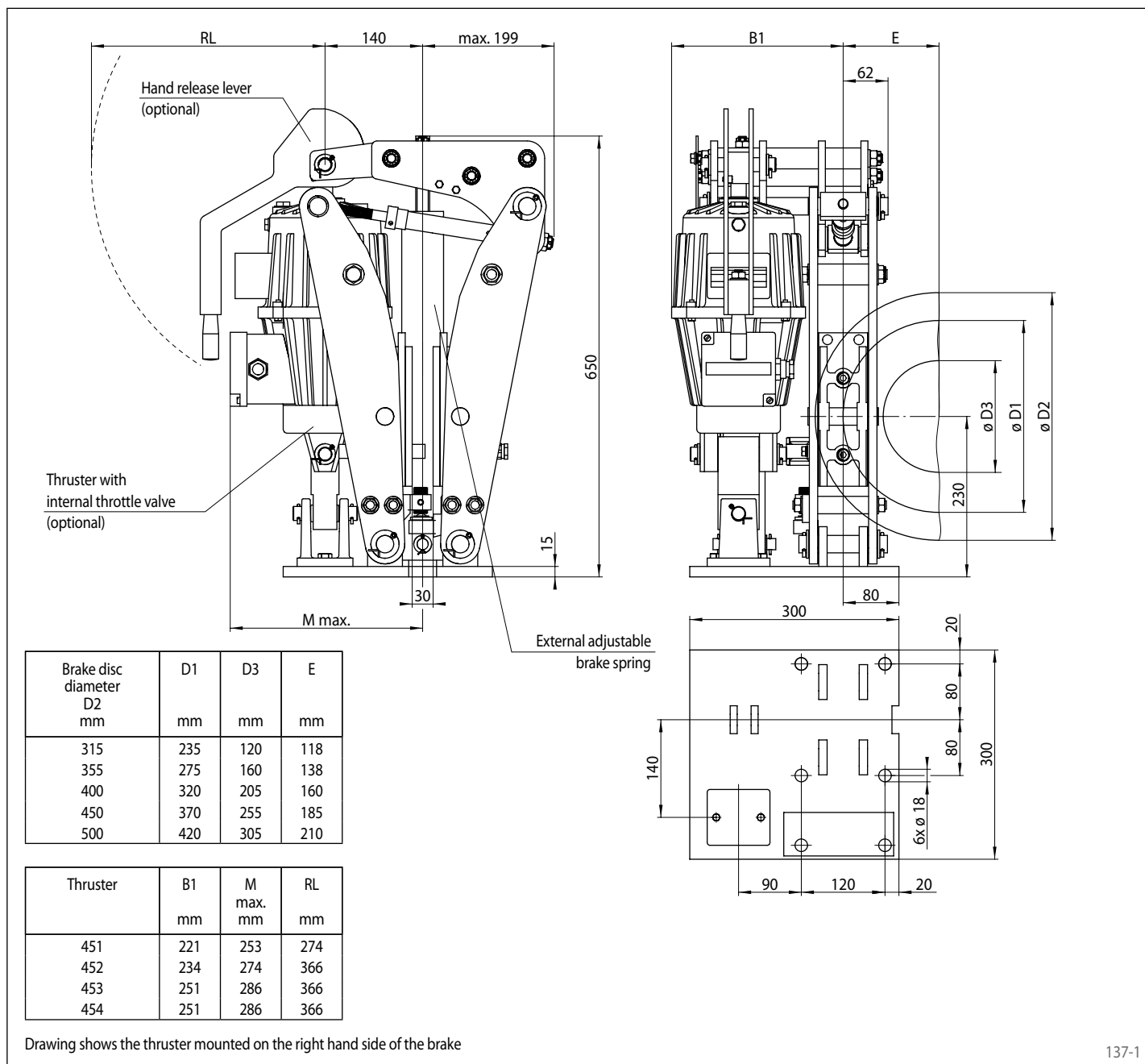

137-1

Options

- Micro-switch wear control
- Micro-switch status control
- Micro-switch residual piston stroke warning
- Hand release lever
- Hand release lever with padlock
- Thruster with internal throttle valve
- Thruster in heat resistant design
- Corrosion protected design
- Friction lining of sintered metal
- Pneumatic cylinder instead of thruster
- Thruster also available in other voltages and frequencies

Brake Caliper DS 230 FEA

spring activated – electrohydraulically released

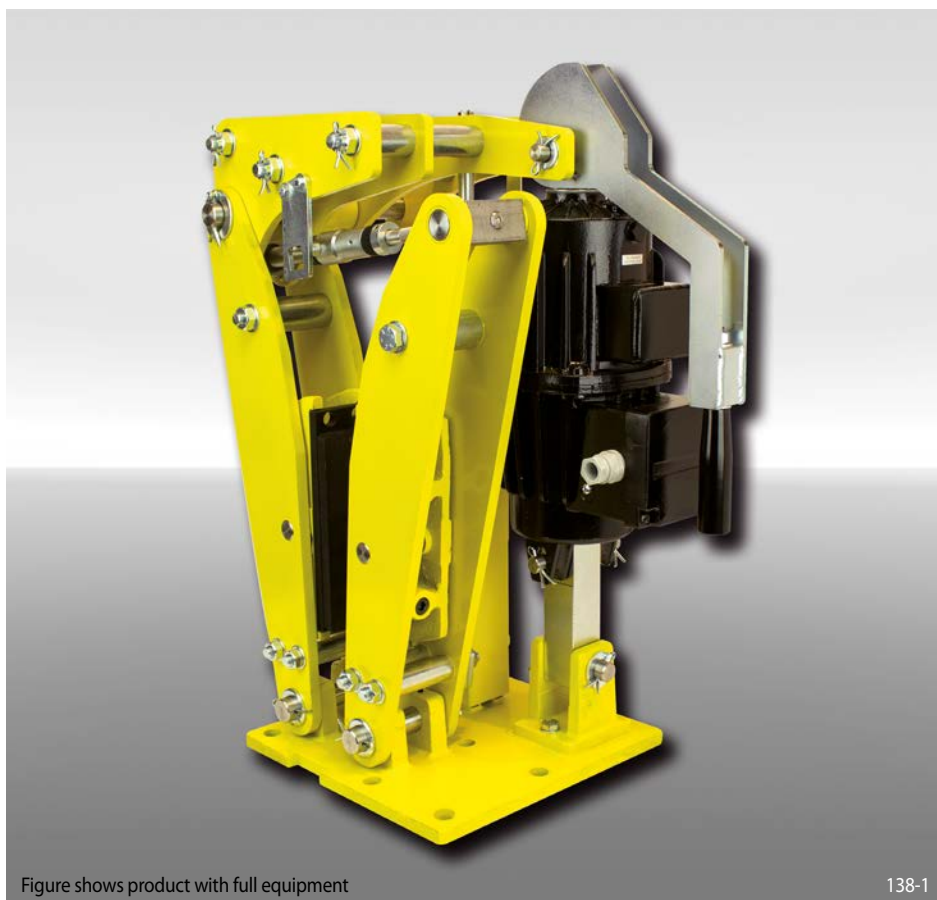

Figure shows product with full equipment

138-1

Features	Code
Brake Caliper	D
Disc Brake	S
Frame size 230	230
Spring activated	F
Electrohydraulically released	E
Automatic adjustment to accommodate friction block wear	A
Thrusters 451, 452, 453 oder 454 are available	451 to 454
Thrusters mounted right or left available	R L
Thickness of brake disc 30 mm	30

Example for ordering

Brake Caliper DS 230 FEA, thruster 453, thruster mounted right, thickness of brake disc 30 mm:

DS 230 FEA - 453 R - 30

Technical Data

	Brake Caliper DS 230 FEA			
	with thruster 451	with thruster 452	with thruster 453	with thruster 454
Brake disc diameter	Braking torque	Braking torque	Braking torque	Braking torque
mm	Nm	Nm	Nm	Nm
315	250	350	750	900
355	300	450	900	1050
400	350	500	1050	1200
450	400	600	1200	1400
500	450	650	1350	1600
Clamping force	2750 N	4100 N	8250 N	9700 N
Braking torque adjustable	20 - 100%	20 - 100%	20 - 100%	20 - 100%
Nominal power	130 W	180 W	240 W	280 W
Oil volume	1,4 l	2,5 l	3,5 l	3,5 l
Voltage	230/400 V	230/400 V	230/400 V	230/400 V
Weight	73 kg	78 kg	80 kg	80 kg

The braking torques shown in the table are based on a theoretical friction coefficient of 0,4.

Brake Caliper DS 230 FEA

spring activated – electrohydraulically released

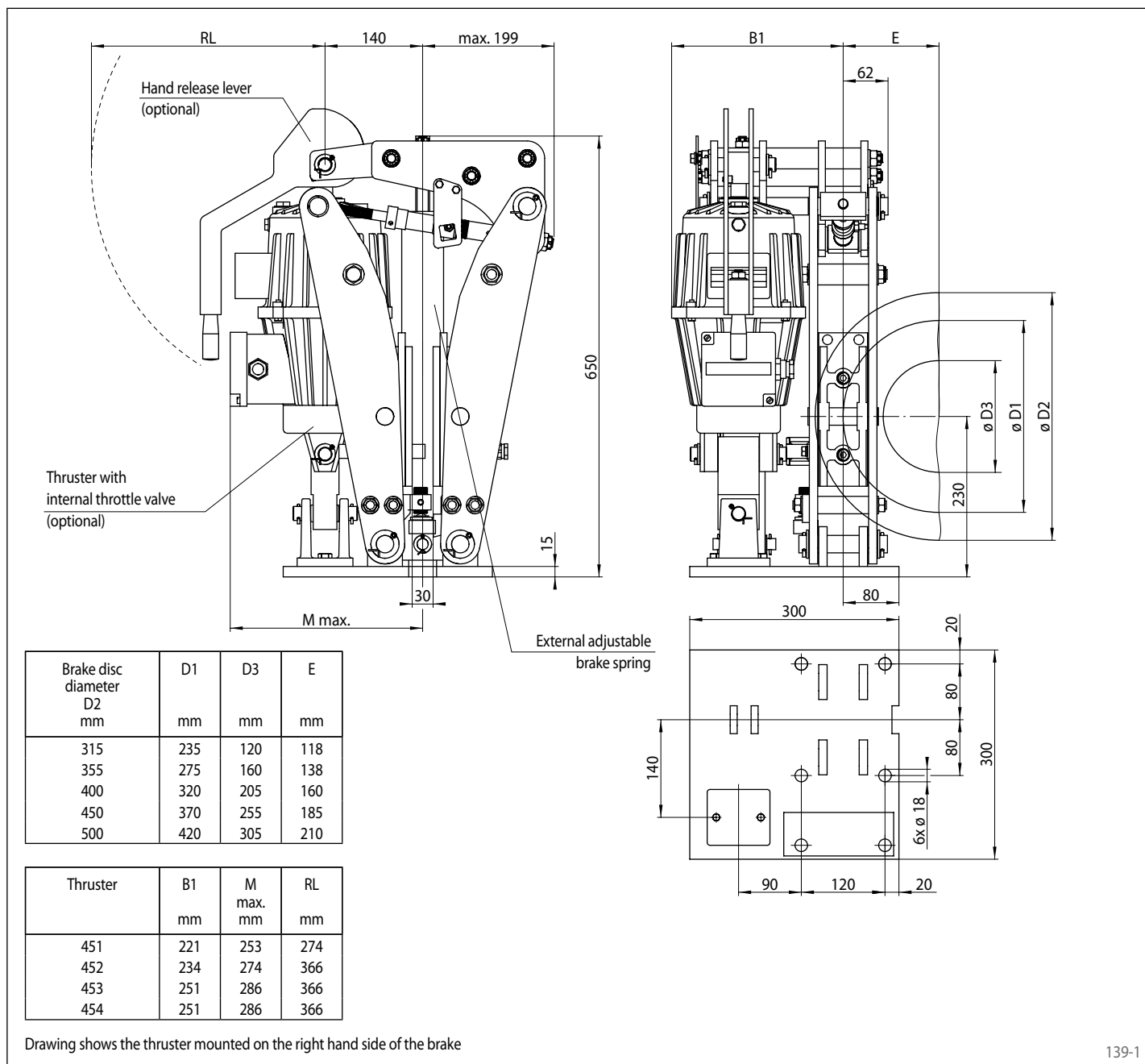

139-1

Options

- Micro-switch wear control
- Micro-switch status control
- Micro-switch residual piston stroke warning
- Hand release lever
- Hand release lever with padlock
- Thruster with internal throttle valve
- Thruster in heat resistant design
- Corrosion protected design
- Friction lining of sintered metal
- Pneumatic cylinder instead of thruster
- Thruster also available in other voltages and frequencies

Brake Caliper DX 230 FEA

spring activated – electrohydraulically released



Features	Code
Brake Caliper	D
Disc Brake	X
Frame size 230	230
Spring activated	F
Electrohydraulically released	E
Automatic adjustment to accommodate friction block wear	A
Thrusters 454, 455, 465 or 475 are available	454 to 475

Example for ordering

Disc Brake DX 230 FEA, thruster 455:

DX 230 FEA - 455

Technical Data

Brake disc diameter mm	Brake Caliper DX 230 FEA							
	with thruster 454		with thruster 455		with thruster 465		with thruster 475 C	
	Braking torque		Braking torque		Braking torque		Braking torque	
	min. Nm	max. Nm	min. Nm	max. Nm	min. Nm	max. Nm	min. Nm	max. Nm
355	400	960	650	1 670	800	2 150	950	2 600
400	470	1 130	770	1 970	950	2 550	1 100	3 050
450	550	1 320	900	2 300	1 100	3 000	1 300	3 550
500	630	1 510	1 030	2 650	1 250	3 400	1 500	4 050
560	730	1 740	1 190	3 030	1 450	3 950	1 700	4 650
630	840	2 000	1 370	3 450	1 650	4 550	2 000	5 400
710	970	2 310	1 580	4 020	1 950	5 200	2 300	6 200
Clamping force	9 500 N		16 500 N		21 500 N		25 500 N	
Push force thruster	750 N		1 200 N		1 500 N		1 750 N	
Weight of thruster	15 kg		21 kg		21 kg		31 kg	
Weight of brake without thruster	95 kg		95 kg		95 kg		105 kg	

The braking torques shown in the table are based on a theoretical friction coefficient of 0,4. Braking torques are based on optimum conditioned friction partners.

Technical description

The RINGSPANN DX brakes are mainly used as holding or emergency stop brakes at high circumferential speeds and a high number of switching cycles.

When the power supply is switched off or in the event of a power failure, the brakes close automatically by spring force. The brakes are opened with the help of an electrohydraulic thruster.

Typical applications are hoists and travel drives for cranes, conveyor belt and bucket wheel drives.

Brake Caliper DX 230 FEA

RINGSPANN®

spring activated – electrohydraulically released

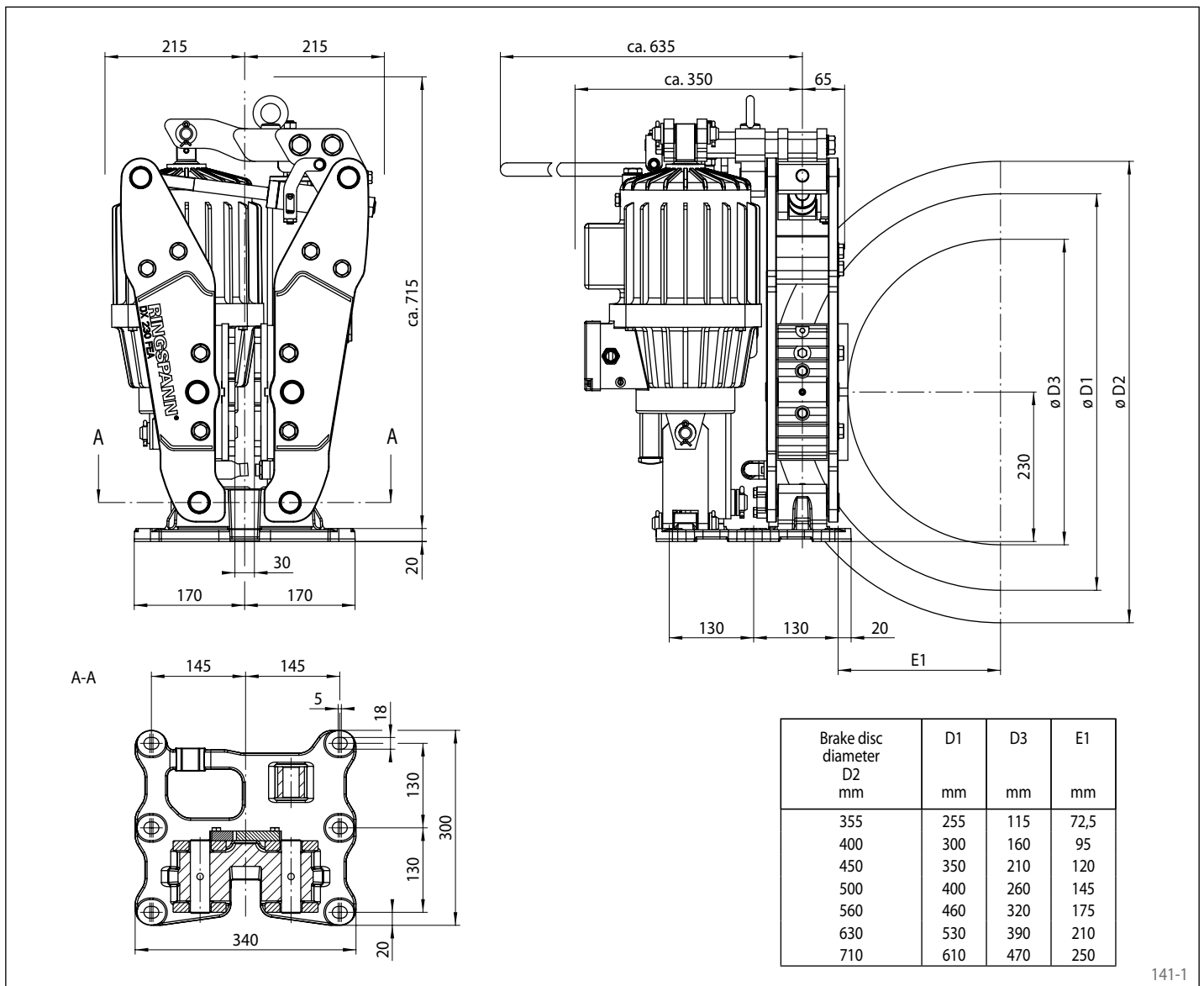

141-1

Other features

- Maintenance-friendly steel lever design
- Easy and robust brake alignment and adjustment
- Automatic wear compensation unit
- Self-centering device for equal air gap on both sides between brake lining and brake disc
- Parallel air gap with brake open
- Bolts and tension rods made of stainless steel
- Maintenance free self-lubricating bushings
- Continuous adjustable spring tube unit
- Asbestos free sinter brake linings
- Ambient temperature: -20° to +70° C
- Standard power connection: 3-phase 400VAC/50Hz

Options

- Switching sensors for status signals: "brake open", "brake closed", "brake lining wear limit" and "manual release activated"
- Linear position sensor for monitoring the opening and reserve stroke
- PT100 temperature sensors for monitoring the brake lining temperature
- DMS load measuring cell for monitoring the clamping force
- Terminal box for sensor connection
- Eccentric manual release
- Maritime version (C5-M/CX)
- Special versions for low or high ambient temperatures
- Thrusters with internal lifting and lowering valves
- Thrusters in explosion-proof design
- Power connections 3-phase 200-800VAC 50/60Hz
- Other brake disc thicknesses on request

Brake Caliper DS 280 FEM

spring activated – electrohydraulically released

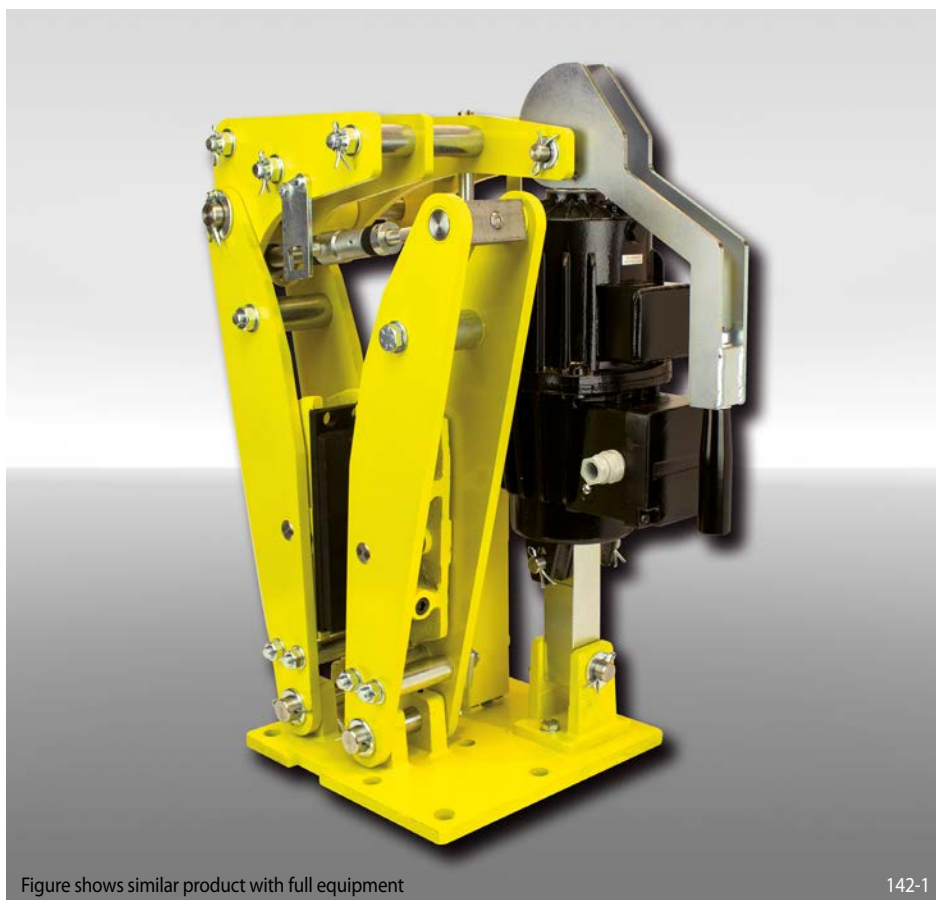

Figure shows similar product with full equipment

142-1

Features	Code
Brake Caliper	D
Disc Brake	S
Frame size 280	280
Spring activated	F
Electrohydraulically released	E
Manual adjustment to accommodate friction block wear	M
Thrusters 453, 454, 455 or 456 are available	453 to 456
Thrusters mounted right or left available	R L
Thickness of brake disc 30 mm	30

Example for ordering

Brake Caliper DS 280 FEM, thruster 456, thruster mounted right, thickness of brake disc 30 mm:

DS 280 FEM - 456 R - 30

Technical Data

	Brake Caliper DS 280 FEM			
	with thruster 453	with thruster 454	with thruster 455	with thruster 456
Brake disc diameter	Braking torque	Braking torque	Braking torque	Braking torque
mm	Nm	Nm	Nm	Nm
400	1200	1450	2400	3950
450	1400	1700	2800	4650
500	1600	1950	3200	5300
560	1850	2250	3650	6100
630	2100	2600	4250	7050
710	2450	3000	4850	8100
Clamping force	10050 N	12250 N	20050 N	33250 N
Braking torque adjustable	20 - 100%	20 - 100%	20 - 100%	20 - 100%
Nominal power	240 W	280 W	370 W	590 W
Oil volume	3,5 l	3,5 l	4,5 l	11 l
Voltage	230/400 V	230/400 V	230/400 V	230/400 V
Weight	126 kg	126 kg	132 kg	158 kg

The braking torques shown in the table are based on a theoretical friction coefficient of 0,4.

Brake Caliper DS 280 FEM

spring activated – electrohydraulically released

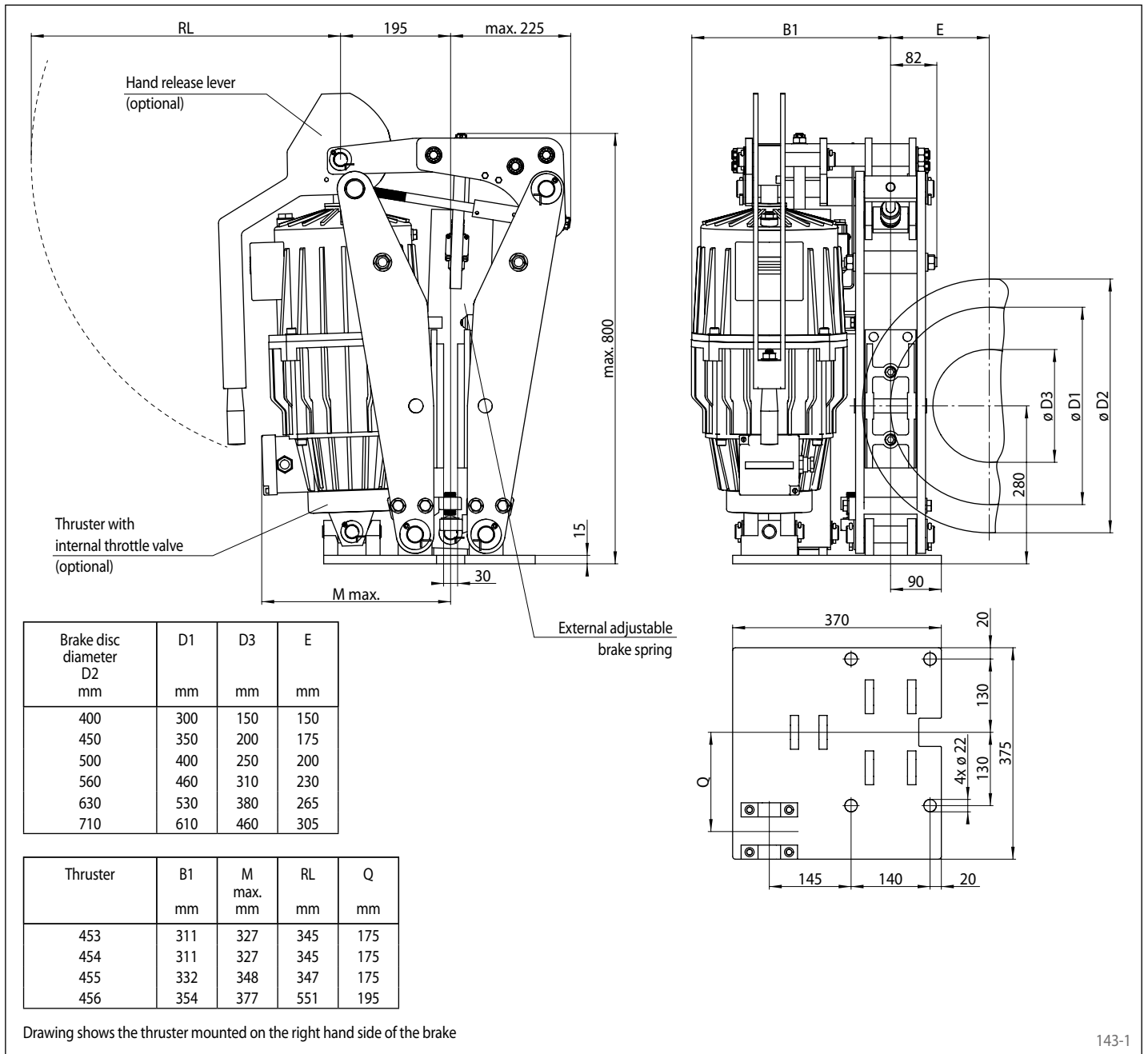

143-1

Options

- Micro-switch wear control
- Micro-switch status control
- Micro-switch residual piston stroke warning
- Hand release lever
- Hand release lever with padlock
- Thruster with internal throttle valve
- Thruster in heat resistant design
- Corrosion protected design
- Friction lining of sintered metal
- Pneumatic cylinder instead of thruster
- Thruster also available in other voltages and frequencies

Brake Caliper DS 280 FEA

spring activated – electrohydraulically released

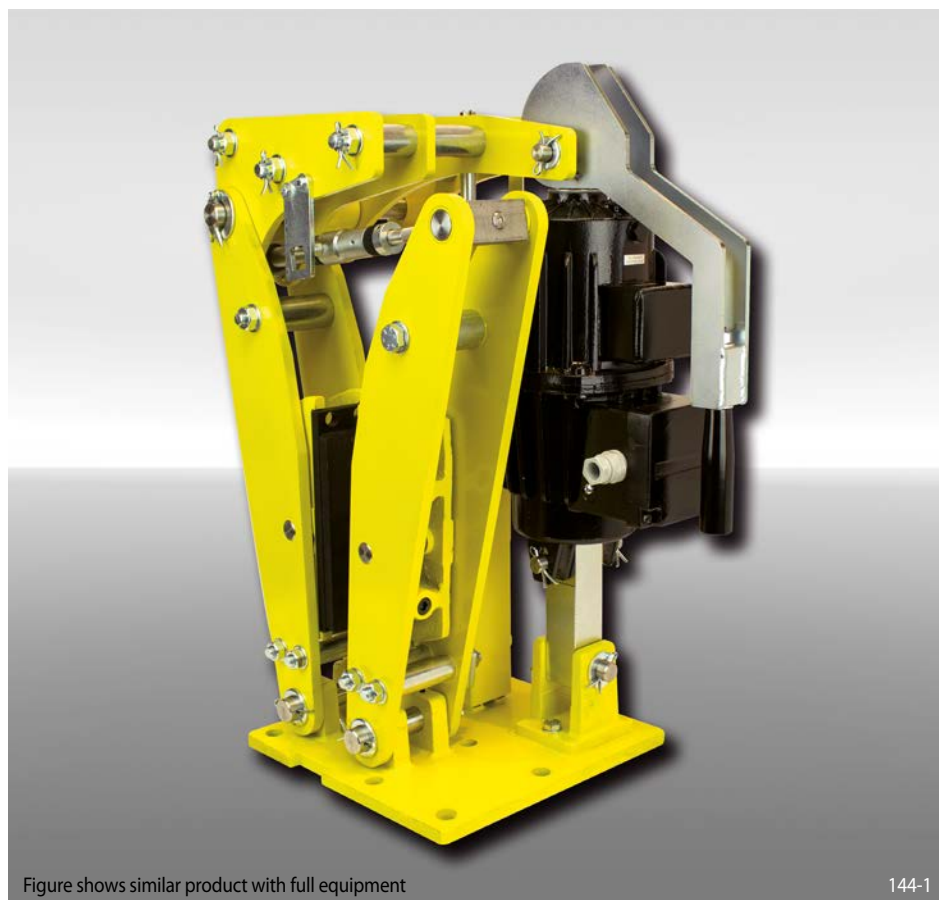

Figure shows similar product with full equipment

144-1

Features	Code
Brake Caliper	D
Disc Brake	S
Frame size 280	280
Spring activated	F
Electrohydraulically released	E
Automatic adjustment to accommodate friction block wear	A
Thrusters 453, 454, 455 or 456 are available	453 to 456
Thrusters mounted right or left available	R L
Thickness of brake disc 30 mm	30

Example for ordering

Brake Caliper DS 280 FEA, thruster 456, thruster mounted right, thickness of brake disc 30 mm:

DS 280 FEA - 456 R - 30

Technical Data

	Brake Caliper DS 280 FEA			
	with thruster 453	with thruster 454	with thruster 455	with thruster 456
Brake disc diameter	Braking torque	Braking torque	Braking torque	Braking torque
mm	Nm	Nm	Nm	Nm
400	1200	1450	2400	3950
450	1400	1700	2800	4650
500	1600	1950	3200	5300
560	1850	2250	3650	6100
630	2100	2600	4250	7050
710	2450	3000	4850	8100
Clamping force	10050 N	12250 N	20050 N	33250 N
Braking torque adjustable	20 - 100%	20 - 100%	20 - 100%	20 - 100%
Nominal power	240 W	280 W	370 W	590 W
Oil volume	3,5 l	3,5 l	4,5 l	11 l
Voltage	230/400 V	230/400 V	230/400 V	230/400 V
Weight	126 kg	126 kg	132 kg	158 kg

The braking torques shown in the table are based on a theoretical friction coefficient of 0,4.

Brake Caliper DS 280 FEA

spring activated – electrohydraulically released

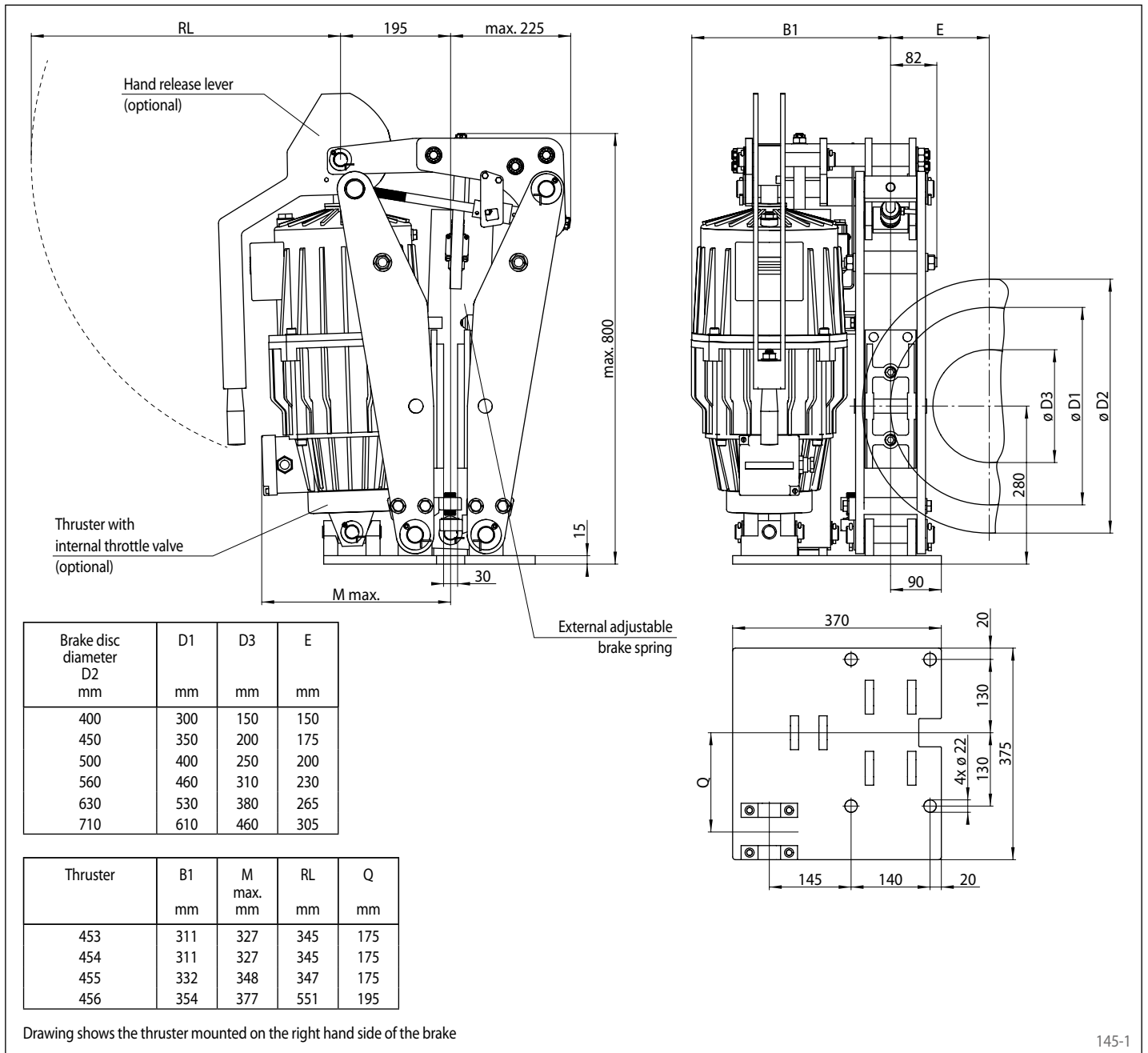

145-1

Options

- Micro-switch wear control
- Micro-switch status control
- Micro-switch residual piston stroke warning
- Hand release lever
- Hand release lever with padlock
- Thruster with internal throttle valve
- Thruster in heat resistant design
- Corrosion protected design
- Friction lining of sintered metal
- Pneumatic cylinder instead of thruster
- Thruster also available in other voltages and frequencies

Brake Caliper DX 280 FEA

spring activated – electrohydraulically released



Features	Code
Brake Caliper	D
Disc Brake	X
Frame size 280	280
Spring activated	F
Electrohydraulically released	E
Automatic adjustment to accommodate friction block wear	A
Thrusters 459, 463, 464 or 475 are available	459 to 475
Thruster 475 is optionally available with a push force of 4 500 N (H) or 5 500 N (J)	H J

Example for ordering

Disc Brake DX 280 FEA, thruster 459:

DX 280 FEA - 459

Technical Data

Brake disc diameter mm	Brake Caliper DX 280 FEA									
	with thruster 459		with thruster 464		with thruster 463		with thruster 475 H		with thruster 475 J	
	Braking torque		Braking torque		Braking torque		Braking torque		Braking torque	
	min. Nm	max. Nm	min. Nm	max. Nm	min. Nm	max. Nm	min. Nm	max. Nm	min. Nm	max. Nm
500	1700	3400	3000	6000	-	-	-	-	-	-
560	1900	3900	3500	7000	-	-	-	-	-	-
630	2200	4500	4000	8100	-	-	-	-	-	-
710	2600	5300	4700	9400	7600	15300	1400	15300	9400	18800
800	3000	6100	5400	10800	8800	17600	1600	17600	10800	21700
900	3500	7000	6200	12400	10100	20200	1800	20200	12400	24900
1000	3900	7900	7000	14000	11400	22800	2100	22800	14000	28100
Clamping force	22500 N		40000 N		65000 N		65000 N		80000 N	
Push force thruster	2000 N		3000 N		4500 N		4500 N*		5500 N*	
Weight of thruster	52 kg		52 kg		52 kg		31 kg		31 kg	
Weight of brake without thruster	220 kg		220 kg		220 kg		220 kg		235 kg	

The braking torques shown in the table are based on a theoretical friction coefficient of 0,4. Braking torques are based on optimum conditioned friction partners.
* adjusted to nominal value

Technical description

The RINGSPANN DX brakes are mainly used as holding or emergency stop brakes at high circumferential speeds and a high number of switching cycles.

When the power supply is switched off or in the event of a power failure, the brakes close automatically by spring force. The brakes are opened with the help of an electrohydraulic thruster.

Typical applications are hoists and travel drives for cranes, conveyor belt and bucket wheel drives.

Brake Caliper DX 280 FEA

spring activated – electrohydraulically released

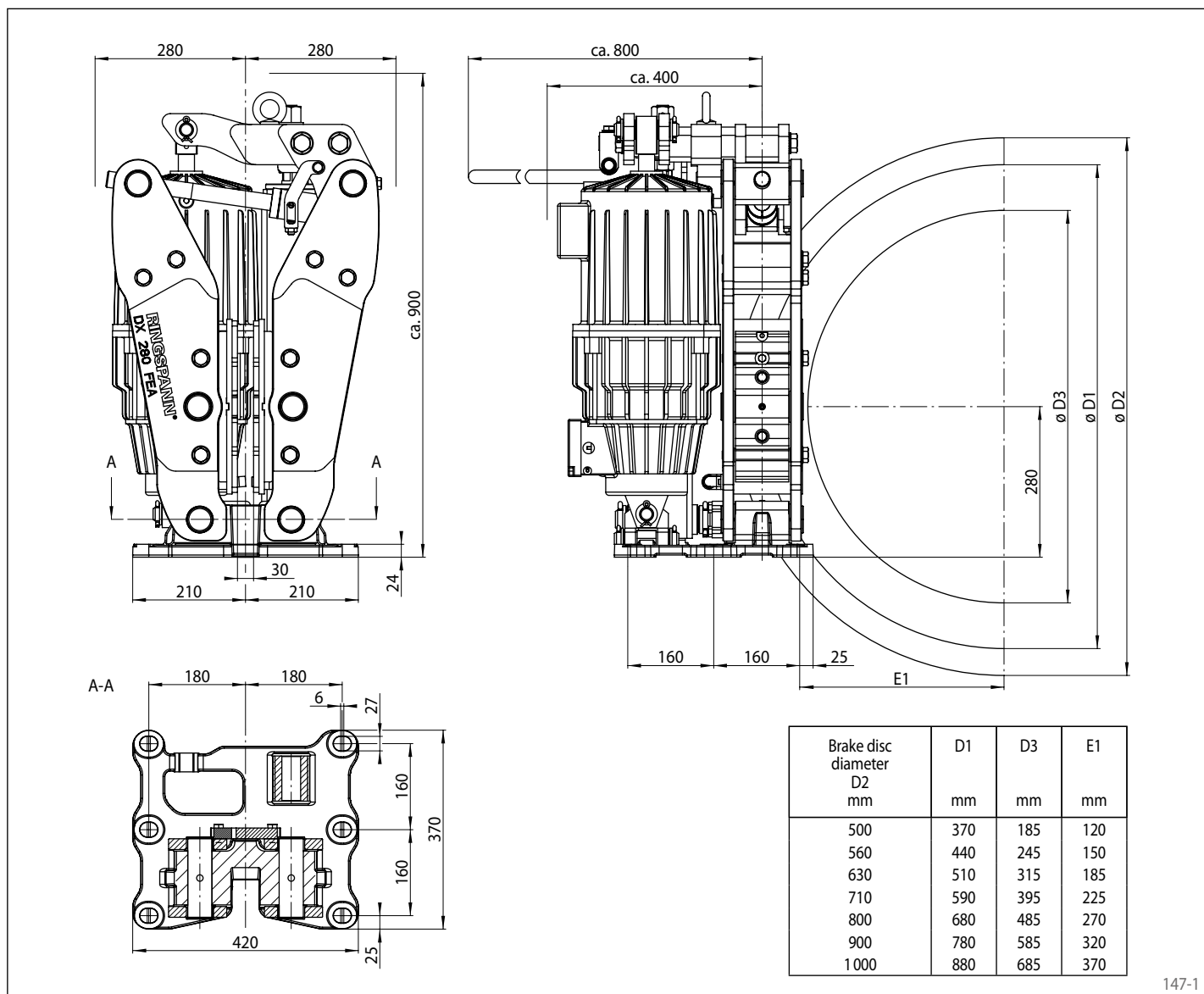

147-1

Other features

- Maintenance-friendly steel lever design
- Easy and robust brake alignment and adjustment
- Automatic wear compensation unit
- Self-centering device for equal air gap on both sides between brake lining and brake disc
- Parallel air gap with brake open
- Bolts and tension rods made of stainless steel
- Maintenance free self-lubricating bushings
- Continuous adjustable spring tube unit
- Asbestos free sinter brake linings
- Ambient temperature: -20° to +70° C
- Standard power connection: 3-phase 400VAC/50Hz

Options

- Switching sensors for status signals: "brake open", "brake closed", "brake lining wear limit" and "manual release activated"
- Linear position sensor for monitoring the opening and reserve stroke
- PT100 temperature sensors for monitoring the brake lining temperature
- DMS load measuring cell for monitoring the clamping force
- Terminal box for sensor connection
- Eccentric manual release
- Maritime version (C5-M/CX)
- Special versions for low or high ambient temperatures
- Thrusters with internal lifting and lowering valves
- Thrusters in explosion-proof design
- Power connections 3-phase 200-800VAC 50/60Hz
- Other brake disc thicknesses on request

Brake Caliper DS 370 FEM

spring activated – electrohydraulically released

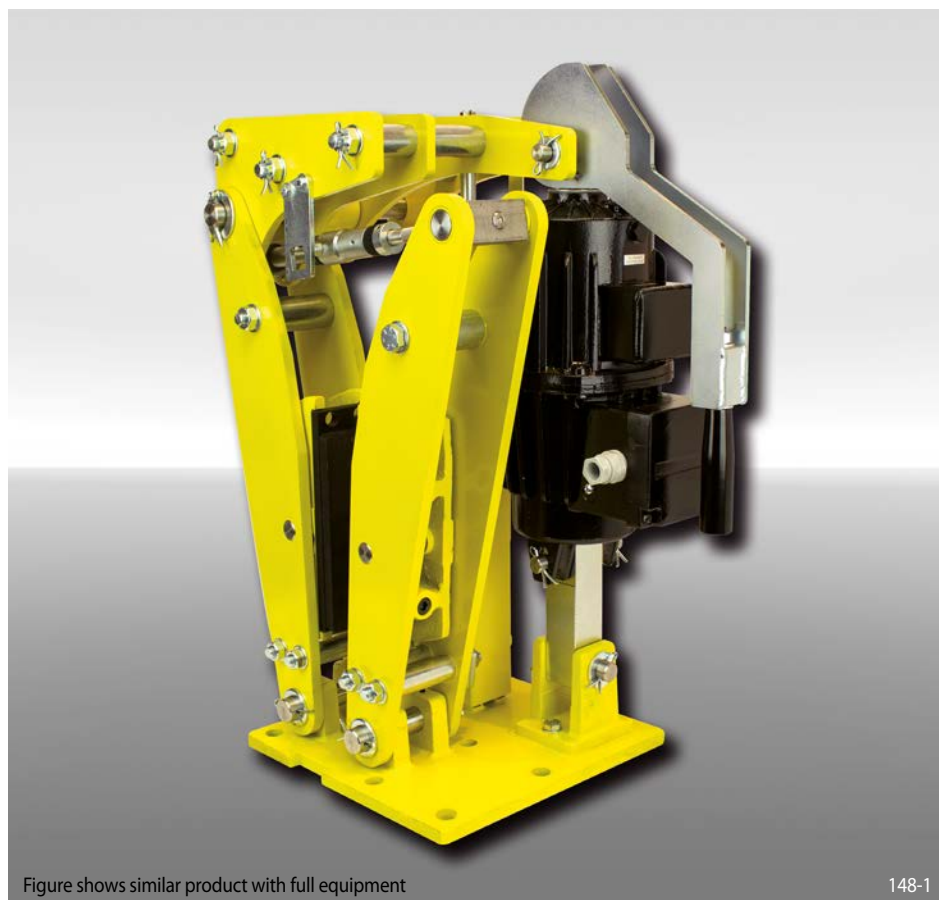

Figure shows similar product with full equipment

148-1

Features	Code
Brake Caliper	D
Disc Brake	S
Frame size 370	370
Spring activated	F
Electrohydraulically released	E
Manual adjustment to accommodate friction block wear	M
Thrusters 455, 456 or 457 are available	455 456 457
Thrusters mounted right or left available	R L
Thickness of brake disc 30 mm	30

Example for ordering

Brake Caliper DS 370 FEM, thruster 456, thruster mounted right, thickness of brake disc 30 mm:

DS 370 FEM - 456 R - 30

Technical Data

	Brake Caliper DS 370 FEM		
	with thruster 455	with thruster 456	with thruster 457
Brake disc diameter	Braking torque	Braking torque	Braking torque
mm	Nm	Nm	Nm
500	2950	5000	7400
560	3450	5800	8600
630	4000	6750	10000
710	4550	7850	11600
800	5350	9050	13400
900	6200	10400	15400
1000	7000	11750	17400
1250	9000	15000	22400
Clamping force	20100 N	33850 N	50000 N
Braking torque adjustable	20 - 100%	20 - 100%	20 - 100%
Nominal power	370 W	590 W	680 W
Oil volume	4,5 l	11 l	11 l
Voltage	230/400 V	230/400 V	230/400 V
Weight	241 kg	267 kg	267 kg

The braking torques shown in the table are based on a theoretical friction coefficient of 0,4.

Brake Caliper DS 370 FEM

spring activated – electrohydraulically released

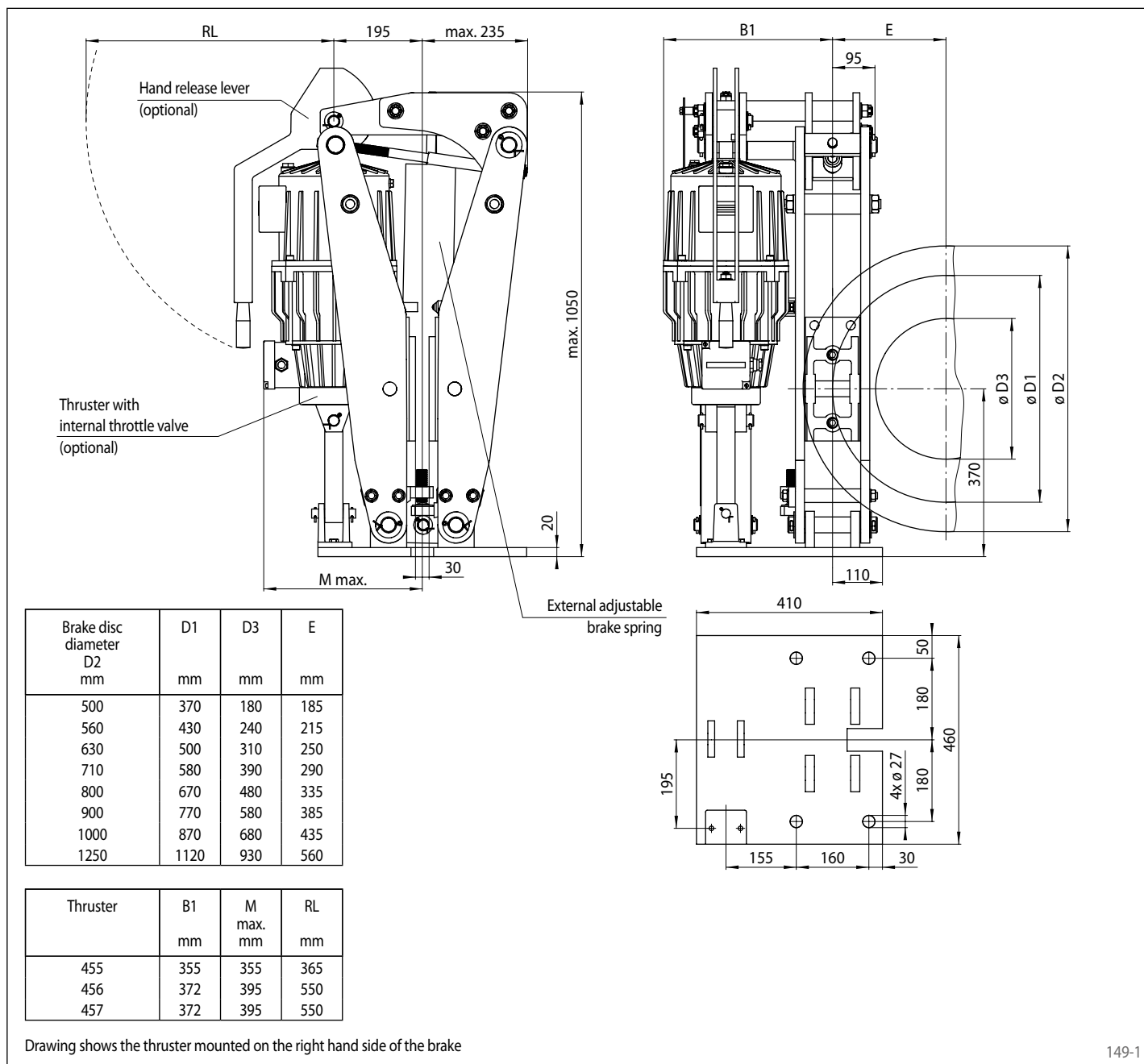

149-1

Options

- Micro-switch wear control
- Micro-switch status control
- Micro-switch residual piston stroke warning
- Hand release lever
- Hand release lever with padlock
- Thruster with internal throttle valve
- Thruster in heat resistant design
- Corrosion protected design
- Friction lining of sintered metal
- Pneumatic cylinder instead of thruster
- Thruster also available in other voltages and frequencies

Brake Caliper DS 370 FEA

spring activated – electrohydraulically released

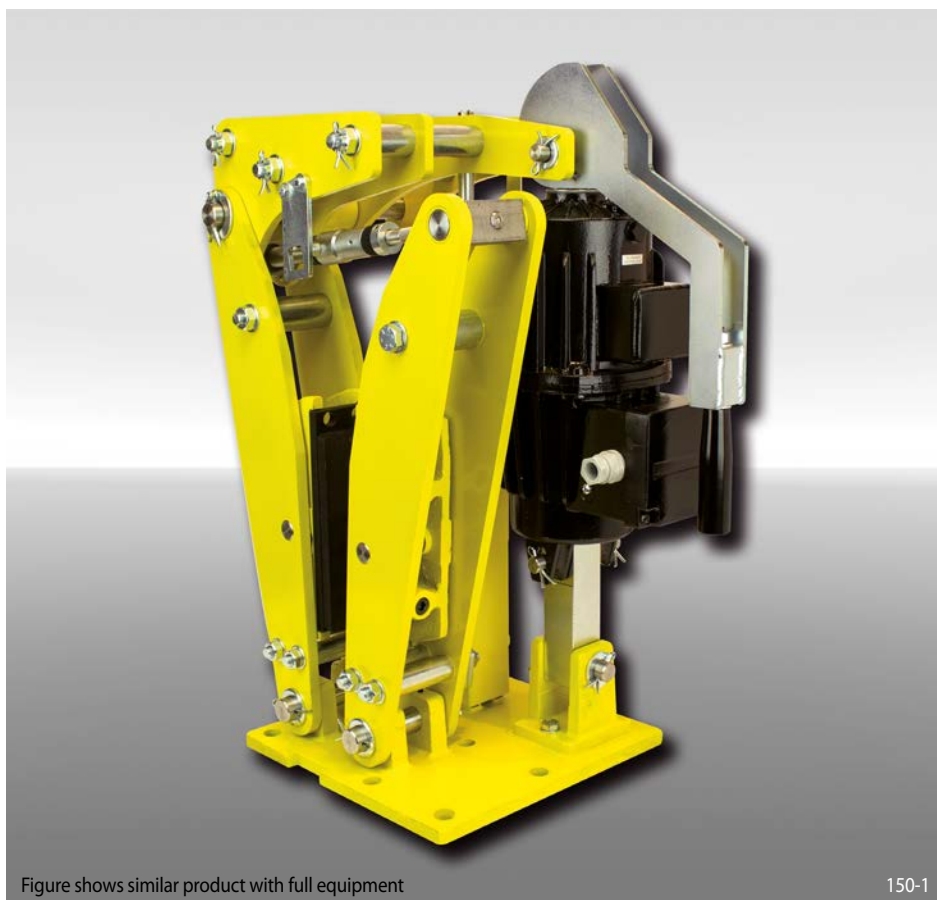

Figure shows similar product with full equipment

150-1

Features	Code
Brake Caliper	D
Disc Brake	S
Frame size 370	370
Spring activated	F
Electrohydraulically released	E
Automatic adjustment to accommodate friction block wear	A
Thrusters 455, 456 or 457 are available	455 456 457
Thrusters mounted right or left available	R L
Thickness of brake disc 30 mm	30

Example for ordering

Brake Caliper DS 370 FEA, thruster 456, thruster mounted right, thickness of brake disc 30 mm:

DS 370 FEA - 456 R - 30

Technical Data

	Brake Caliper DS 370 FEA		
	with thruster 455	with thruster 456	with thruster 457
Brake disc diameter	Braking torque	Braking torque	Braking torque
mm	Nm	Nm	Nm
500	2950	5000	7400
560	3450	5800	8600
630	4000	6750	10000
710	4550	7850	11600
800	5350	9050	13400
900	6200	10400	15400
1000	7000	11750	17400
1250	9000	15000	22400
Clamping force	20100 N	33850 N	50000 N
Braking torque adjustable	20 - 100%	20 - 100%	20 - 100%
Nominal power	370 W	590 W	680 W
Oil volume	4,5 l	11 l	11 l
Voltage	230/400 V	230/400 V	230/400 V
Weight	241 kg	267 kg	267 kg

The braking torques shown in the table are based on a theoretical friction coefficient of 0,4.

Brake Caliper DS 370 FEA

spring activated – electrohydraulically released

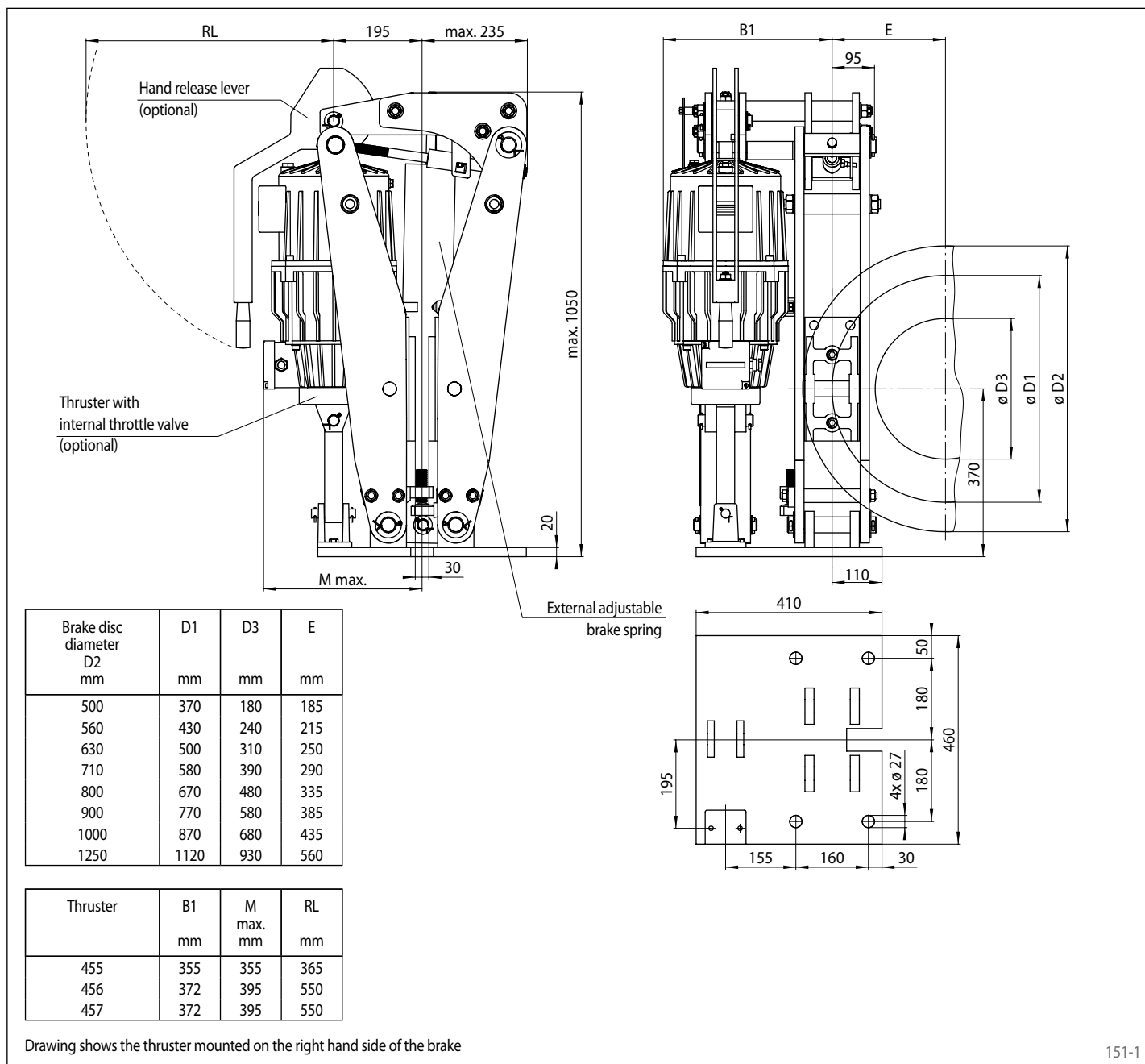

Options

- Micro-switch wear control
- Micro-switch status control
- Micro-switch residual piston stroke warning
- Hand release lever
- Hand release lever with padlock
- Thruster with internal throttle valve
- Thruster in heat resistant design
- Corrosion protected design
- Friction lining of sintered metal
- Pneumatic cylinder instead of thruster
- Thruster also available in other voltages and frequencies

Brake Caliper DT 200 FEM ... NC

spring activated – electrohydraulically released
 Drum Brake according to DIN 15 435



Features	Code
Brake Caliper	D
Drum Brake	T
Frame size 200	200
Spring activated	F
Electrohydraulically released	E
Manual adjustment to accommodate friction block wear	M
Thrusters 451 or 452 are available	451 452
Material: cast	NC

Example for ordering

Brake Caliper DT 200 FEM, thruster 452, material: cast

DT 200 FEM - 452 - NC

Technical Data

	Brake Caliper DT 200 FEM ... NC	
	with thruster 451	with thruster 452
Brake drum diameter	Braking torque	Braking torque
mm	Nm	Nm
200	230	310
Clamping force	2875 N	3875 N
Braking torque adjustable (optional)	20 - 100%	20 - 100%
Nominal power	130 W	180 W
Oil volume	1,4 l	2,5 l
Voltage	230/400 V	230/400 V
Weight	26 kg	31 kg

The braking torques shown in the table are based on a theoretical friction coefficient of 0,4.

Brake Caliper DT 200 FEM ... NC

spring activated – electrohydraulically released
 Drum Brake according to DIN 15 435

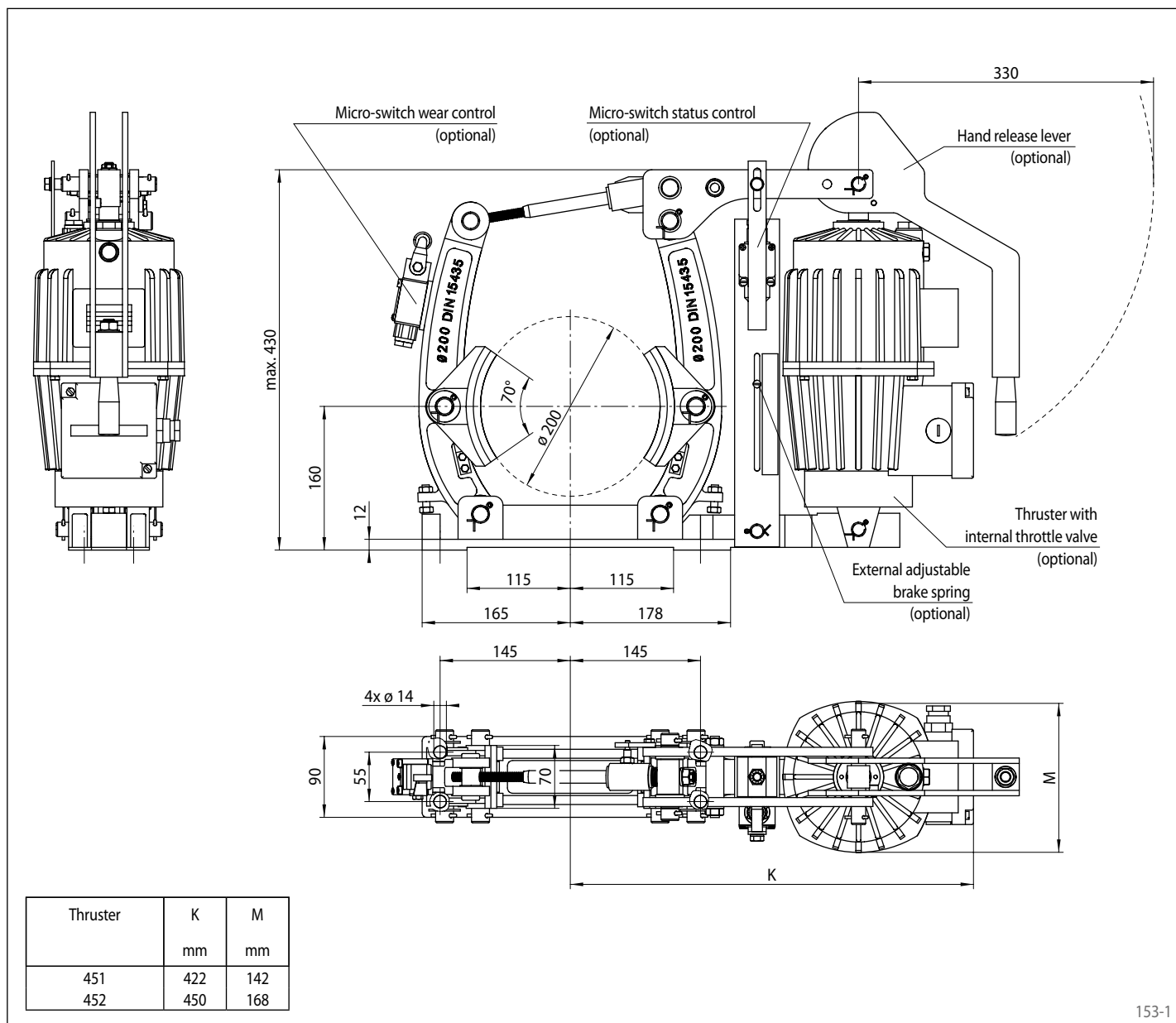

153-1

Options

- External adjustable brake spring
- Micro-switch wear control
- Micro-switch status control
- Hand release lever
- Thruster with internal throttle valve
- Thruster in heat resistant design
- Corrosion protected design
- Wider brake shoes and brake drums

Brake Caliper DT 200 FEA ... NC

spring activated – electrohydraulically released
 Drum Brake according to DIN 15 435



Figure shows product with full equipment

154-1

Features	Code
Brake Caliper	D
Drum Brake	T
Frame size 200	200
Spring activated	F
Electrohydraulically released	E
Automatic adjustment to accommodate friction block wear	A
Thrusters 451 or 452 are available	451 452
Material: cast	NC

Example for ordering

Brake Caliper DT 200 FEA, thruster 452, material: cast

DT 200 FEA - 452 - NC

Technical Data

	Brake Caliper DT 200 FEA ... NC	
	with thruster 451	with thruster 452
Brake drum diameter	Braking torque	Braking torque
mm	Nm	Nm
200	230	310
Clamping force	2875 N	3875 N
Braking torque adjustable (optional)	20 - 100%	20 - 100%
Nominal power	130 W	180 W
Oil volume	1,4 l	2,5 l
Voltage	230/400 V	230/400 V
Weight	26 kg	31 kg

The braking torques shown in the table are based on a theoretical friction coefficient of 0,4.

Brake Caliper DT 200 FEA ... NC

spring activated – electrohydraulically released
 Drum Brake according to DIN 15 435

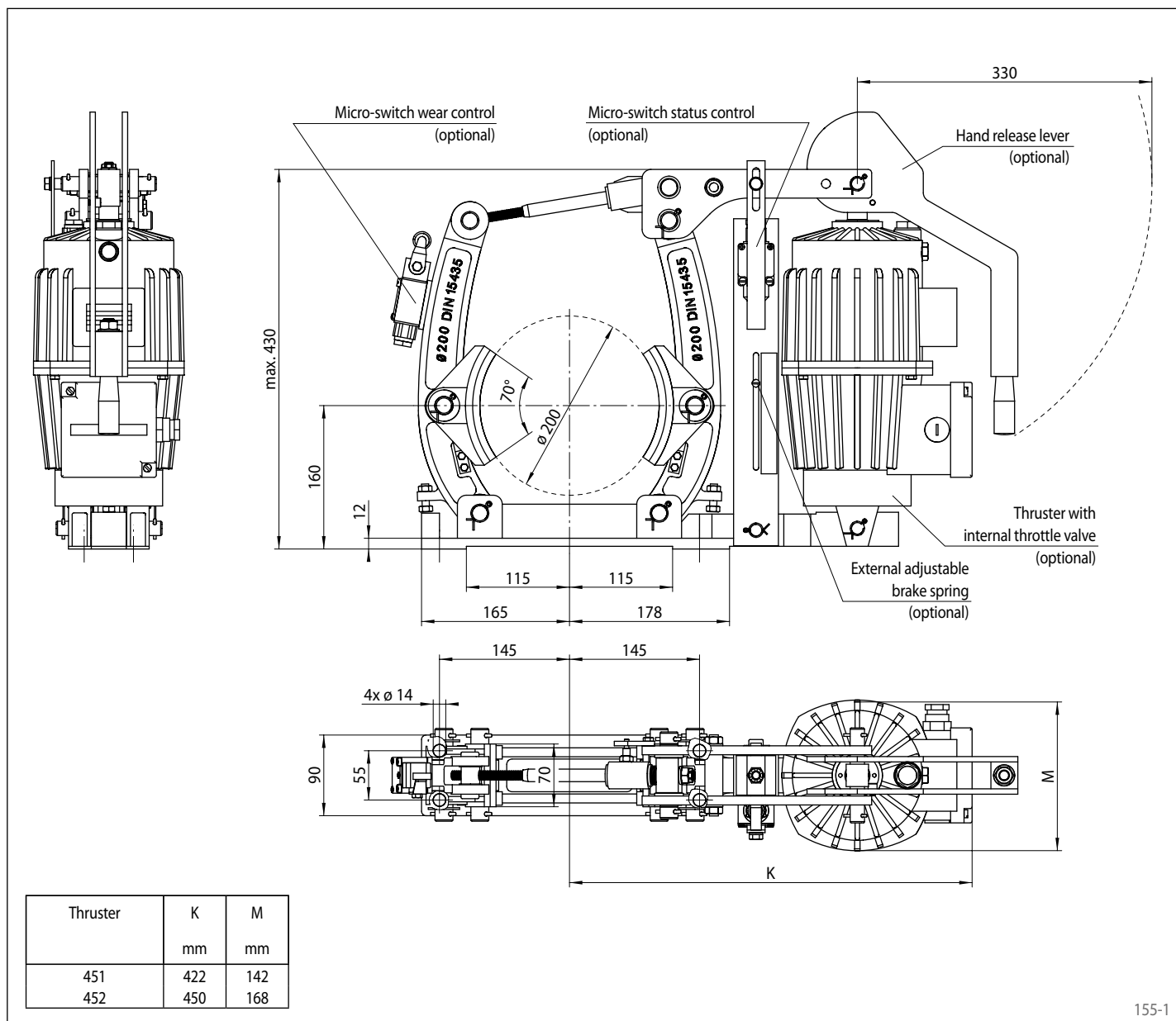

155-1

Options

- External adjustable brake spring
- Micro-switch wear control
- Micro-switch status control
- Hand release lever
- Thruster with internal throttle valve
- Thruster in heat resistant design
- Corrosion protected design
- Wider brake shoes and brake drums

Brake Caliper DT 200 FEA ... ST

spring activated – electrohydraulically released
 Drum Brake according to DIN 15 435



Figure shows product with full equipment

156-1

Features	Code
Brake Caliper	D
Drum Brake	T
Frame size 200	200
Spring activated	F
Electrohydraulically released	E
Automatic adjustment to accommodate friction block wear	A
Thrusters 451 or 452 are available	451 452
Material: steel	ST

Example for ordering

Brake Caliper DT 200 FEA, thruster 452, material: steel

DT 200 FEA - 452 - ST

Technical Data

	Brake Caliper DT 200 FEA ... ST	
	with thruster 451	with thruster 452
Brake drum diameter	Braking torque	Braking torque
mm	Nm	Nm
200	250	330
Clamping force	3 125 N	4 125 N
Braking torque adjustable (optional)	20 - 100%	20 - 100%
Nominal power	130 W	180 W
Oil volume	1,4 l	2,5 l
Voltage	230/400 V	230/400 V
Weight	32 kg	37 kg

The braking torques shown in the table are based on a theoretical friction coefficient of 0,4.

Brake Caliper DT 200 FEA ... ST

spring activated – electrohydraulically released
 Drum Brake according to DIN 15 435

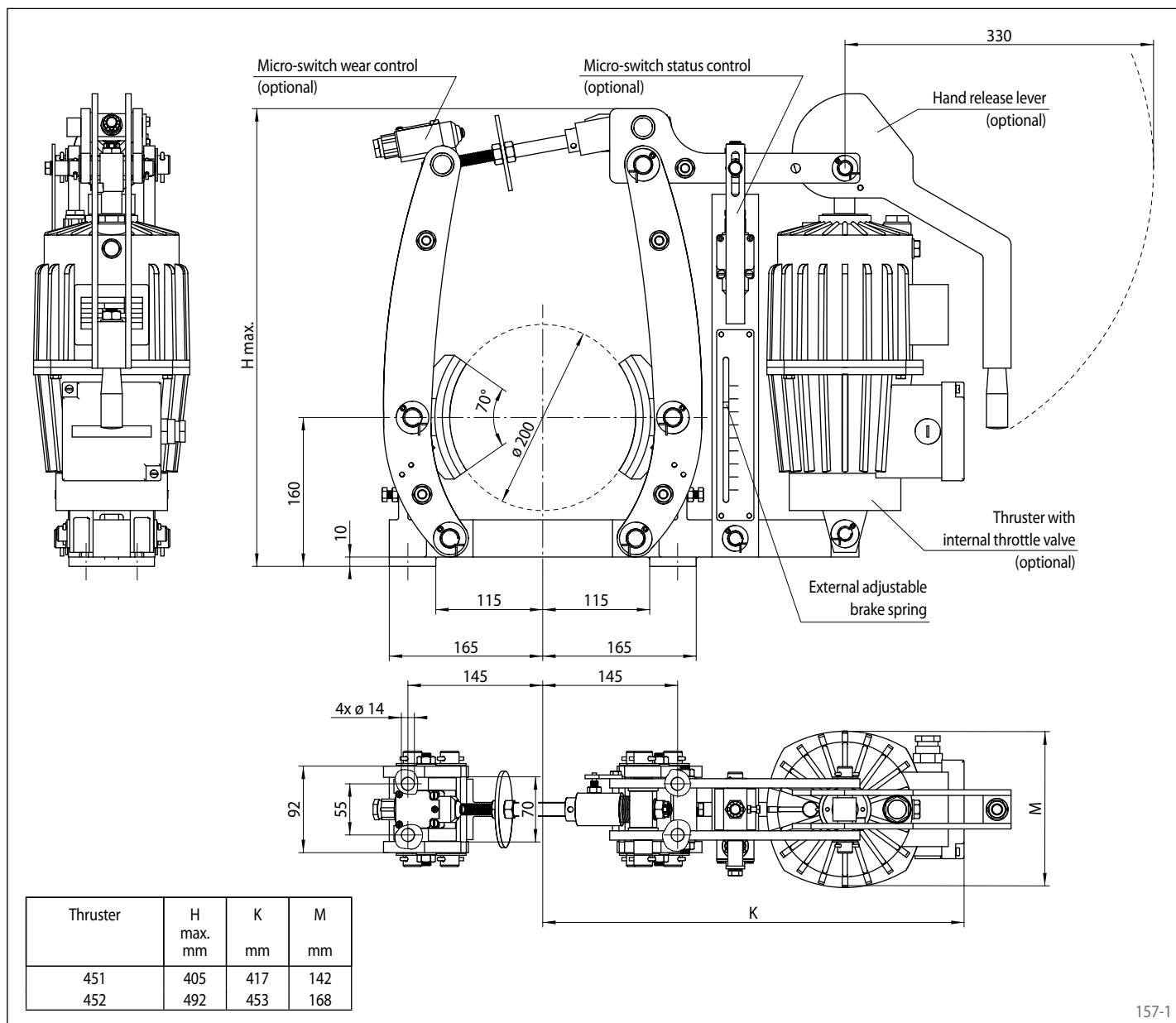

157-1

Options

- Micro-switch wear control
- Micro-switch status control
- Hand release lever
- Thruster with internal throttle valve
- Thruster in heat resistant design
- Corrosion protected design
- Wider brake shoes and brake drums

Brake Caliper DT 250 FEM ... NC

spring activated – electrohydraulically released
Drum Brake according to DIN 15 435



Features	Code
Brake Caliper	D
Drum Brake	T
Frame size 250	250
Spring activated	F
Electrohydraulically released	E
Manual adjustment to accommodate friction block wear	M
Thrusters 451, 452 or 453 are available	451 452 453
Material: cast	NC

Example for ordering

Brake Caliper DT 250 FEM, thruster 452, material: cast

DT 250 FEM - 452 - NC

Technical Data

	Brake Caliper DT 250 FEM ... NC		
	with thruster 451	with thruster 452	with thruster 453
Brake drum diameter	Braking torque	Braking torque	Braking torque
mm	Nm	Nm	Nm
250	260	350	700
Clamping force	2600 N	3500 N	7000 N
Braking torque adjustable (optional)	20 - 100%	20 - 100%	20 - 100%
Nominal power	130 W	180 W	240 W
Oil volume	1,4 l	2,5 l	3,5 l
Voltage	230/400 V	230/400 V	230/400 V
Weight	39 kg	44 kg	46 kg

The braking torques shown in the table are based on a theoretical friction coefficient of 0,4.

Brake Caliper DT 250 FEM ... NC

spring activated – electrohydraulically released
 Drum Brake according to DIN 15 435

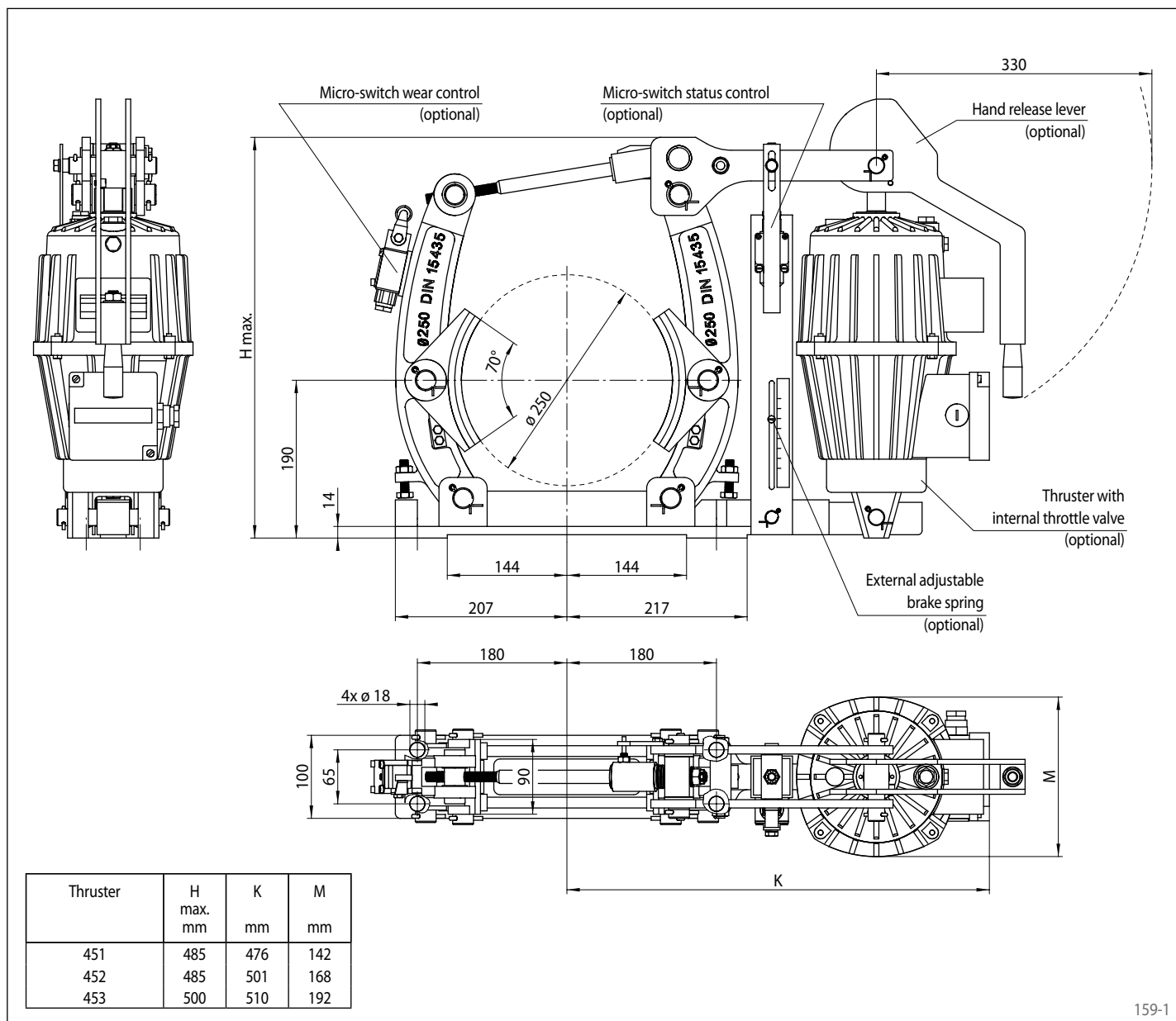

159-1

Options

- External adjustable brake spring
- Micro-switch wear control
- Micro-switch status control
- Hand release lever
- Thruster with internal throttle valve
- Thruster in heat resistant design
- Corrosion protected design
- Wider brake shoes and brake drums

Brake Caliper DT 250 FEA ... NC

spring activated – electrohydraulically released
 Drum Brake according to DIN 15 435



Features	Code
Brake Caliper	D
Drum Brake	T
Frame size 250	250
Spring activated	F
Electrohydraulically released	E
Automatic adjustment to accommodate friction block wear	A
Thrusters 451, 452 or 453 are available	451 452 453
Material: cast	NC

Example for ordering

Brake Caliper DT 250 FEA, thruster 452, material: cast

DT 250 FEA - 452 - NC

Technical Data

	Brake Caliper DT 250 FEA ... NC		
	with thruster 451	with thruster 452	with thruster 453
Brake drum diameter	Braking torque	Braking torque	Braking torque
mm	Nm	Nm	Nm
250	260	350	700
Clamping force	2600 N	3500 N	7000 N
Braking torque adjustable (optional)	20 - 100%	20 - 100%	20 - 100%
Nominal power	130 W	180 W	240 W
Oil volume	1,4 l	2,5 l	3,5 l
Voltage	230/400 V	230/400 V	230/400 V
Weight	39 kg	44 kg	46 kg

The braking torques shown in the table are based on a theoretical friction coefficient of 0,4.

Brake Caliper DT 250 FEA ... NC

spring activated – electrohydraulically released
 Drum Brake according to DIN 15 435

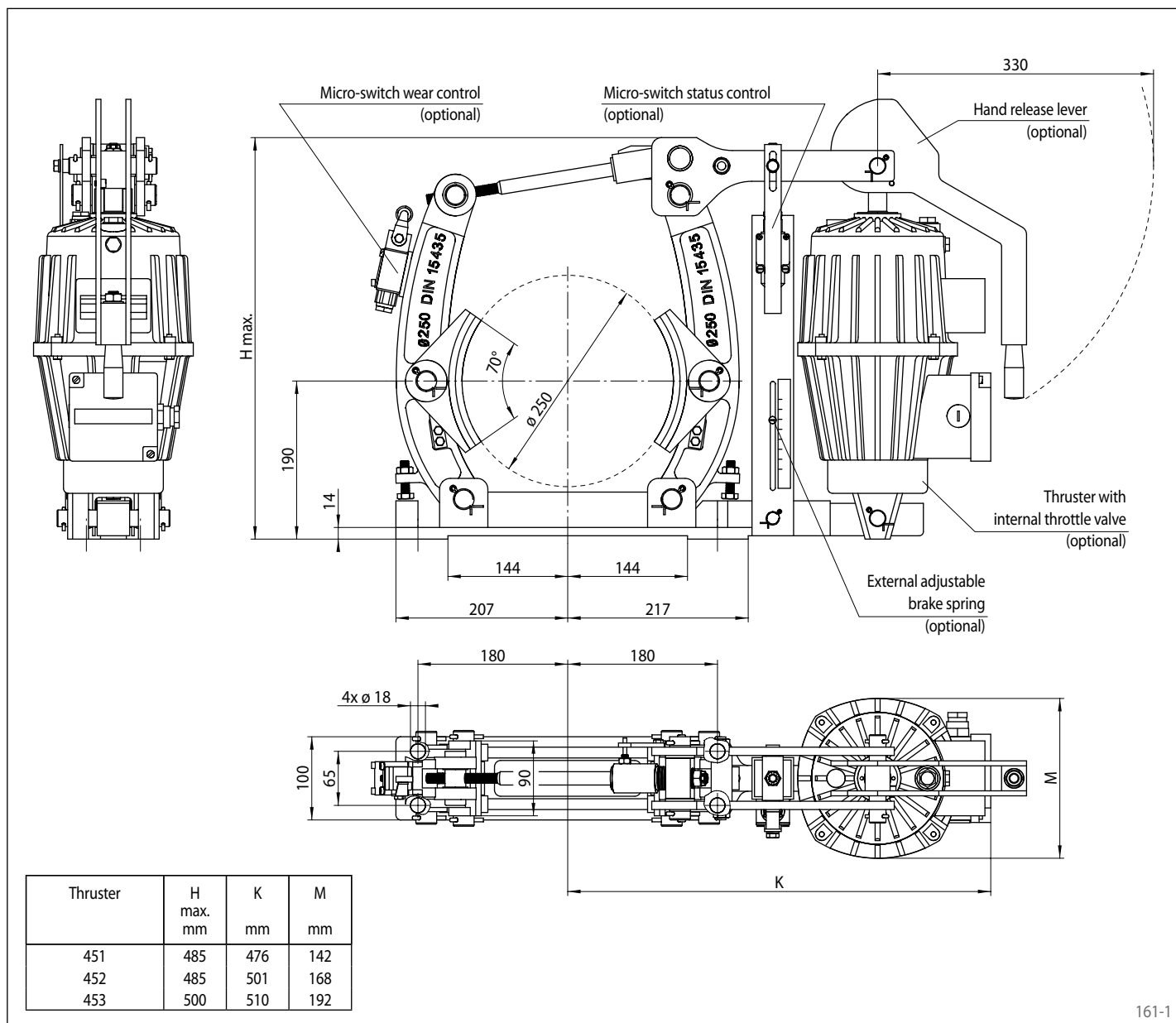

161-1

Options

- External adjustable brake spring
- Micro-switch wear control
- Micro-switch status control
- Hand release lever
- Thruster with internal throttle valve
- Thruster in heat resistant design
- Corrosion protected design
- Wider brake shoes and brake drums

Brake Caliper DT 250 FEA ... ST

spring activated – electrohydraulically released
 Drum Brake according to DIN 15 435



Features	Code
Brake Caliper	D
Drum Brake	T
Frame size 250	250
Spring activated	F
Electrohydraulically released	E
Automatic adjustment to accommodate friction block wear	A
Thrusters 451, 452 or 453 are available	451 452 453
Material: steel	ST

Example for ordering

Brake Caliper DT 250 FEA, thruster 452, material: steel

DT 250 FEA - 452 - ST

Technical Data

	Brake Caliper DT 250 FEA ... ST		
	with thruster 451	with thruster 452	with thruster 453
Brake drum diameter	Braking torque	Braking torque	Braking torque
mm	Nm	Nm	Nm
250	300	400	750
Clamping force	3000 N	4000 N	7500 N
Braking torque adjustable (optional)	20 - 100%	20 - 100%	20 - 100%
Nominal power	130 W	180 W	240 W
Oil volume	1,4 l	2,5 l	3,5 l
Voltage	230/400 V	230/400 V	230/400 V
Weight	40 kg	45 kg	47 kg

The braking torques shown in the table are based on a theoretical friction coefficient of 0,4.

Brake Caliper DT 250 FEA ... ST

spring activated – electrohydraulically released
Drum Brake according to DIN 15 435

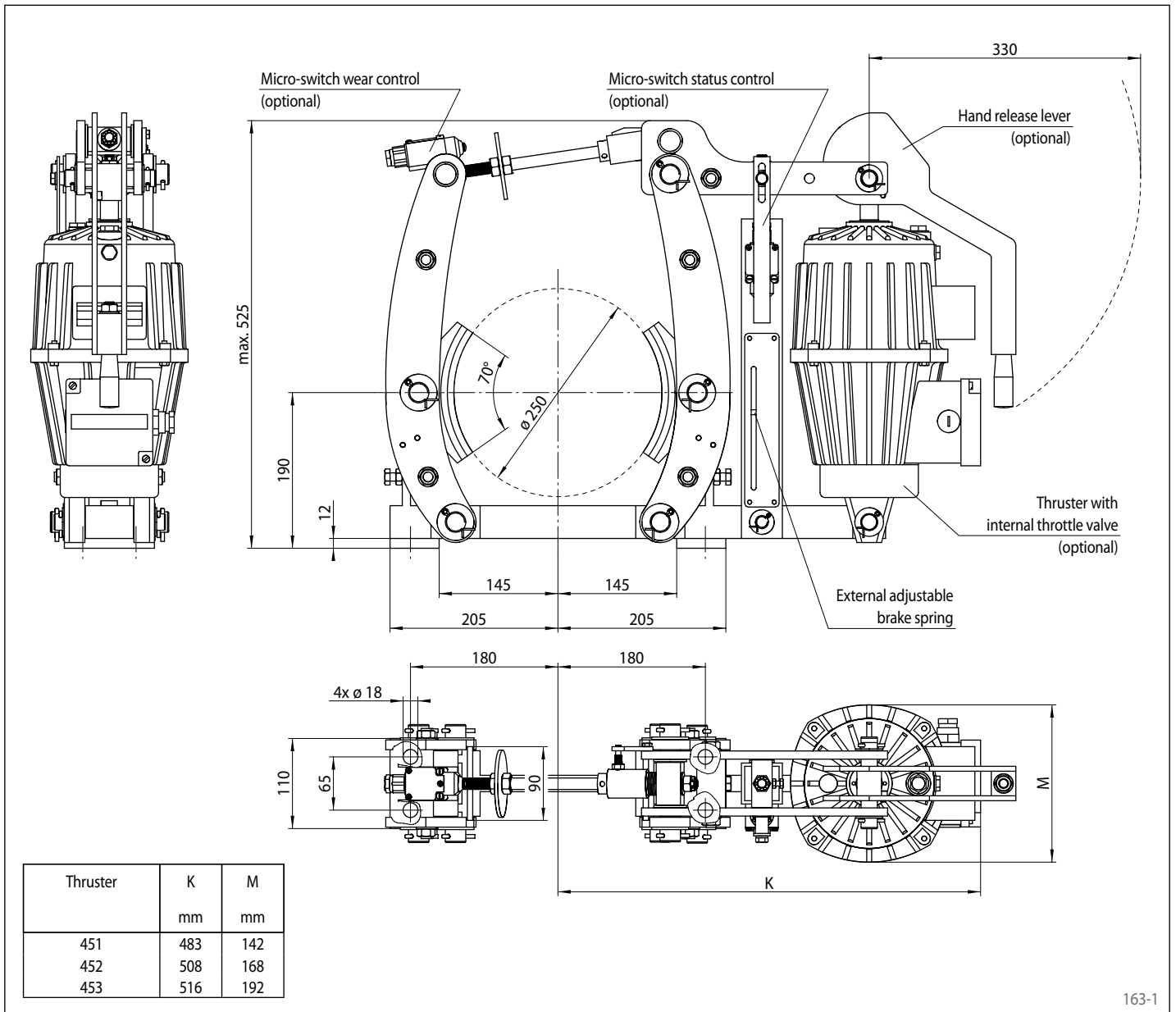

163-1

Options

- Micro-switch wear control
- Micro-switch status control
- Hand release lever
- Thruster with internal throttle valve
- Thruster in heat resistant design
- Corrosion protected design
- Wider brake shoes and brake drums

Brake Caliper DT 315 FEM ... NC

spring activated – electrohydraulically released
 Drum Brake according to DIN 15 435



Features	Code
Brake Caliper	D
Drum Brake	T
Frame size 315	315
Spring activated	F
Electrohydraulically released	E
Manual adjustment to accommodate friction block wear	M
Thrusters 451, 452, 453, 454 or 455 are available	451 to 455
Material: cast	NC

Example for ordering

Brake Caliper DT 315 FEM, thruster 453, material: cast

DT 315 FEM - 453 - NC

Technical Data

	Brake Caliper DT 315 FEM ... NC				
	with thruster 451	with thruster 452	with thruster 453	with thruster 454	with thruster 455
Brake drum diameter	Braking torque	Braking torque	Braking torque	Braking torque	Braking torque
mm	Nm	Nm	Nm	Nm	Nm
315	285	425	850	1070	1700
Clamping force	2300 N	3400 N	6700 N	8500 N	13500 N
Braking torque adjustable (optional)	20 - 100%	20 - 100%	20 - 100%	20 - 100%	20 - 100%
Nominal power	130 W	180 W	240 W	280 W	370 W
Oil volume	1,4 l	2,5 l	3,5 l	3,5 l	4,5 l
Voltage	230/400 V	230/400 V	230/400 V	230/400 V	230/400 V
Weight	49 kg	54 kg	56 kg	56 kg	62 kg

The braking torques shown in the table are based on a theoretical friction coefficient of 0,4.

Brake Caliper DT 315 FEM ... NC

spring activated – electrohydraulically released
 Drum Brake according to DIN 15 435

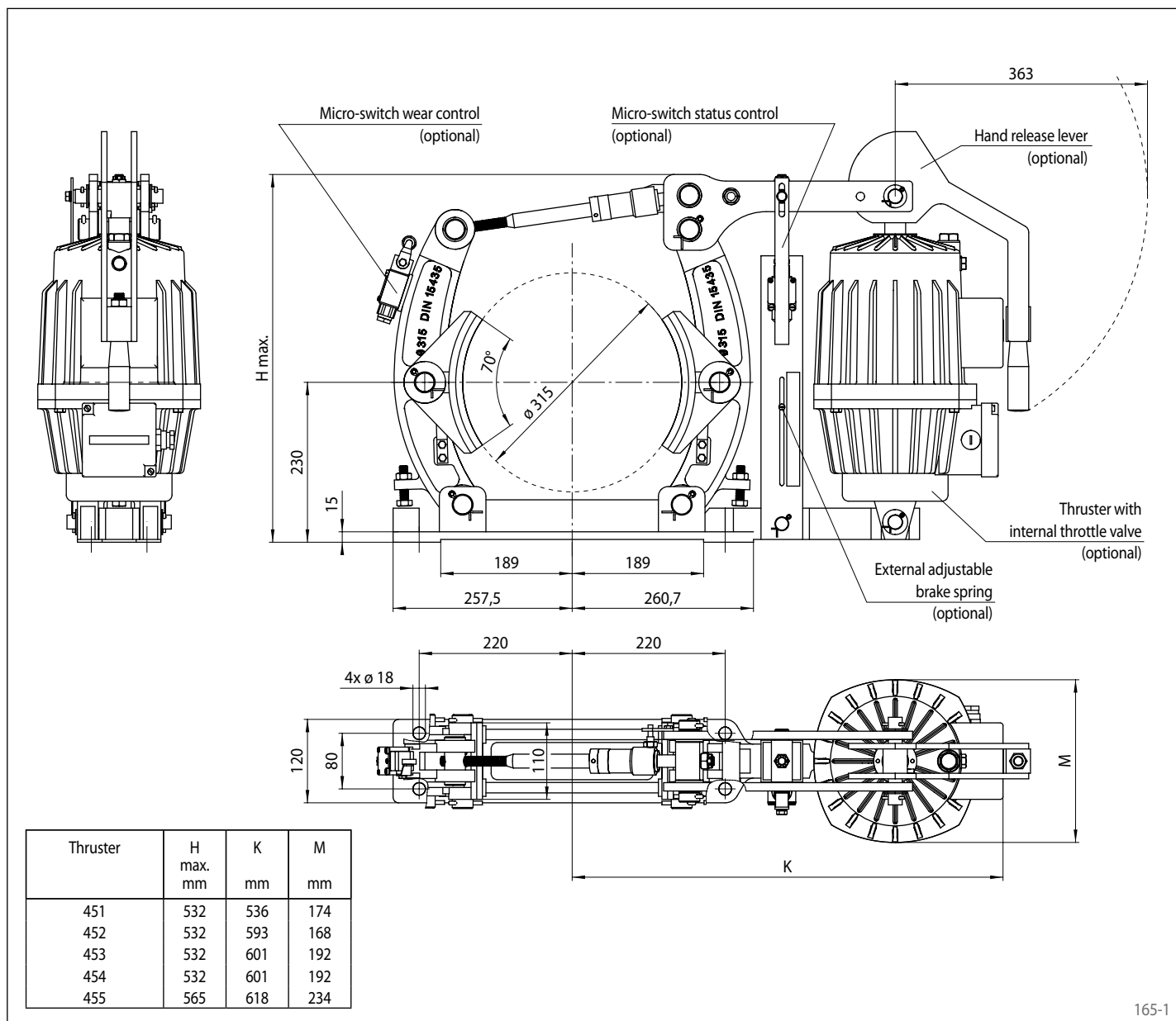

165-1

Options

- External adjustable brake spring
- Micro-switch wear control
- Micro-switch status control
- Hand release lever
- Thruster with internal throttle valve
- Thruster in heat resistant design
- Corrosion protected design
- Wider brake shoes and brake drums

Brake Caliper DT 315 FEA ... NC

spring activated – electrohydraulically released
Drum Brake according to DIN 15 435



Features	Code
Brake Caliper	D
Drum Brake	T
Frame size 315	315
Spring activated	F
Electrohydraulically released	E
Automatic adjustment to accommodate friction block wear	A
Thrusters 451, 452, 453, 454 or 455 are available	451 to 455
Material: cast	NC

Example for ordering

Brake Caliper DT 315 FEA, thruster 453, material: cast

DT 315 FEA - 453 - NC

Technical Data

	Brake Caliper DT 315 FEA ... NC				
	with thruster 451	with thruster 452	with thruster 453	with thruster 454	with thruster 455
Brake drum diameter	Braking torque	Braking torque	Braking torque	Braking torque	Braking torque
mm	Nm	Nm	Nm	Nm	Nm
315	285	425	850	1070	1700
Clamping force	2300 N	3400 N	6700 N	8500 N	13500 N
Braking torque adjustable (optional)	20 - 100%	20 - 100%	20 - 100%	20 - 100%	20 - 100%
Nominal power	130 W	180 W	240 W	280 W	370 W
Oil volume	1,4 l	2,5 l	3,5 l	3,5 l	4,5 l
Voltage	230/400 V	230/400 V	230/400 V	230/400 V	230/400 V
Weight	49 kg	54 kg	56 kg	56 kg	62 kg

The braking torques shown in the table are based on a theoretical friction coefficient of 0,4.

Brake Caliper DT 315 FEA ... NC

spring activated – electrohydraulically released
Drum Brake according to DIN 15 435

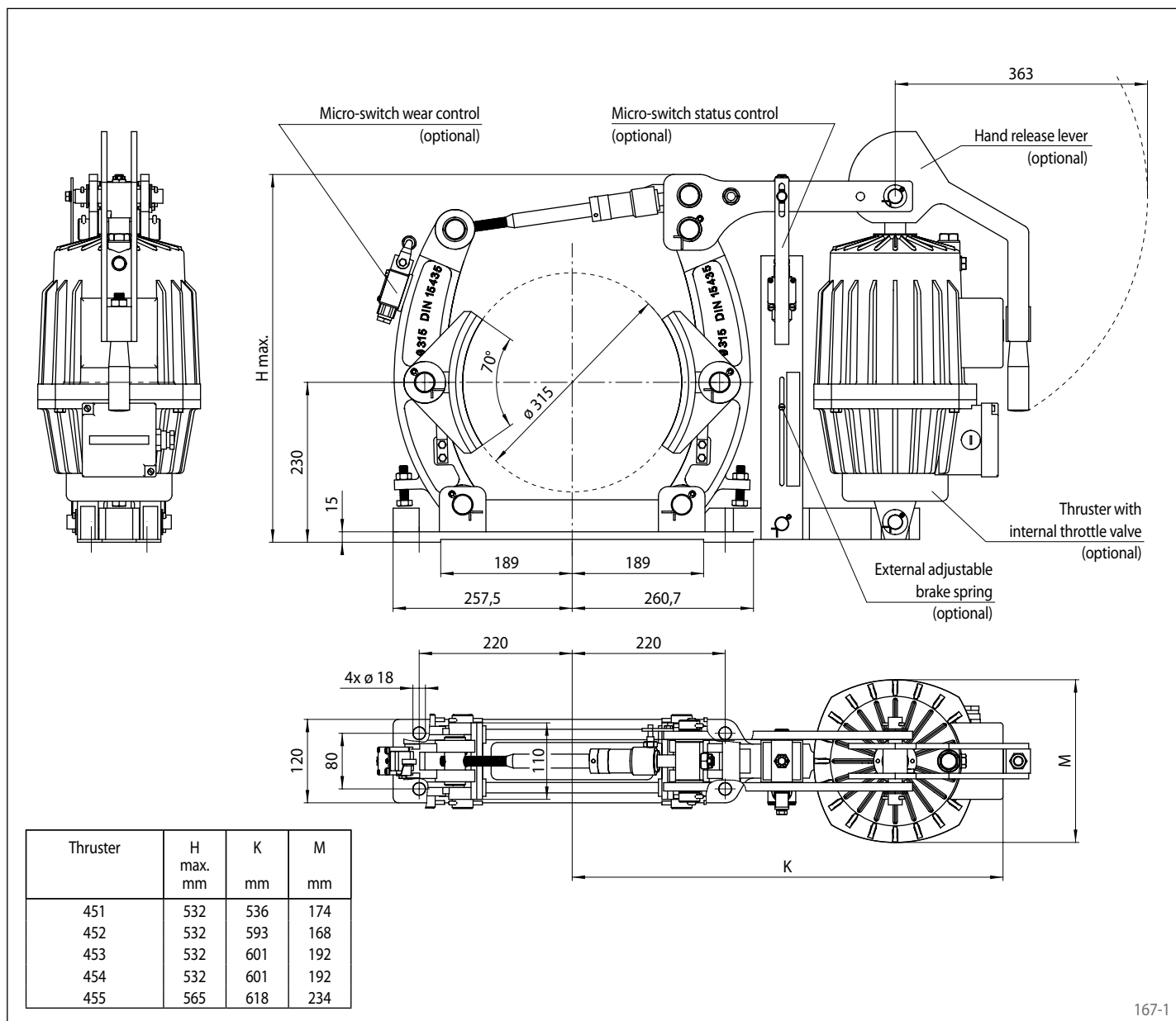

167-1

Options

- External adjustable brake spring
- Micro-switch wear control
- Micro-switch status control
- Hand release lever
- Thruster with internal throttle valve
- Thruster in heat resistant design
- Corrosion protected design
- Wider brake shoes and brake drums

Brake Caliper DT 315 FEA ... ST

spring activated – electrohydraulically released
 Drum Brake according to DIN 15 435

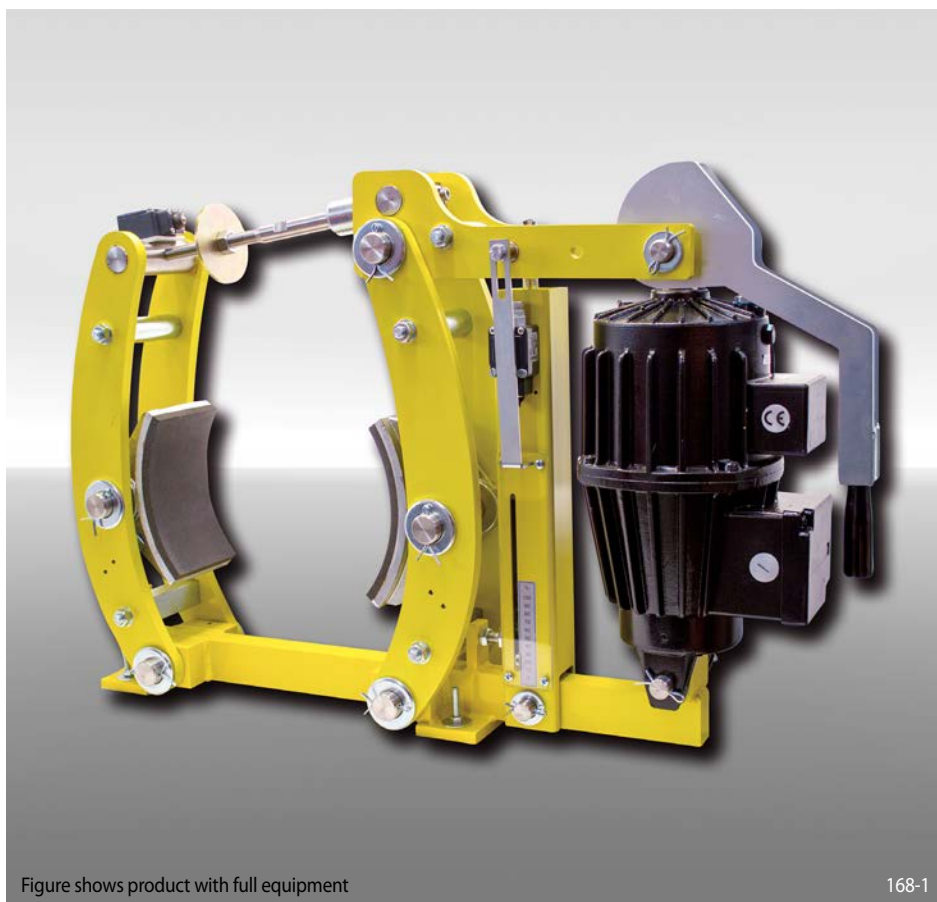

Figure shows product with full equipment

168-1

Features	Code
Brake Caliper	D
Drum Brake	T
Frame size 315	315
Spring activated	F
Electrohydraulically released	E
Automatic adjustment to accommodate friction block wear	A
Thrusters 451, 452, 453 or 455 are available	451 to 455
Material: steel	ST

Example for ordering

Brake Caliper DT 315 FEA, thruster 453, material: steel

DT 315 FEA - 453 - ST

Technical Data

	Brake Caliper DT 315 FEA ... ST			
	with thruster 451	with thruster 452	with thruster 453	with thruster 455
Brake drum diameter	Braking torque	Braking torque	Braking torque	Braking torque
mm	Nm	Nm	Nm	Nm
315	350	480	950	1800
Clamping force	2800 N	3800 N	7500 N	14300 N
Braking torque adjustable (optional)	20 - 100%	20 - 100%	20 - 100%	20 - 100%
Nominal power	130 W	180 W	240 W	370 W
Oil volume	1,4 l	2,5 l	3,5 l	4,5 l
Voltage	230/400 V	230/400 V	230/400 V	230/400 V
Weight	56 kg	61 kg	63 kg	69 kg

The braking torques shown in the table are based on a theoretical friction coefficient of 0,4.

Brake Caliper DT 315 FEA ... ST

spring activated – electrohydraulically released
 Drum Brake according to DIN 15 435

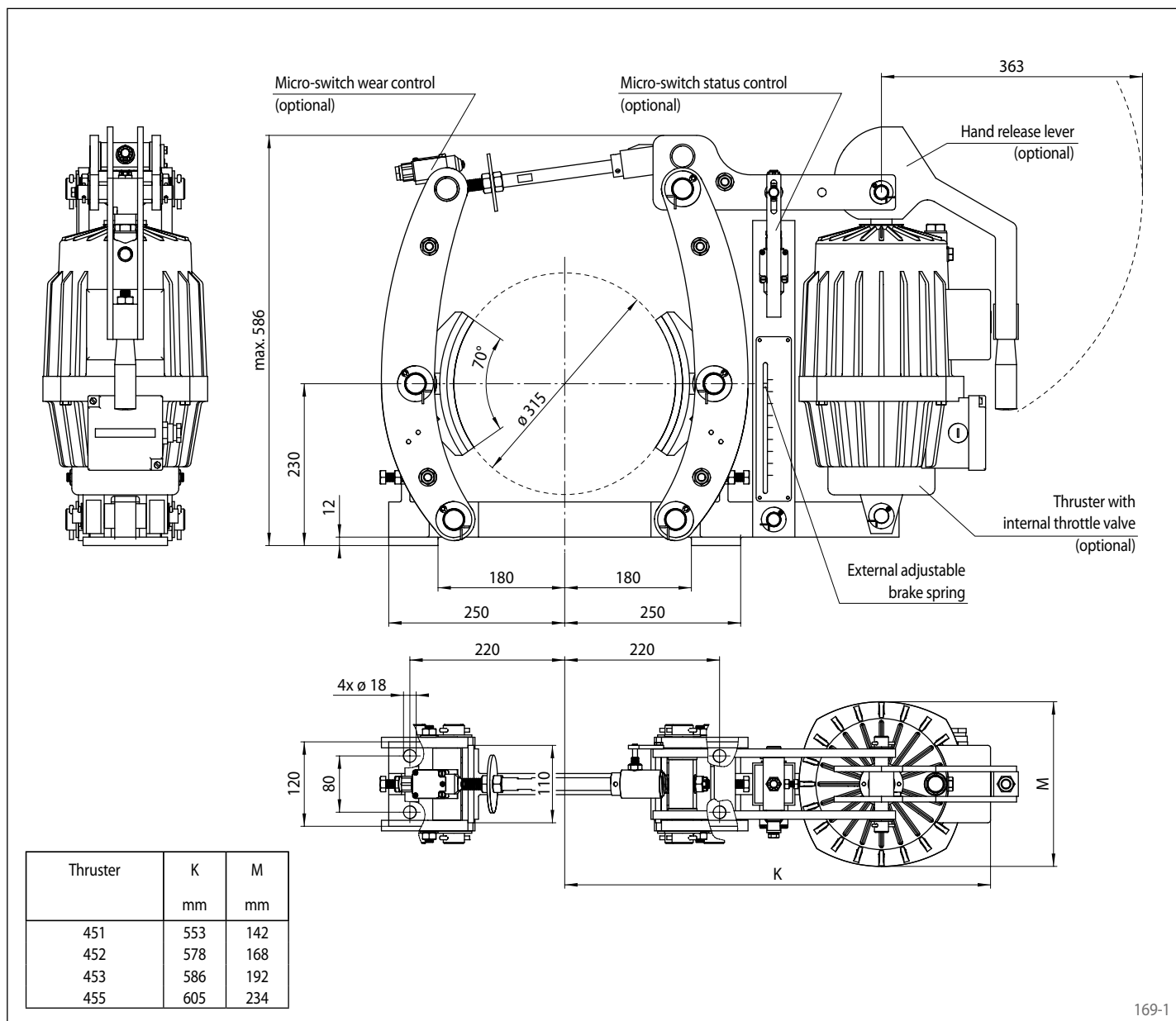

169-1

Options

- Micro-switch wear control
- Micro-switch status control
- Hand release lever
- Thruster with internal throttle valve
- Thruster in heat resistant design
- Corrosion protected design
- Wider brake shoes and brake drums

Brake Caliper DT 400 FEM ... NC

spring activated – electrohydraulically released
 Drum Brake according to DIN 15 435



Figure shows product with full equipment

170-1

Features	Code
Brake Caliper	D
Drum Brake	T
Frame size 400	400
Spring activated	F
Electrohydraulically released	E
Manual adjustment to accommodate friction block wear	M
Thrusters 452, 453, 454 or 455 are available	452 to 455
Material: cast	NC

Example for ordering

Brake Caliper DT 400 FEM, thruster 453, material: cast

DT 400 FEM - 453 - NC

Technical Data

	Brake Caliper DT 400 FEM ... NC			
	with thruster 452	with thruster 453	with thruster 454	with thruster 455
Brake drum diameter	Braking torque	Braking torque	Braking torque	Braking torque
mm	Nm	Nm	Nm	Nm
400	525	1040	1300	2075
Clamping force	3300 N	6500 N	8100 N	13000 N
Braking torque adjustable (optional)	20 - 100%	20 - 100%	20 - 100%	20 - 100%
Nominal power	180 W	240 W	280 W	370 W
Oil volume	2,5 l	3,5 l	3,5 l	4,5 l
Voltage	230/400 V	230/400 V	230/400 V	230/400 V
Weight	80 kg	82 kg	82 kg	88 kg

The braking torques shown in the table are based on a theoretical friction coefficient of 0,4.

Brake Caliper DT 400 FEM ... NC

spring activated – electrohydraulically released
 Drum Brake according to DIN 15 435

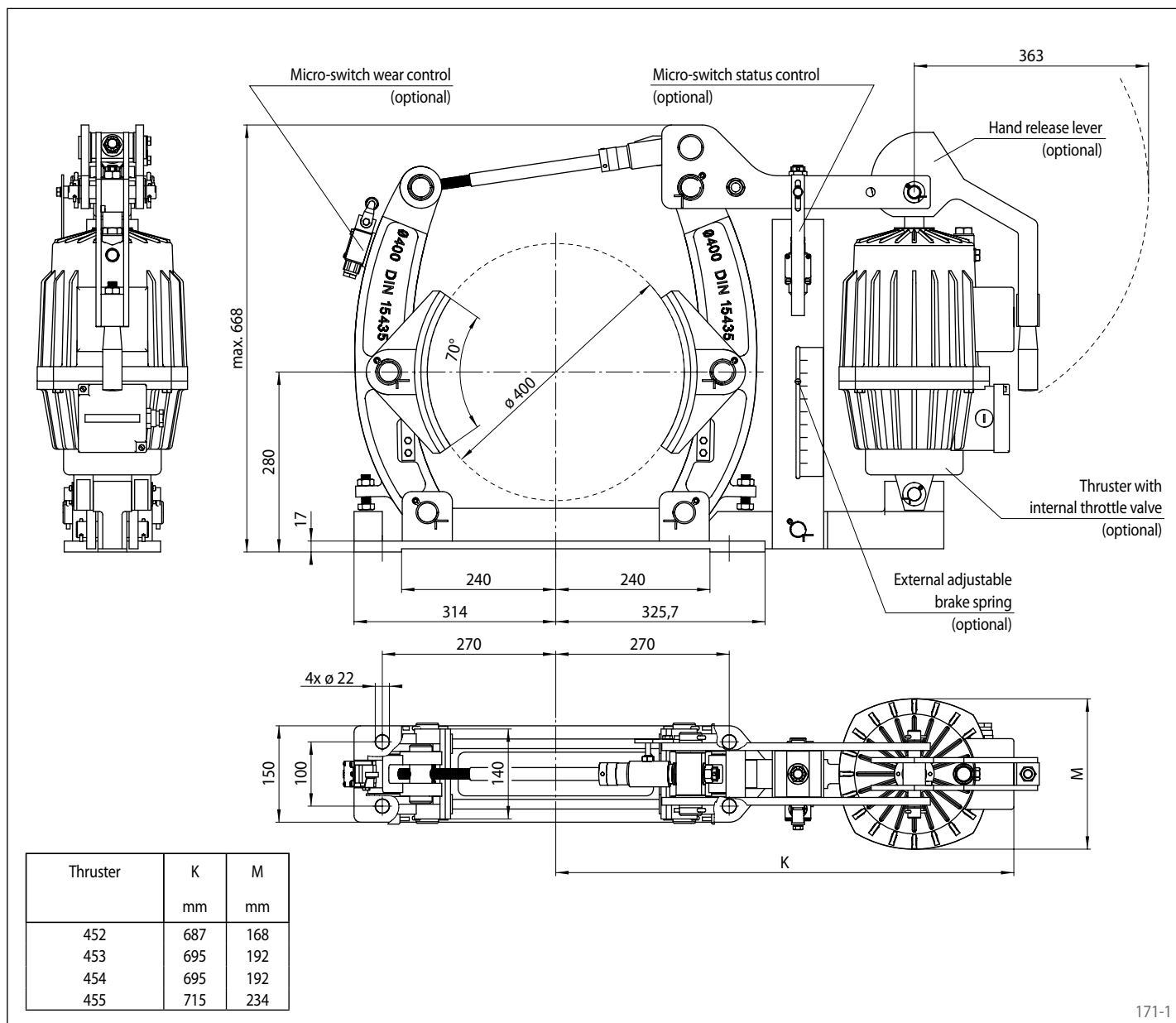

171-1

Options

- External adjustable brake spring
- Micro-switch wear control
- Micro-switch status control
- Hand release lever
- Thruster with internal throttle valve
- Thruster in heat resistant design
- Corrosion protected design
- Wider brake shoes and brake drums

Brake Caliper DT 400 FEA ... NC

spring activated – electrohydraulically released
 Drum Brake according to DIN 15 435



Figure shows product with full equipment

172-1

Features	Code
Brake Caliper	D
Drum Brake	T
Frame size 400	400
Spring activated	F
Electrohydraulically released	E
Automatic adjustment to accommodate friction block wear	A
Thrusters 452, 453, 454 or 455 are available	452 to 455
Material: cast	NC

Example for ordering

Brake Caliper DT 400 FEA, thruster 453, material: cast

DT 400 FEA - 453 - NC

Technical Data

	Brake Caliper DT 400 FEA ... NC			
	with thruster 452	with thruster 453	with thruster 454	with thruster 455
Brake drum diameter	Braking torque	Braking torque	Braking torque	Braking torque
mm	Nm	Nm	Nm	Nm
400	525	1040	1300	2075
Clamping force	3300 N	6500 N	8100 N	13000 N
Braking torque adjustable (optional)	20 - 100%	20 - 100%	20 - 100%	20 - 100%
Nominal power	180 W	240 W	280 W	370 W
Oil volume	2,5 l	3,5 l	3,5 l	4,5 l
Voltage	230/400 V	230/400 V	230/400 V	230/400 V
Weight	80 kg	82 kg	82 kg	88 kg

The braking torques shown in the table are based on a theoretical friction coefficient of 0,4.

Brake Caliper DT 400 FEA ... NC

spring activated – electrohydraulically released
 Drum Brake according to DIN 15 435

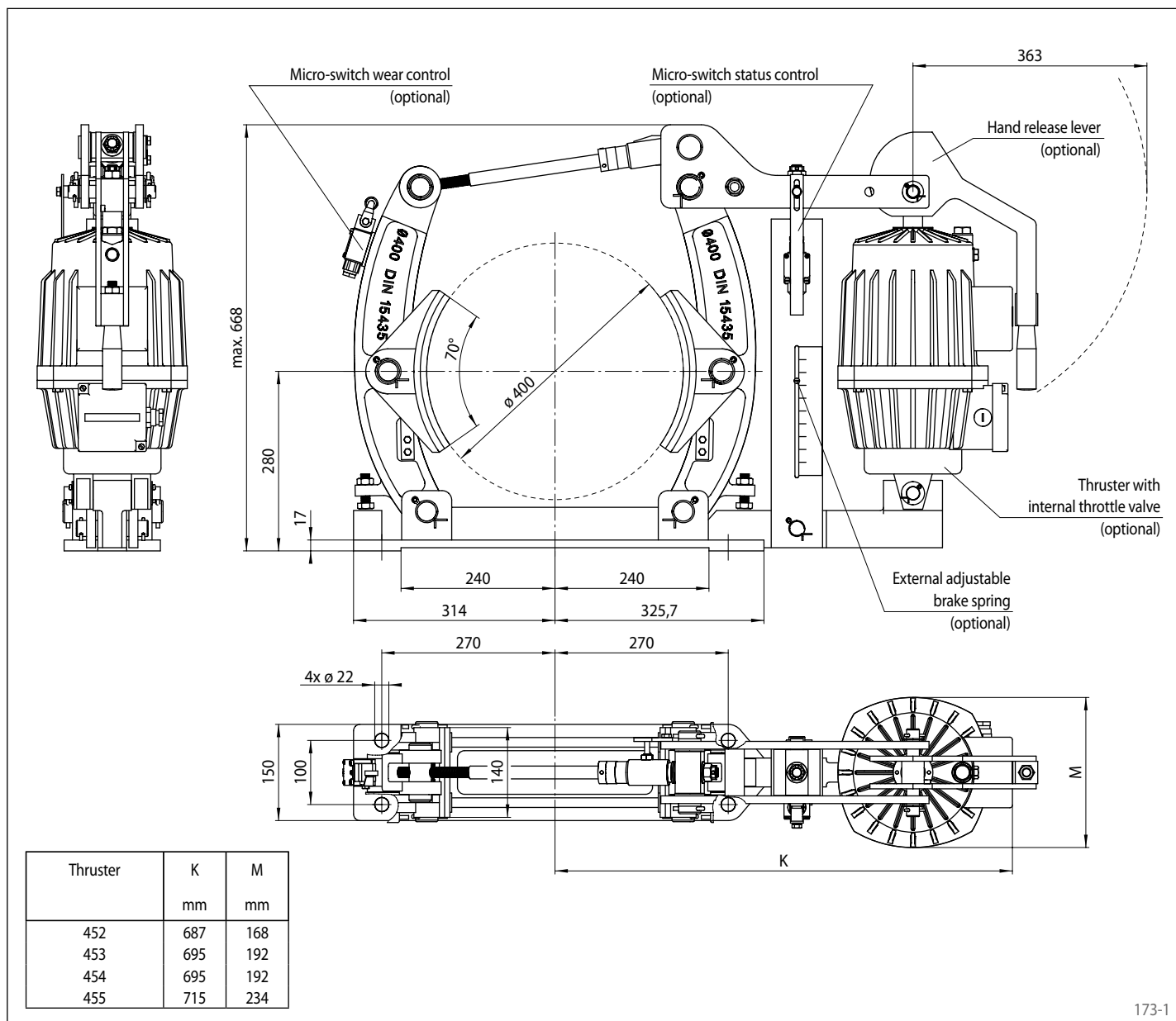

173-1

Options

- External adjustable brake spring
- Micro-switch wear control
- Micro-switch status control
- Hand release lever
- Thruster with internal throttle valve
- Thruster in heat resistant design
- Corrosion protected design
- Wider brake shoes and brake drums

Brake Caliper DT 400 FEA ... ST

spring activated – electrohydraulically released
 Drum Brake according to DIN 15 435



Features	Code
Brake Caliper	D
Drum Brake	T
Frame size 400	400
Spring activated	F
Electrohydraulically released	E
Automatic adjustment to accommodate friction block wear	A
Thrusters 452, 453 or 455 are available	452 453 455
Material: steel	ST

Example for ordering

Brake Caliper DT 400 FEA, thruster 453, material: steel

DT 400 FEA - 453 - ST

Technical Data

	Brake Caliper DT 400 FEA ... ST		
	with thruster 452	with thruster 453	with thruster 455
Brake drum diameter	Braking torque	Braking torque	Braking torque
mm	Nm	Nm	Nm
400	680	1300	2500
Clamping force	4200 N	8100 N	15600 N
Braking torque adjustable (optional)	20 - 100%	20 - 100%	20 - 100%
Nominal power	180 W	240 W	370 W
Oil volume	2,5 l	3,5 l	4,5 l
Voltage	230/400 V	230/400 V	230/400 V
Weight	98 kg	100 kg	106 kg

The braking torques shown in the table are based on a theoretical friction coefficient of 0,4.

Brake Caliper DT 400 FEA ... ST

spring activated – electrohydraulically released
 Drum Brake according to DIN 15 435

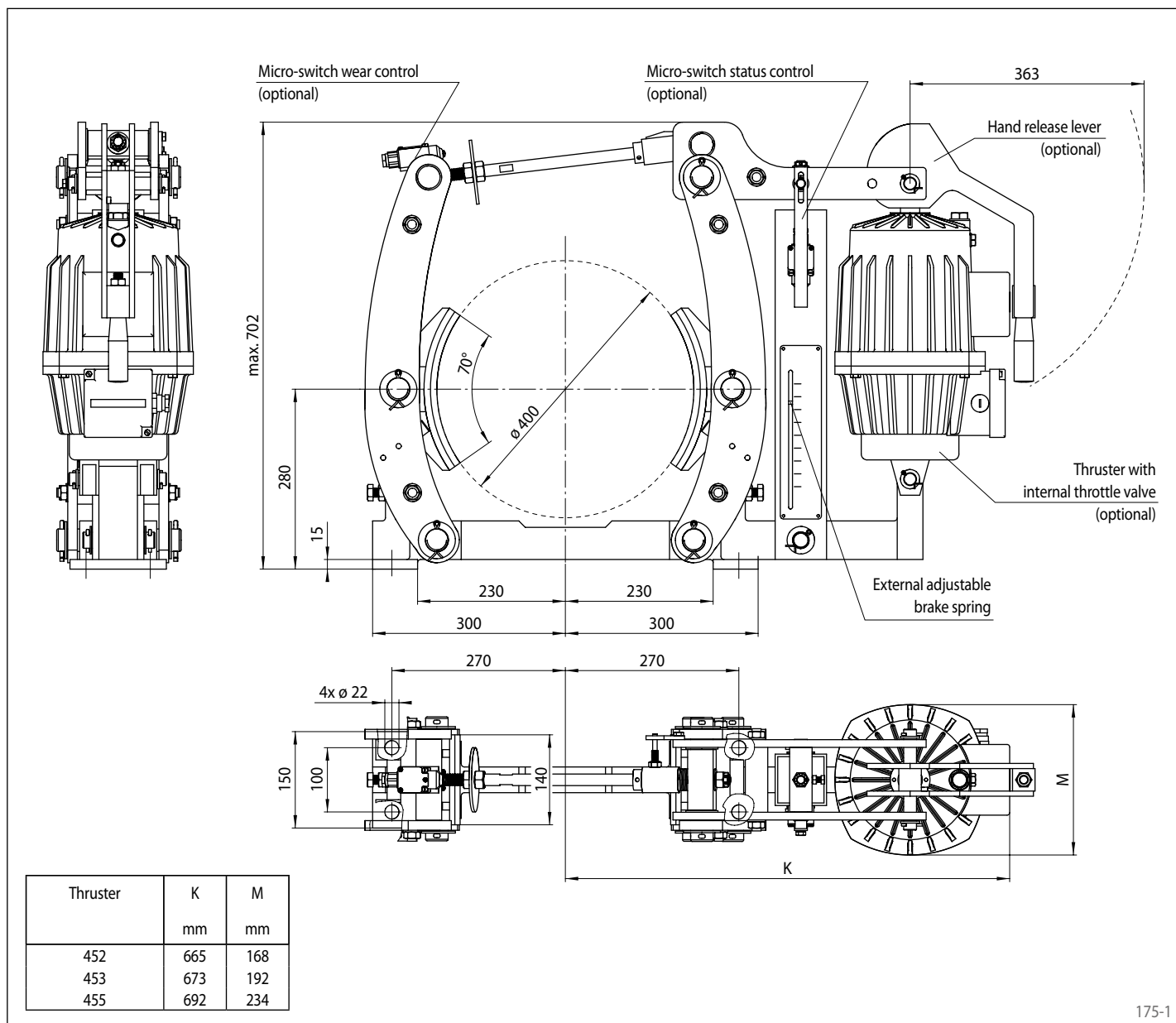

Options

- Micro-switch wear control
- Micro-switch status control
- Hand release lever
- Thruster with internal throttle valve
- Thruster in heat resistant design
- Corrosion protected design
- Wider brake shoes and brake drums

Brake Caliper DT 500 FEM ... NC

spring activated – electrohydraulically released
Drum Brake according to DIN 15 435



Figure shows product with full equipment

176-1

Features	Code
Brake Caliper	D
Drum Brake	T
Frame size 500	500
Spring activated	F
Electrohydraulically released	E
Manual adjustment to accommodate friction block wear	M
Thrusters 455 or 456 are available	455 456
Material: cast	NC

Example for ordering

Brake Caliper DT 500 FEM, thruster 456, material: cast

DT 500 FEM - 456 - NC

Technical Data

	Brake Caliper DT 500 FEM ... NC	
	with thruster 455	with thruster 456
Brake drum diameter	Braking torque	Braking torque
mm	Nm	Nm
500	2500	4170
Clamping force	12500 N	20800 N
Braking torque adjustable (optional)	20 - 100%	20 - 100%
Nominal power	370 W	590 W
Oil volume	4,5 l	11 l
Voltage	230/400 V	230/400 V
Weight	130 kg	156 kg

The braking torques shown in the table are based on a theoretical friction coefficient of 0,4.

Brake Caliper DT 500 FEM ... NC

spring activated – electrohydraulically released
 Drum Brake according to DIN 15 435

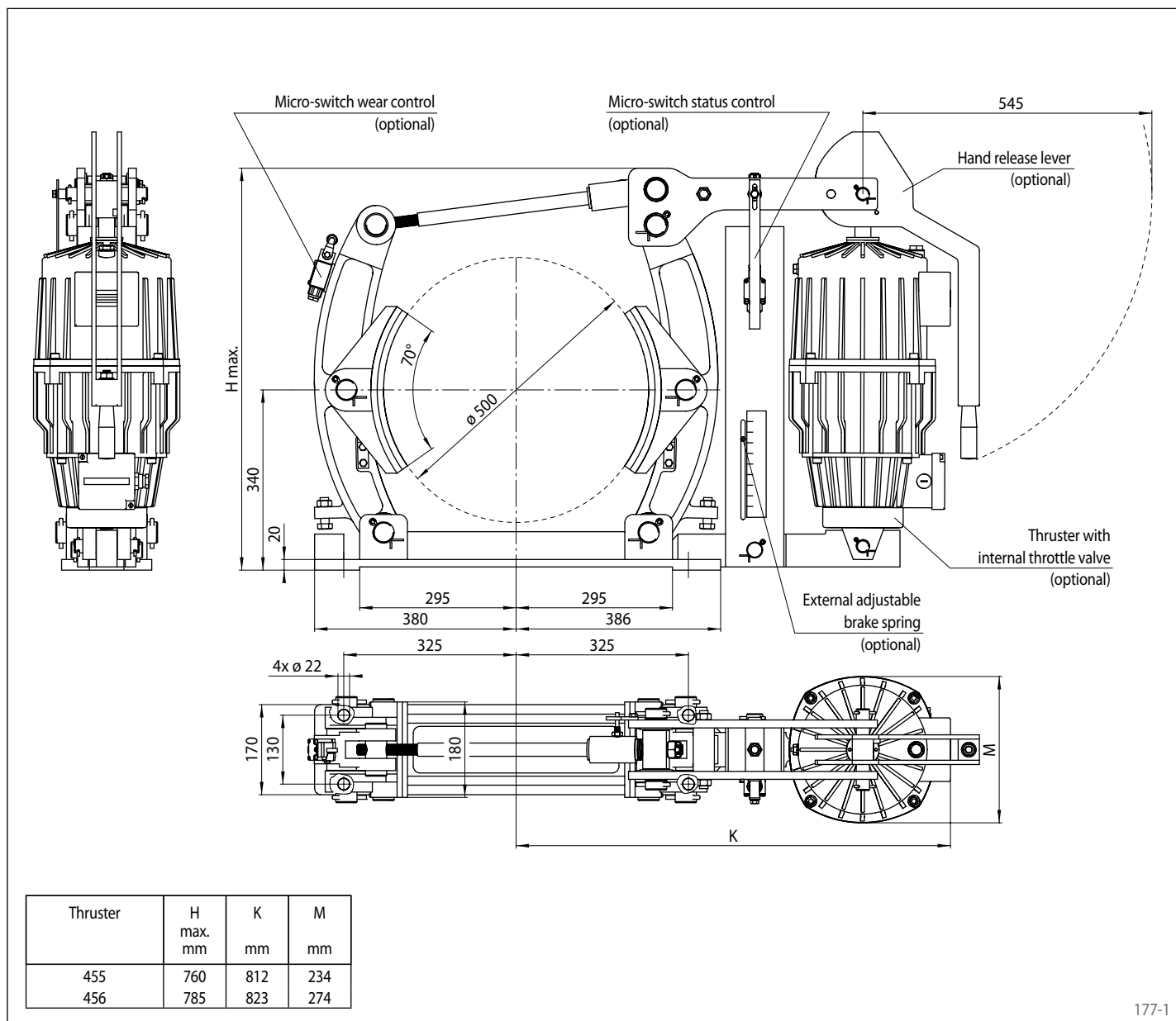

177-1

Options

- External adjustable brake spring
- Micro-switch wear control
- Micro-switch status control
- Hand release lever
- Thruster with internal throttle valve
- Thruster in heat resistant design
- Corrosion protected design
- Wider brake shoes and brake drums

Brake Caliper DT 500 FEA ... NC

spring activated – electrohydraulically released
 Drum Brake according to DIN 15 435



Figure shows product with full equipment

178-1

Features	Code
Brake Caliper	D
Drum Brake	T
Frame size 500	500
Spring activated	F
Electrohydraulically released	E
Automatic adjustment to accommodate friction block wear	A
Thrusters 455 or 456 are available	455 456
Material: cast	NC

Example for ordering

Brake Caliper DT 500 FEA, thruster 456, material: cast

DT 500 FEA - 456 - NC

Technical Data

	Brake Caliper DT 500 FEA ... NC	
	with thruster 455	with thruster 456
Brake drum diameter	Braking torque	Braking torque
mm	Nm	Nm
500	2500	4170
Clamping force	12500 N	20800 N
Braking torque adjustable (optional)	20 - 100%	20 - 100%
Nominal power	370 W	590 W
Oil volume	4,5 l	11 l
Voltage	230/400 V	230/400 V
Weight	130 kg	156 kg

The braking torques shown in the table are based on a theoretical friction coefficient of 0,4.

Brake Caliper DT 500 FEA ... NC

spring activated – electrohydraulically released
 Drum Brake according to DIN 15 435

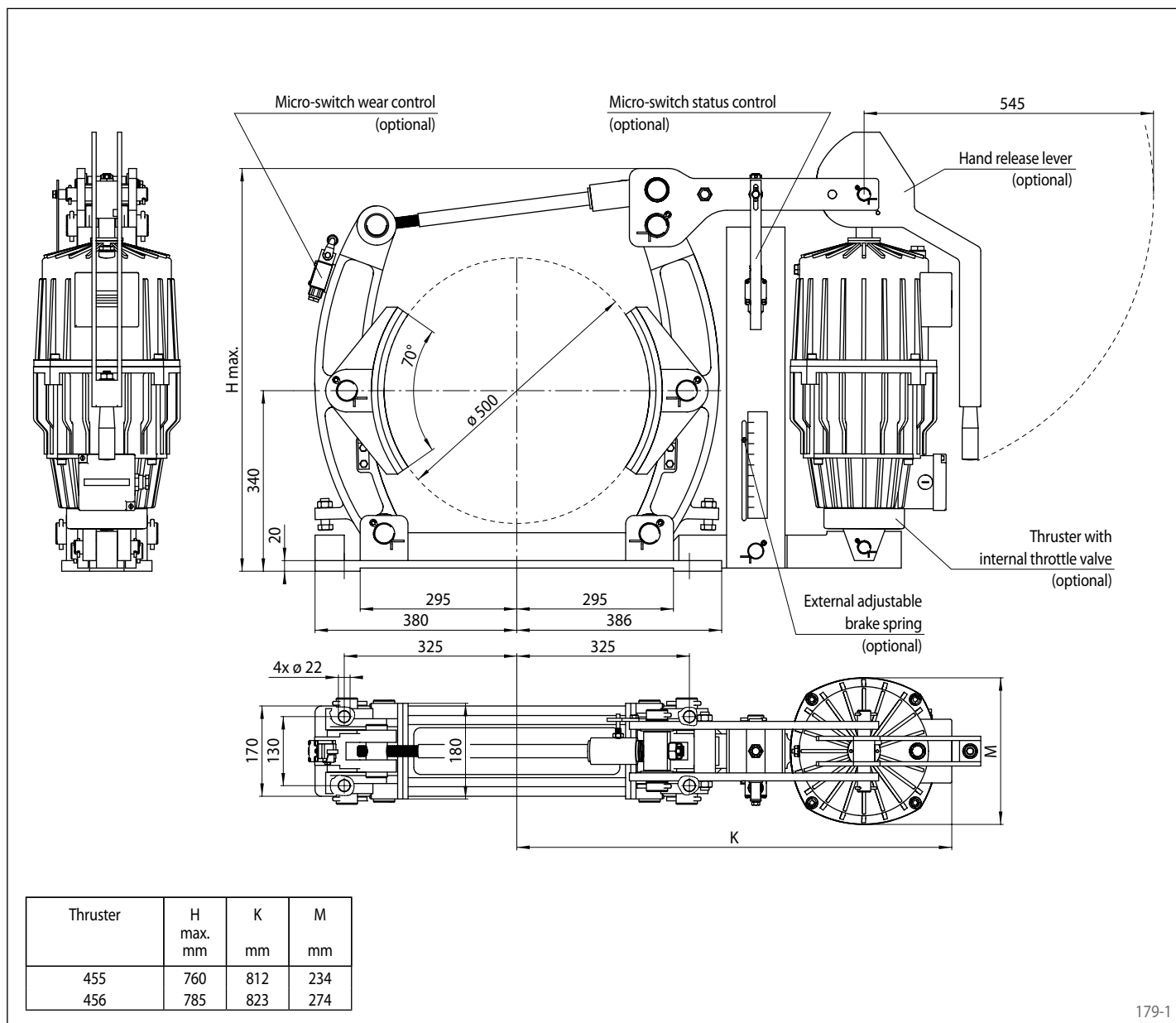

179-1

Options

- External adjustable brake spring
- Micro-switch wear control
- Micro-switch status control
- Hand release lever
- Thruster with internal throttle valve
- Thruster in heat resistant design
- Corrosion protected design
- Wider brake shoes and brake drums

Brake Caliper DT 500 FEA ... ST

spring activated – electrohydraulically released
 Drum Brake according to DIN 15 435



Features	Code
Brake Caliper	D
Drum Brake	T
Frame size 500	500
Spring activated	F
Electrohydraulically released	E
Automatic adjustment to accommodate friction block wear	A
Thrusters 453, 455 or 456 are available	453 455 456
Material: steel	ST

Example for ordering

Brake Caliper DT 500 FEA, thruster 456, material: steel

DT 500 FEA - 456 - ST

Technical Data

	Brake Caliper DT 500 FEA... ST		
	with thruster 453	with thruster 455	with thruster 456
Brake drum diameter	Braking torque	Braking torque	Braking torque
mm	Nm	Nm	Nm
500	1 600	3 100	5 120
Clamping force	8 000 N	15 500 N	25 600 N
Braking torque adjustable (optional)	20 - 100%	20 - 100%	20 - 100%
Nominal power	240 W	370 W	590 W
Oil volume	3,5 l	4,5 l	11 l
Voltage	230/400 V	230/400 V	230/400 V
Weight	165 kg	171 kg	197 kg

The braking torques shown in the table are based on a theoretical friction coefficient of 0,4.

Brake Caliper DT 500 FEA ... ST

spring activated – electrohydraulically released
 Drum Brake according to DIN 15 435

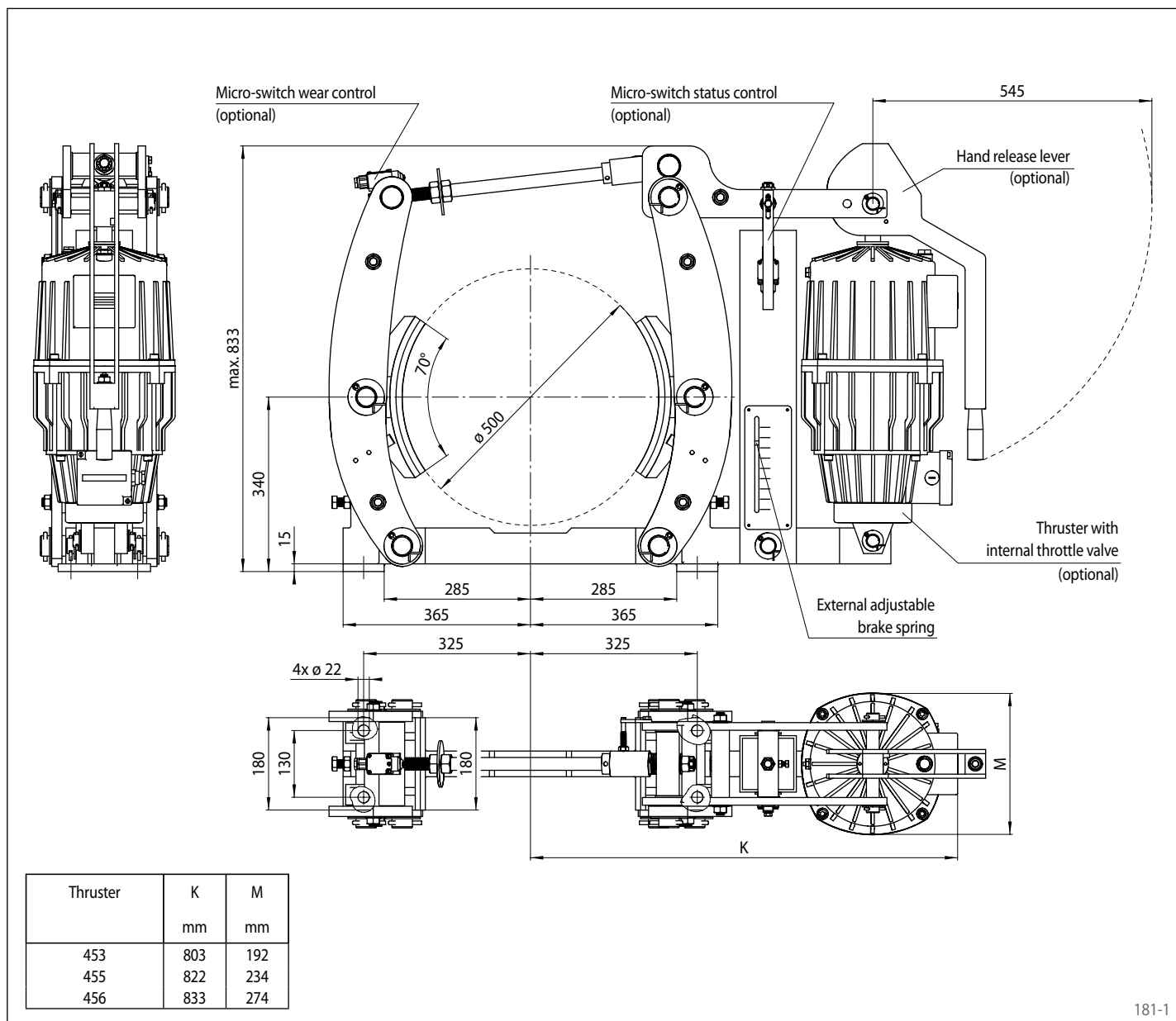

181-1

Options

- Micro-switch wear control
- Micro-switch status control
- Hand release lever
- Thruster with internal throttle valve
- Thruster in heat resistant design
- Corrosion protected design
- Wider brake shoes and brake drums

Brake Caliper DT 630 FEA ... ST

spring activated – electrohydraulically released
 Drum Brake according to DIN 15 435



Features	Code
Brake Caliper	D
Drum Brake	T
Frame size 630	630
Spring activated	F
Electrohydraulically released	E
Automatic adjustment to accommodate friction block wear	A
Thrusters 455, 456 or 457 are available	455 456 457
Material: steel	ST

Example for ordering

Brake Caliper DT 630 FEA, thruster 457, material: steel

DT 630 FEA - 457 - ST

Technical Data

	Brake Caliper DT 630 FEA ... ST		
	with thruster 455	with thruster 456	with thruster 457
Brake drum diameter	Braking torque	Braking torque	Braking torque
mm	Nm	Nm	Nm
630	3 100	5 000	7 200
Clamping force	12 300 N	19 800 N	28 600 N
Braking torque adjustable	20 - 100%	20 - 100%	20 - 100%
Nominal power	370 W	590 W	680 W
Oil volume	4,5 l	11 l	11 l
Voltage	230/400 V	230/400 V	230/400 V
Weight	231 kg	257 kg	259 kg

The braking torques shown in the table are based on a theoretical friction coefficient of 0,4.

Brake Caliper DT 630 FEA ... ST

spring activated – electrohydraulically released
 Drum Brake according to DIN 15 435

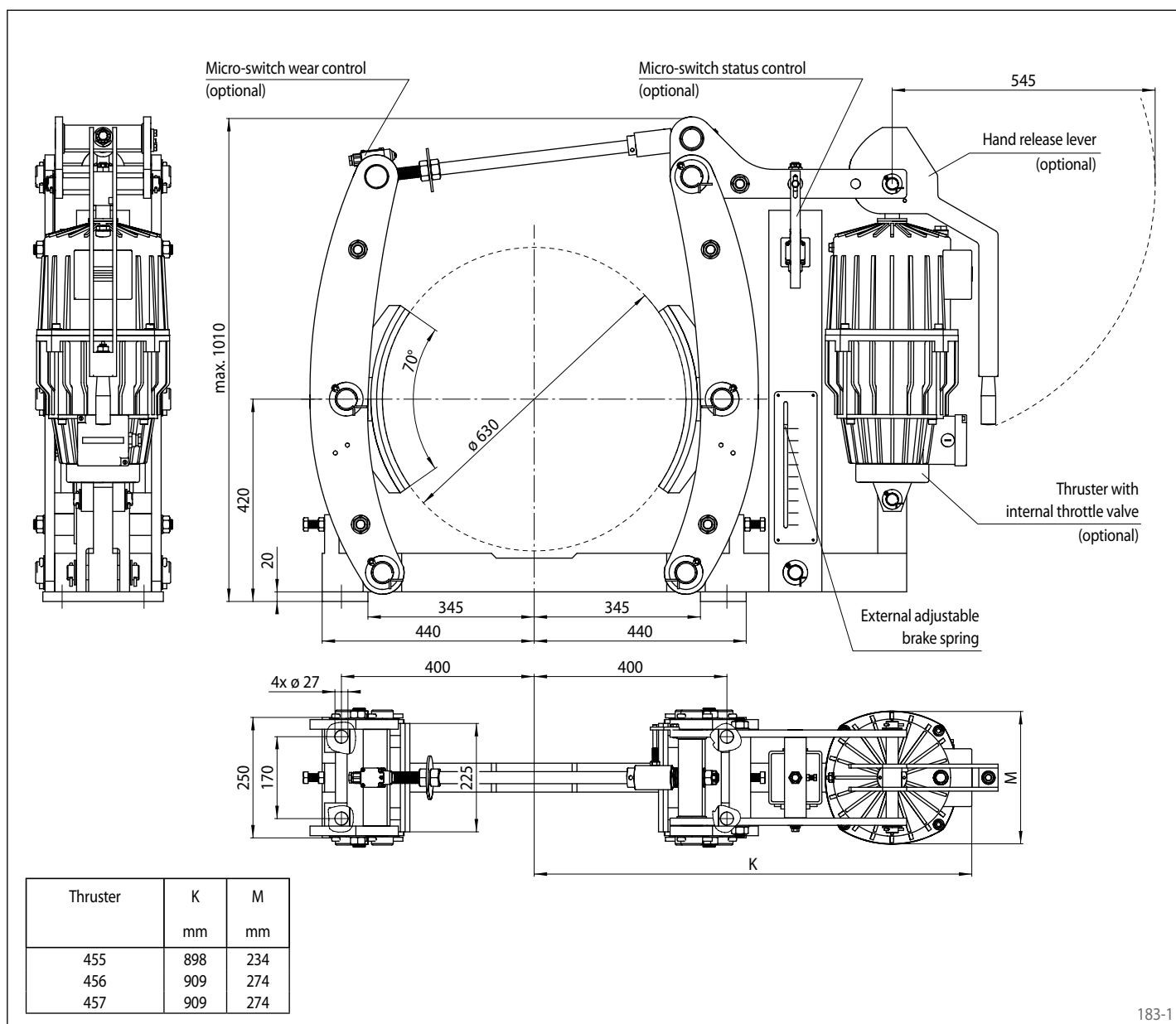

Options

- Micro-switch wear control
- Micro-switch status control
- Hand release lever
- Thruster with internal throttle valve
- Thruster in heat resistant design
- Corrosion protected design
- Wider brake shoes and brake drums

Rail Brake HR 130 FHK

spring activated – hydraulically released

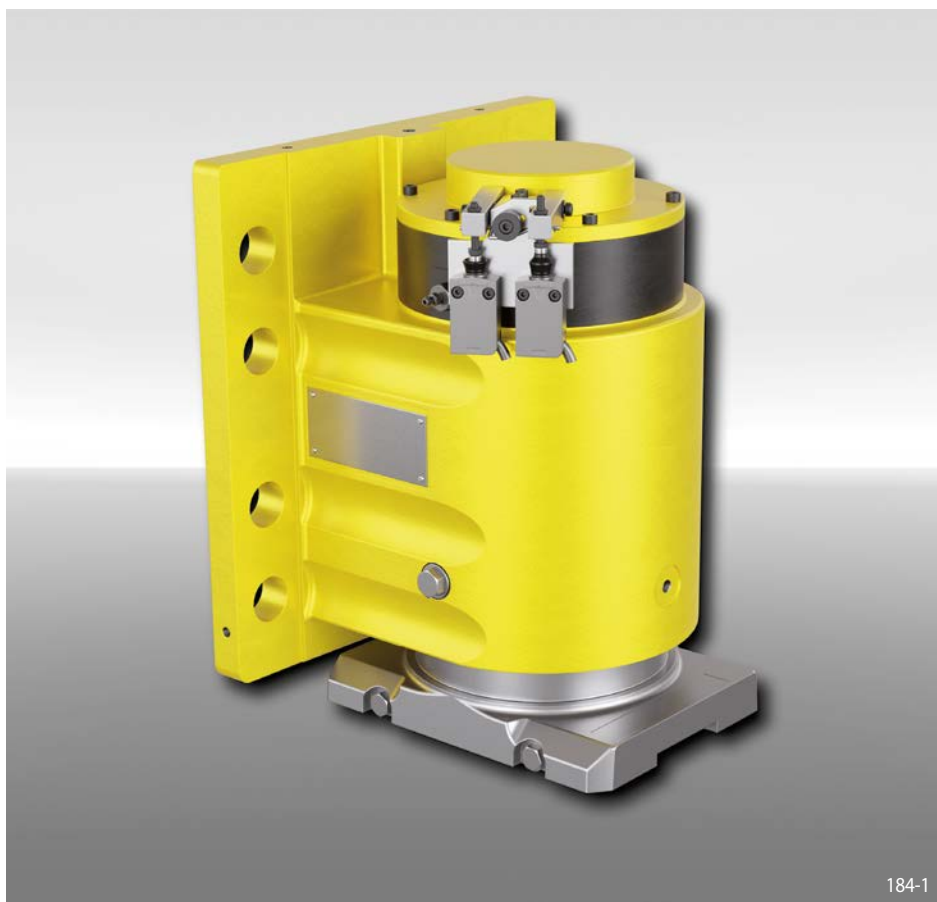

184-1

Features

Code

Brake	H
Rail	R
Frame size 130	130
Spring activated	F
Hydraulically released	H
No adjustment to accommodate friction block wear	K
Max. clamping force 50 kN or 200 kN	050 200

Example for ordering

Rail Brake HR 130 FHK, max. clamping force 200 kN:

HR 130 FHK-200

Technical Data

	Rail Brake HR 130 FHK	
	with clamping force 050	with clamping force 200
Braking force	27,3 kN	110 kN
Clamping force on the rail	50 kN	200 kN
Nominal pad gap (total)	5 mm	5 mm
Oil pressure	min. 60 bar max. 230 bar	min. 210 bar max. 230 bar
Oil volume	max. 90 cm ³	max. 90 cm ³
Weight	130 kg	130 kg

Rail Brake HR 130 FHK

RINGSPANN®

spring activated – hydraulically released

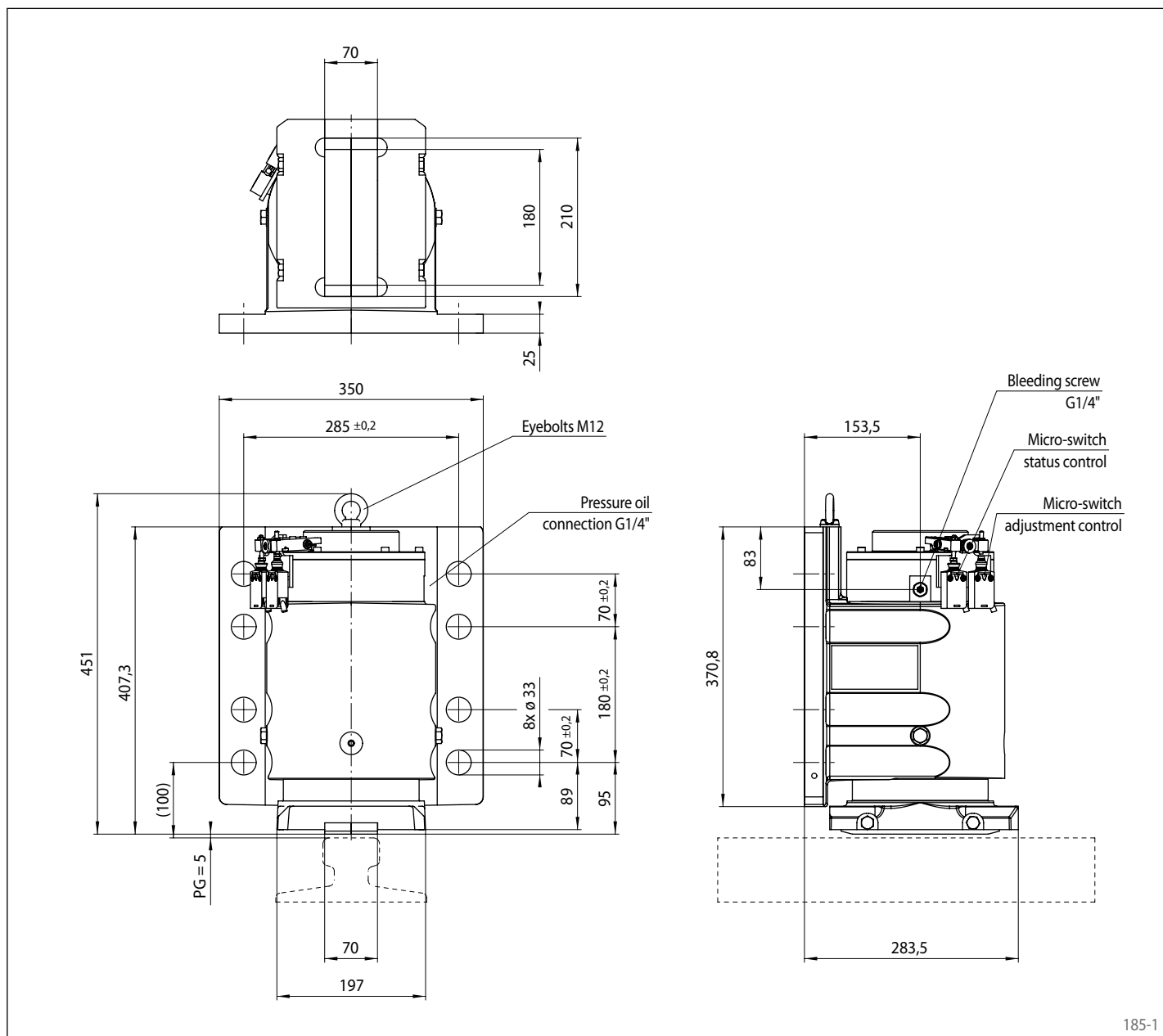

185-1

Working conditions

- Ambient temperature: -20 °C / +60 °C
- Air humidity: <90%

Monitoring switch

- 240 VAC 1.5 A; 250 VDC 0.1 A
- Cable 5 x 0.75 mm², length 2 m, outer diameter 7.5 mm
- Protection type IP67

Options

- Assembly set (screw and washers)
- Stainless steel cover
- Seawater execution

Notes

- Fastening:
 - 8 screws M 30 class 8.8 (optional)
 - Cs: 1 280 Nm +/- 5%; μ=0,15

Rail Brake HR 185 FHK

spring activated – hydraulically released

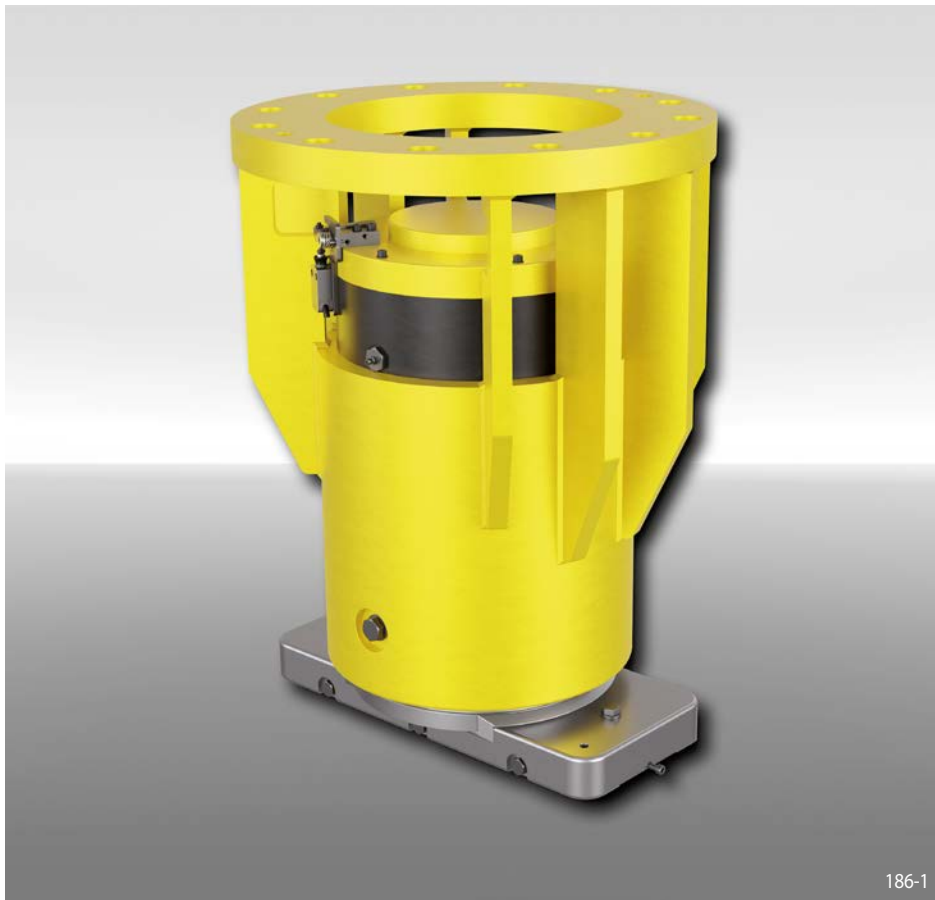

186-1

Features

Features	Code
Brake	H
Rail	R
Frame size 185	185
Spring activated	F
Hydraulically released	H
No adjustment to accommodate friction block wear	K
Max. clamping force 530 kN	530

Example for ordering

Rail Brake HR 185 FHK, max. clamping force 530 kN:

HR 185 FHK-530

Technical Data

Braking force	300 kN
Clamping force on the rail	530 kN
Nominal pad gap (total)	10 mm
Oil pressure	min. 230 bar max. 250 bar
Oil volume	max. 450 cm ³
Weight	430 kg

Rail Brake HR 185 FHK

RINGSPANN®

spring activated – hydraulically released

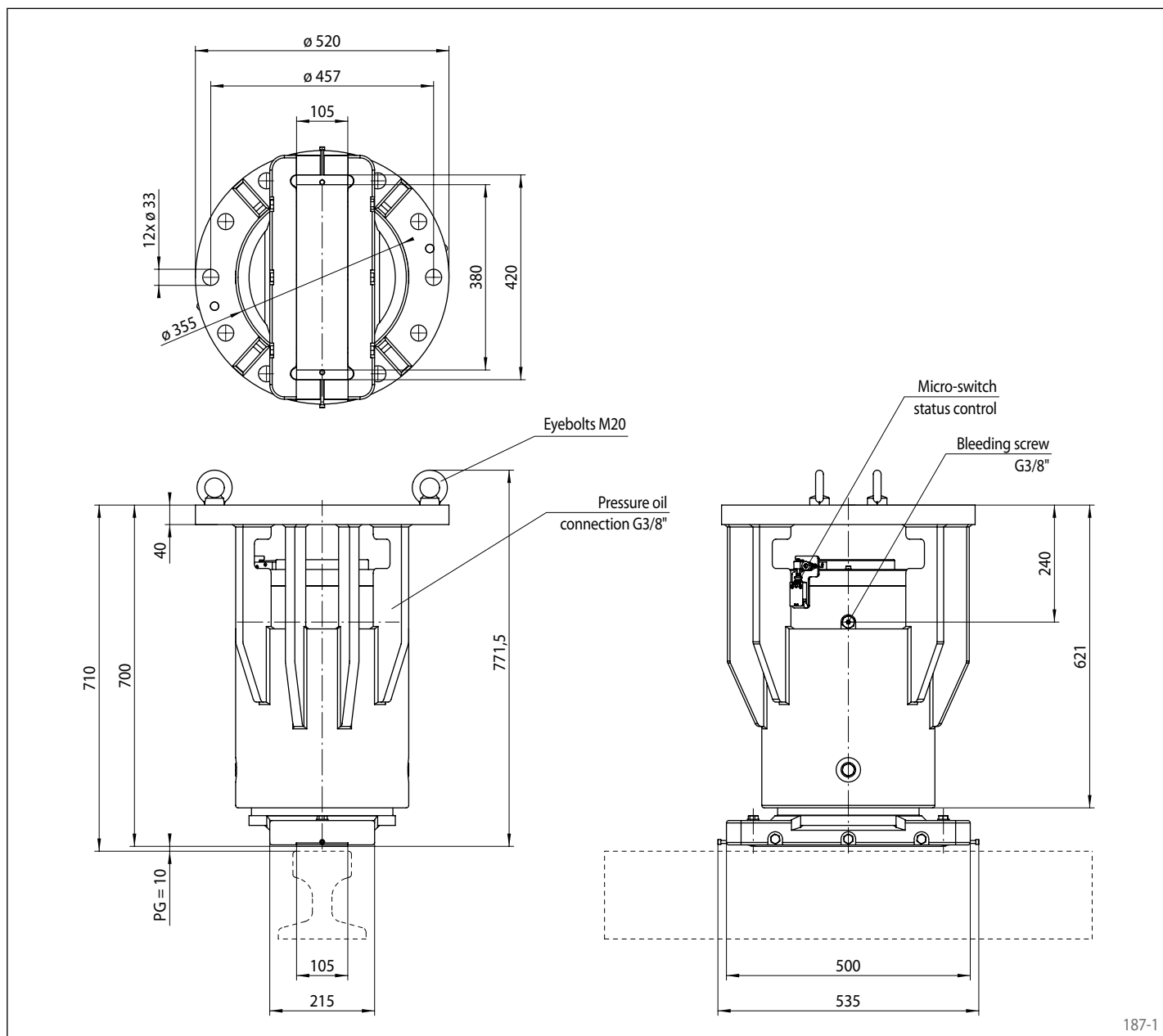

187-1

Working conditions

- Ambient temperature: -20 °C / +60 °C
- Air humidity: <90%

Monitoring switch

- 240 VAC 1.5 A; 250 VDC 0.1 A
- Cable 5 x 0.75 mm², length 2 m, outer diameter 7.5 mm
- Protection type IP67

Options

- Assembly set (screw and washers)
- Stainless steel cover
- Seawater execution

Notes

- Fastening:
 - 12 screws M 30 class 8.8 (optional)
 - Cs: 1350 Nm +/- 5%; $\mu=0,15$

Rail Clamp DR 085 FHK

spring activated – hydraulically released

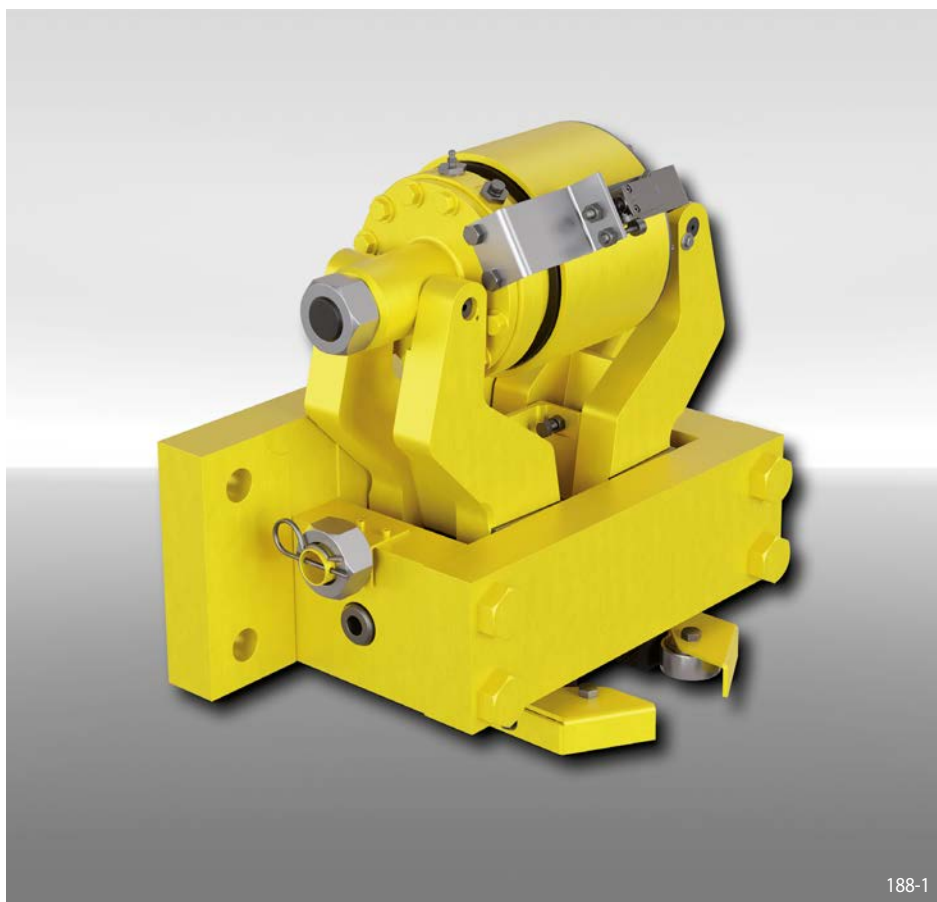

188-1

Features	Code
Clamp	D
Rail	R
Frame size 085	085
Spring activated	F
Hydraulically released	H
No adjustment to accommodate friction block wear	K
Max. braking forces for holding of 50 kN, 100 kN, 200 kN, 300 kN or 400 kN	050 to 400
Thruster mounted in central position	M
Clamping jaws are available for rail profiles A55, A65, A75, A100, A120 or 60E1	A55 A65 A75 A100 A120 60E1

Technical Data

	Rail Clamp DR 085 FHK				
	with braking force 050	with braking force 100	with braking force 200	with braking force 300	with braking force 400
Braking force	50 kN	100 kN	200 kN	300kN	400 kN
Nominal pad gap (total)	3 mm	3 mm	2,5 mm	2 mm	1,6 mm
Oil pressure	min. 110 bar max. 130 bar	min. 110 bar max. 130 bar	min. 105 bar max. 130 bar	min. 105 bar max. 130 bar	min. 115 bar max. 130 bar
Oil volume	max. 80 cm ³	max. 80 cm ³	max. 220 cm ³	max. 220 cm ³	max. 220 cm ³
Weight	210 kg	210 kg	238 kg	238 kg	238 kg

Example for ordering

Rail Clamp DR 085 FHK, max. braking force 100 kN, thruster mounted in central position and rail profile A55:

DR 085 FHK-100 M-A55

Rail Clamp DR 085 FHK

spring activated – hydraulically released

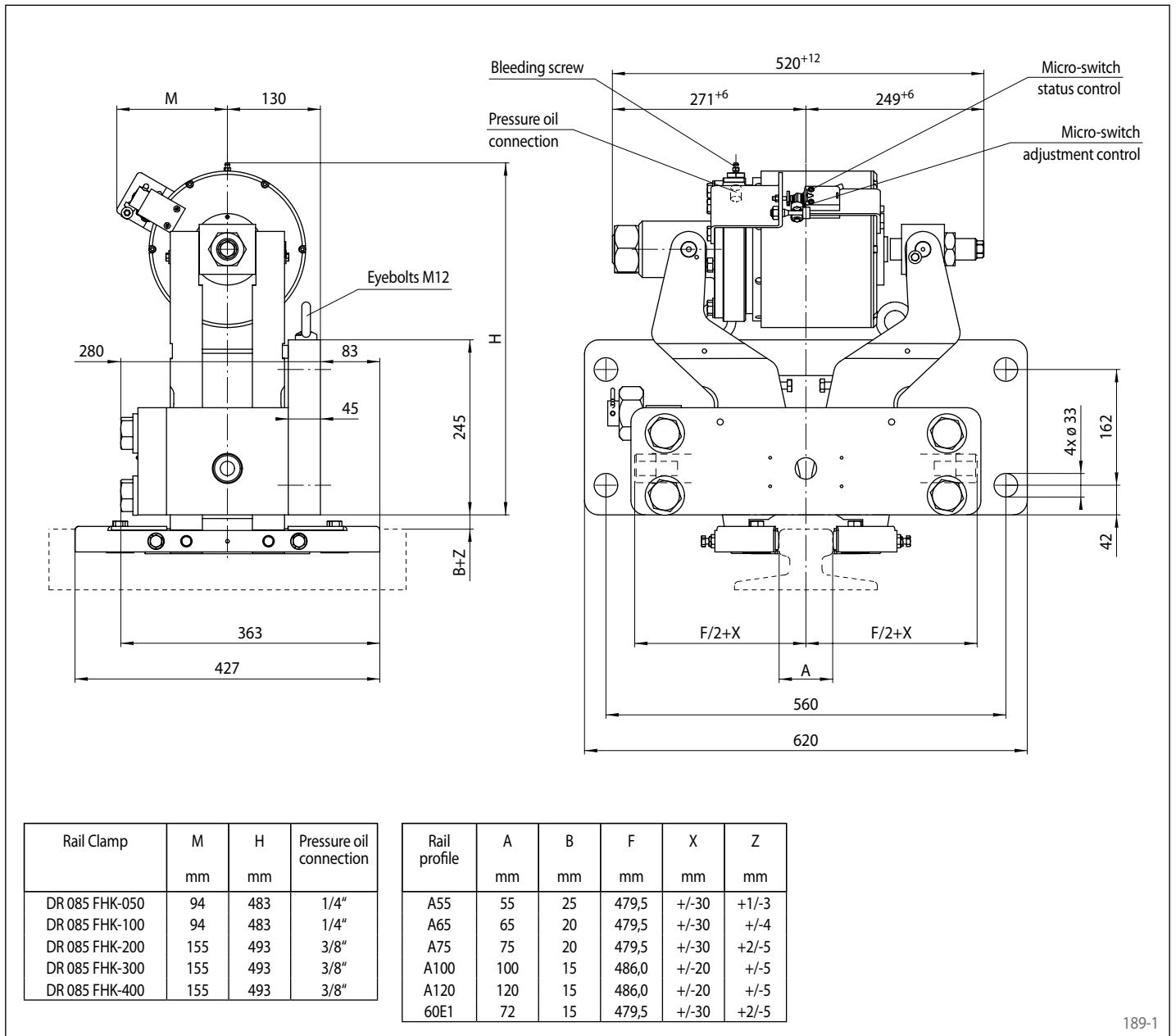

189-1

Working conditions

- Ambient temperature: -20 °C / +40 °C
- Air humidity: <90%

Monitoring switch

- 240 VAC 1.5 A; 250 VDC 0.1 A
- Cable 5 x 0.75 mm², length 2 m, outer diameter 7.5 mm
- Protection type IP67

Options

- Protection cover
- Integrated hydraulic power unit
- Offshore certifications
- Seawater execution
- Flat pads for dynamic braking

Notes

- Fastening:
 - 4 screws M 30 class 10.9 (optional)
 - Cs: 1515 Nm +/- 5%; μ=0,10

Rail Clamp DR 088 FHK

spring activated – hydraulically released

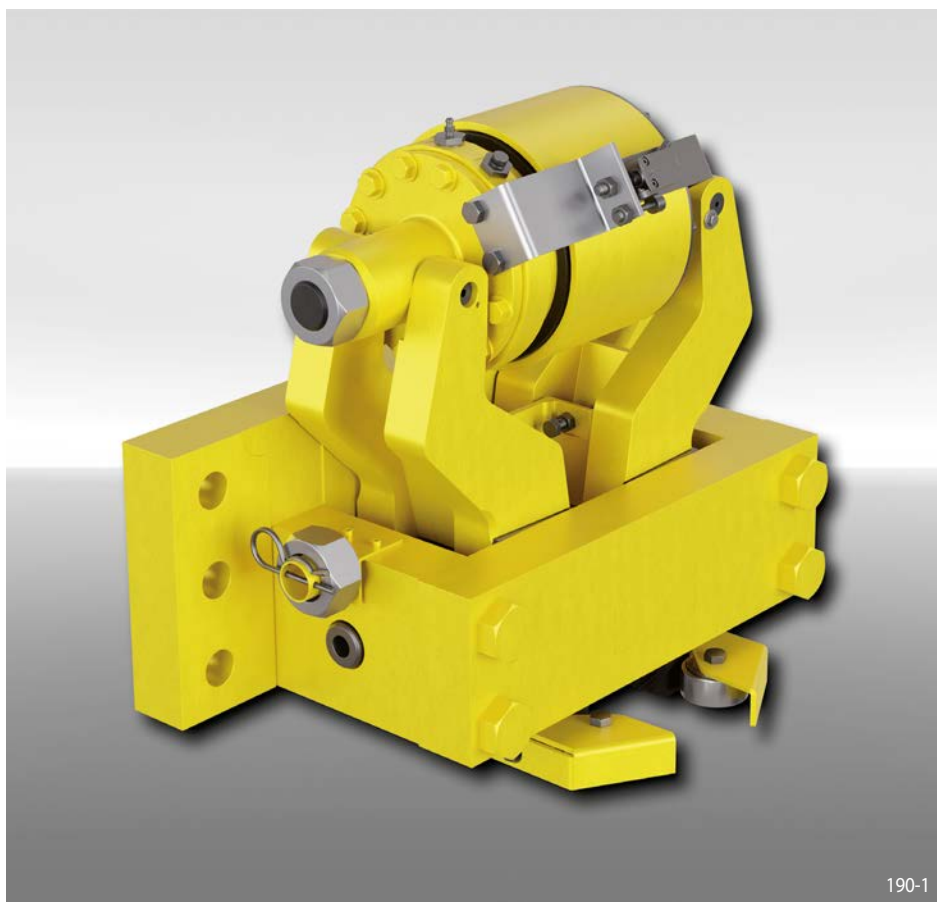

Features	Code
Clamp	D
Rail	R
Frame size 088	088
Spring activated	F
Hydraulically released	H
No adjustment to accommodate friction block wear	K
Max. braking force 500 kN	500
Thruster mounted in central position	M
Clamping jaws are available for rail profiles A55, A65, A75, A100, A120 or 60E1	A55 A65 A75 A100 A120 60E1

Technical Data

Braking force	500 kN
Nominal pad gap (total)	2 mm
Oil pressure	min. 110 bar max. 130 bar
Oil volume	max. 220 cm ³
Weight	290 kg

Example for ordering

Rail Clamp DR 088 FHK, max. braking force 500 kN, thruster mounted in central position and rail profile A55:

DR 088 FHK-500 M-A55

Rail Clamp DR 088 FHK

spring activated – hydraulically released

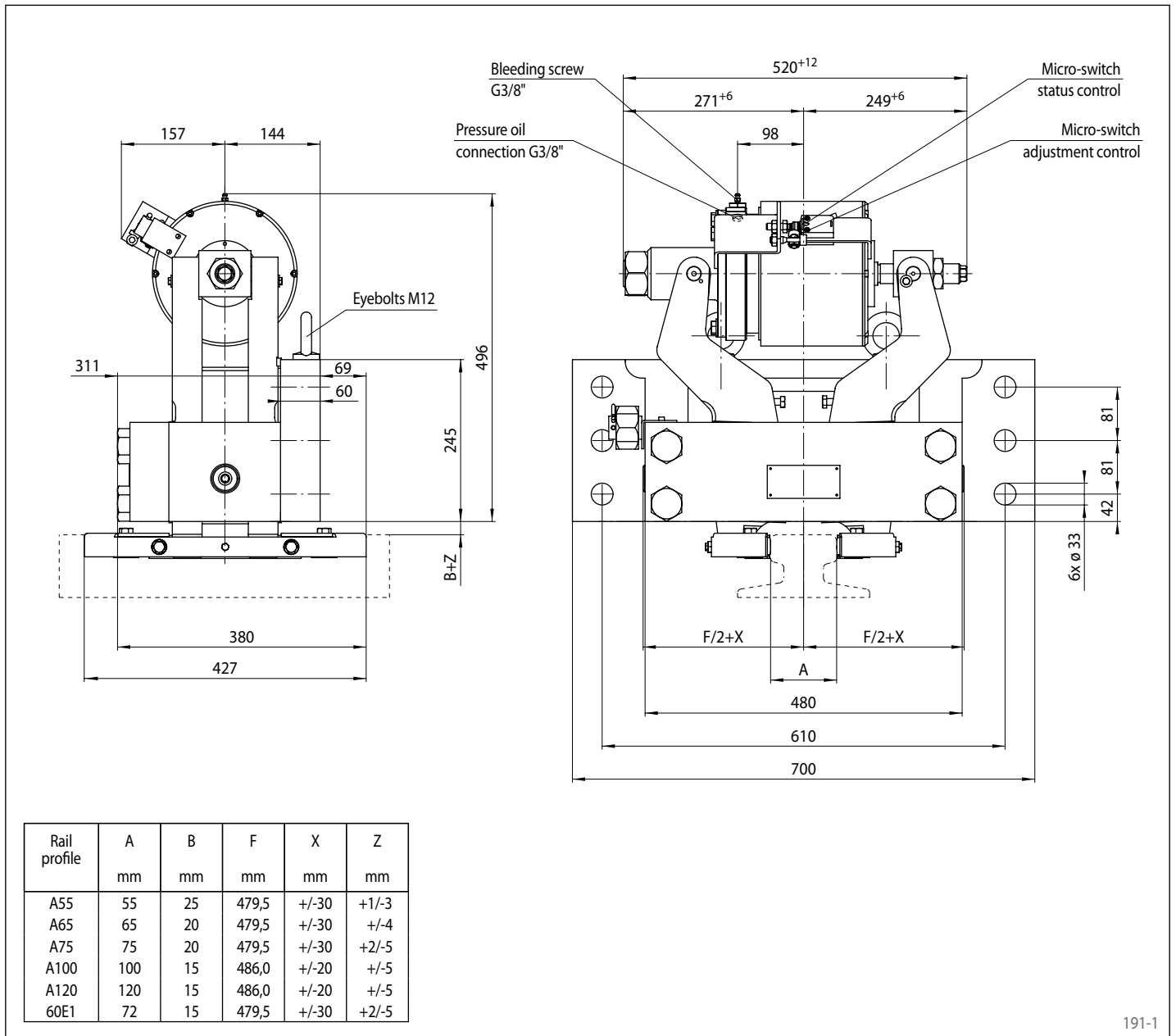

191-1

Working conditions

- Ambient temperature: -20 °C / +40 °C
- Air humidity: <90%

Monitoring switch

- 240 VAC 1.5 A; 250 VDC 0.1 A
- Cable 5 x 0.75 mm², length 2 m, outer diameter 7.5 mm
- Protection type IP67

Options

- Protection cover
- Integrated hydraulic power unit
- Offshore certifications
- Seawater execution
- Flat pads for dynamic braking

Notes

- Fastening:
 - 6 screws M 30 class 10.9 (optional)
 - Cs: 1515 Nm +/- 5% ; μ=0,10



Features	Code
Brake Disc	B
Form	F B S
Size of Brake Discs according to table	0125 to 1000
Thickness of brake disc (Standard)	12 25
Bore diameter according to table	014 to 220
Form pre drilled, finished bore without keyway, finished bore with keyway	V F B

Example for ordering

Brake Disc BF with a size of Brake Disc 200 mm, thickness of brake disc 12,5 mm and bore diameter 40 mm in Form F:

BF 0200/12 - 040 F

Technical Data

Size	Thickness of brake disc	Max. speed	Form F	Form B	Form S*		
			Inertia moment	Inertia moment	Clamping diameter	Inertia moment	Max. braking torque
D mm	W mm	n_{max} min ⁻¹	J kgm ²	J kgm ²	d mm	J kgm ²	M_{max} Nm
125	12,5	14 500	0,0022	0,0023	-	-	-
150	12,5	12 100	0,0045	0,0047	-	-	-
200	12,5	9 100	0,0141	0,0146	-	-	-
250	12,5	7 300	0,0345	0,0380	-	-	-
300	12,5	6 000	0,0720	0,0800	80	0,078	950
355	12,5 / 25	5 100	0,140 / 0,270	0,162 / 0,243	-	-	-
430	12,5 / 25	4 200	0,302 / 0,596	0,352 / 0,638	90	0,305	1 500
					140	0,405	3 750
					160	0,646	6 000
520	12,5 / 25	3 500	0,646 / 1,273	0,790 / 1,380	140	0,752	3 750
					160	0,990	6 000
					200	1,431	9 500
630	25	2 900	2,780	3,130	-	-	-
710	25	2 600	4,490	5,090	-	-	-
800	25	2 300	7,240	8,420	-	-	-
900	25	2 000	11,59	13,70	-	-	-
1 000	25	1 800	17,70	21,30	-	-	-

* Only available in thickness of brake disc W = 12,5 mm

Features

- Optimized for use with RINGSPANN Brakes
- Cast material for best heat absorption
- Ready to install versions are available
- Variants with finished bore, keyway or shrink disc
- Disc diameter ranging from 125 mm to 1000 mm
- The Brake Disc are made from EN 1563 EN-GJS500-7 (GGG-50 after DIN 1693)
- Other sizes of Brake Discs are available on request

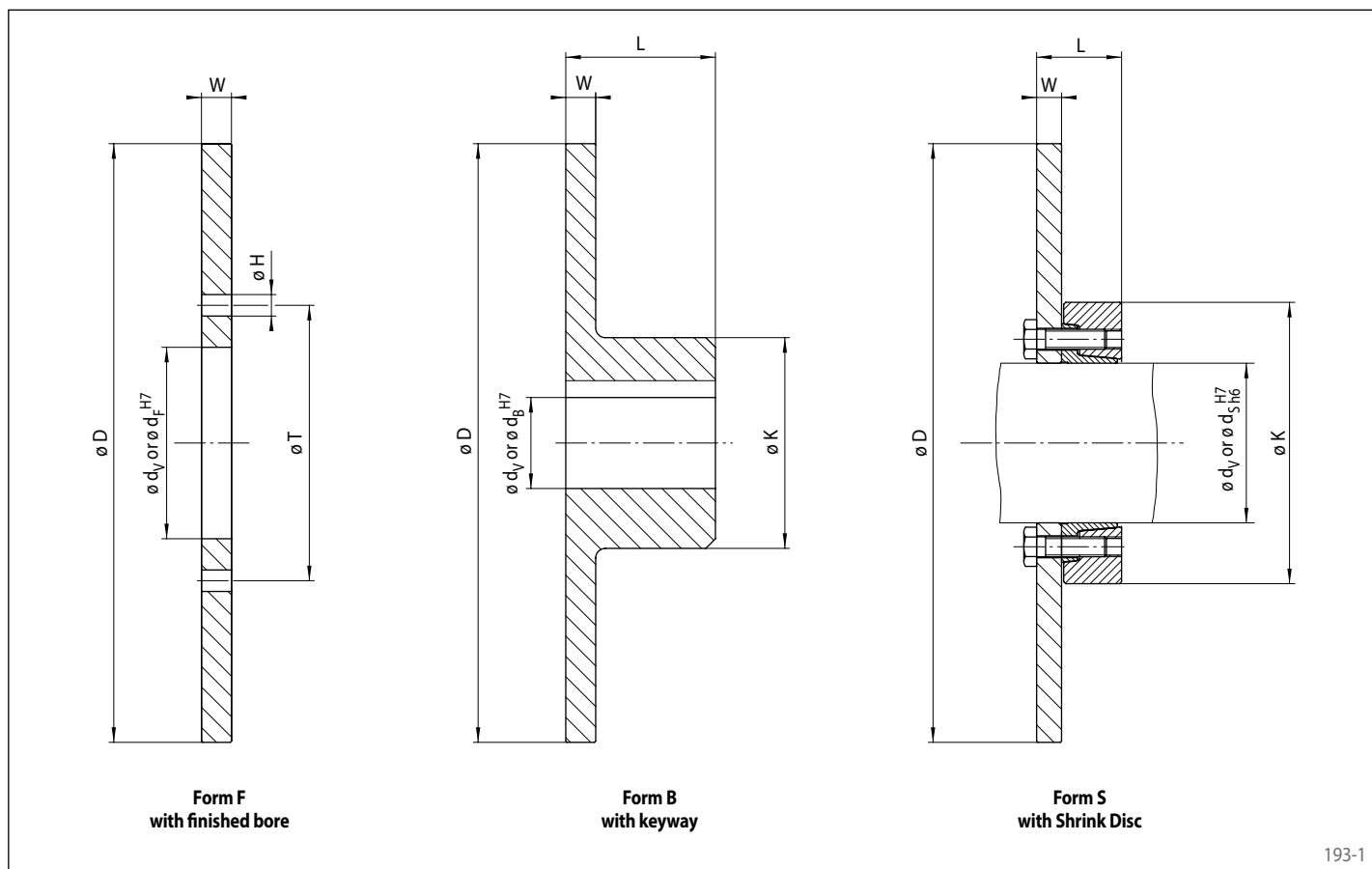

193-1

Dimensions

Size	Thickness of brake disc	Pre drilled	Form F				Form B			Form S		
			Finished bore d _F	H	T	Z*	Finished bore d _B **	L	K	Clamping diameter d _S	L***	K
D mm	W mm	d _V mm	d _F mm	H mm	T mm	Z*	d _B ** mm	L mm	K mm	d _S mm	L*** mm	K mm
125	12,5	-	40	9	56	4	32	37,5	50	-	-	-
150	12,5	-	50	9	66	4	40	42,5	60	-	-	-
200	12,5	-	63	11	83	8	45	52,5	65	-	-	-
250	12,5	-	80	11	100	8	70	62,5	100	-	-	-
300	12,5	-	100	14	122	8	80	72,5	120	80	46,5	141
355	12,5 / 25	-	110	14	132	10	100	82,5	145	-	-	-
430	12,5 / 25	50	125	14	147	12	115	97,5	170	90	52,5	155
										140	74,5	230
										160	84,5	290
520	12,5 / 25	50	160	14	182	16	140	117,5	210	140	74,5	230
										160	84,5	290
										200	101,5	340
630	25	75	-	-	-	-	155	150	250	-	-	-
710	25	95	-	-	-	-	180	165	280	-	-	-
800	25	95	-	-	-	-	200	185	320	-	-	-
900	25	120	-	-	-	-	210	205	360	-	-	-
1 000	25	120	-	-	-	-	220	225	400	-	-	-

* Z = Number of holes øH pitch circle øT • ** Keyway according to DIN 6885, page 1 • *** At unclamped state

Brake Discs Form S

The following apply to the shaft:

- Yield strength $R_e \geq 360 \text{ N/mm}^2$
- E-module ca. 206 kN/mm^2

Surfaces

Average surface roughness at the contact surfaces of the shaft $R_a \leq 3,2 \mu\text{m}$.

Dimensioning

Please refer to the technical points on page 195 when dimensioning the brake disc size.

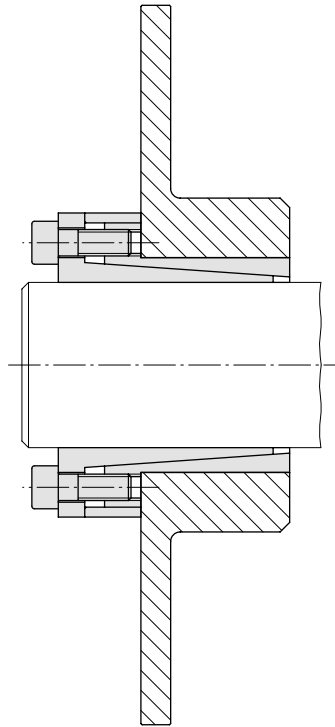

**Cone Clamping Element RLK 110
with Brake Disc Form B**

194-1

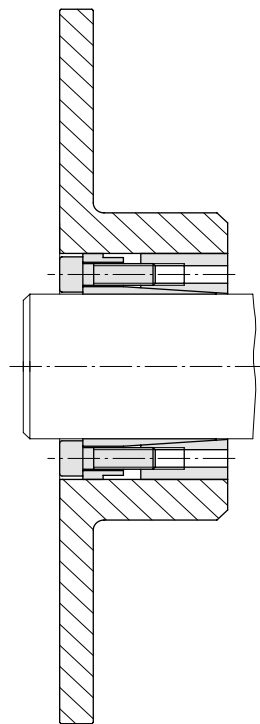

**Cone Clamping Element RLK 130
with Brake Disc Form B**

194-2

Brake Discs

Verification of Heat Absorption

Permissible Braking Action with Single Braking Operation

Extreme braking processes should be checked to ensure that the brake disc will not reach 300° C when absorbing the braking energy. The braking time in this case should not exceed 10 seconds.

As an example, you can see in the table the braking energy a brake disc can absorb together with a brake size 020/025/030 without exceeding 300° C. We recommend that this additional calculation be carried out in the case of indexing operations. The absorbed energy

for the deceleration of rotating masses in this case is:

$$W_B = \frac{J_{red} (n_1^2 - n_2^2)}{182,5}$$

Ensure that:

$$W_{BSzul} \geq W_B$$

The table is valid for brake disc material GJS-500, brake sizes 020/025/030 with standard friction pads, a maximum brake disc temperature of 300° C and ambient temperature of 20° C.

D	W _{BSzul}	W _{BSzul}
	W = 12,5 mm Nm	W = 25 mm Nm
125	120 000	-
150	170 000	-
200	260 000	-
250	350 000	-
300	450 000	-
355	550 000	1 090 000
430	690 000	1 370 000
520	850 000	1 700 000
630	-	2 110 000
710	-	2 410 000
800	-	2 740 000
900	-	3 110 000
1 000	-	3 480 000

Verification of Heat Dissipation

The transmissible brake power of the disc according to the diagram on this page applies to the types of braking operation described below:

$$P_{BSzul} \geq P_B$$

Braking with low frequency z ≤ 40 per hour

If „z“ actuations occur within one hour, then the brake power capacity required is as follows:

$$P_B = \frac{M_B (n_1 - n_2)}{6,88 \cdot 10^7} \cdot z \cdot t_B$$

Braking with high frequency z > 40 per hour

For such cases we would ask you to enclose with your enquiry exact details of the time slope of speed and braking torque, as well as the completed questionnaire on page 210. We will check the design of the brake disc in respect of the heat dissipation.

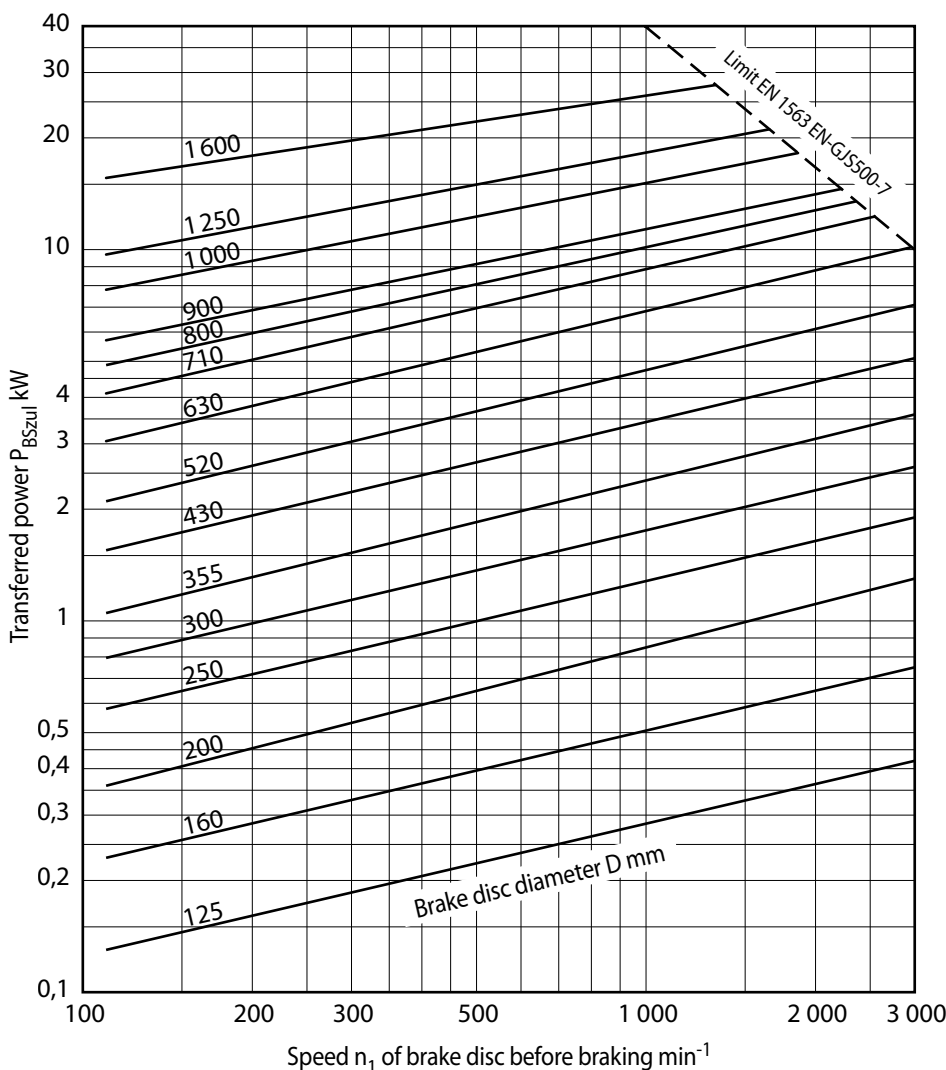

Formula symbols

- J_{red} [kg m²] Reduced inertia moment
- M_B [Nm] Required braking torque
- n₁ [min⁻¹] Speed before braking
- n₂ [min⁻¹] Speed after braking
- P_B [kW] Brake power generated by application, average with one braking cycle
- P_{BSzul} [kW] Brake power capacity of brake
- t_B [s] Braking time
- W [mm] Thickness of brake disc
- W_B [Nm] Braking energy generated by application
- W_{BSzul} [Nm] Braking energy capacity of the disc brake
- z [h⁻¹] Number of braking cycles per hour

The transferred power is based on a maximum disc temperature of 300° C applicable to thickness of brake disc of up to 25 mm and an ambient temperature of 20° C.

Friction Block Wear Control

Function

All brakes can be supplied on request with an electrical wear indicator which signals the limit of the friction block wear. The control lamp in the wear monitor indicates when the friction blocks need to be replaced. In addition, the output relay can trigger a signal in the central control station.

Friction Blocks with Signal Cable

Friction blocks with signal cable are used to monitor wear. Cable length 25 cm with plug connection.

Wear indicator

Housing: Makrolon
 Insulation: IP 65
 Colour: Grey, RAL 7035
 Temperature range: -50° C to 60° C
 Output: Relay 6A / 230 V AC

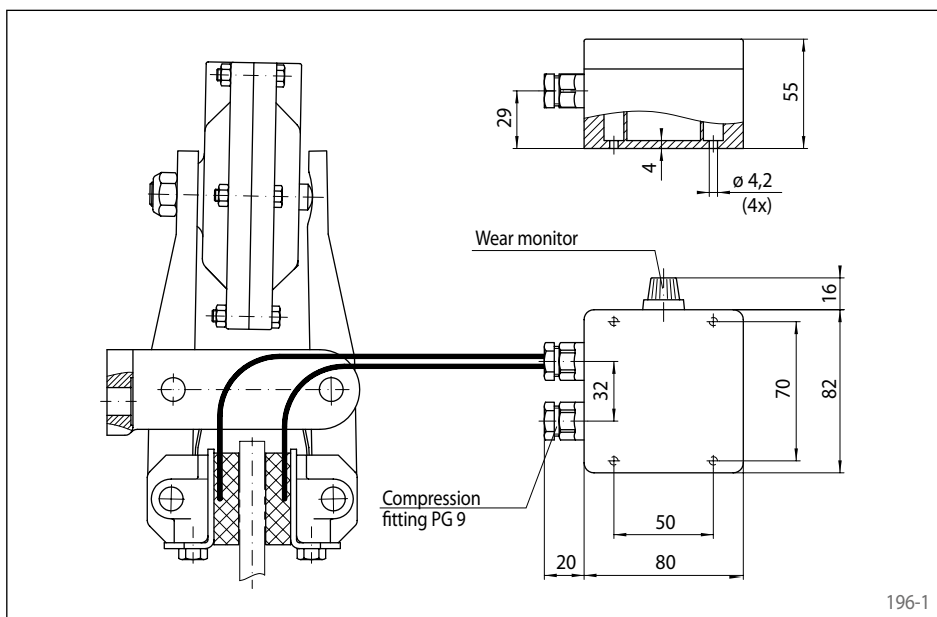

Article Number for supply voltage	
24 V DC	230 V AC, 50 Hz
3511-000001-B024VG	3511-000001-B220VW

Universal Transformer

The Universal Transformer is used to operate a DH 012 FEM or DV 020 FEM Brake Caliper.

Output: 0,25 kVA

Primary voltages:

200 V, 220 V, 240 V, 260 V, 280 V, 300 V, 310 V, 330 V, 350 V, 360 V, 380 V, 400 V, 420 V, 440 V, 480 V, 500 V, 530 V and 550 V

Secondary voltages:

115 V or 230 V

The Universal Transformer is manufactured in accordance with EN 61558 / VDE 0570:

- Clamps in accordance with VDGB-4
- Insulation class T40/E
- Safety class 1

Article Number: 3503-000001-000000

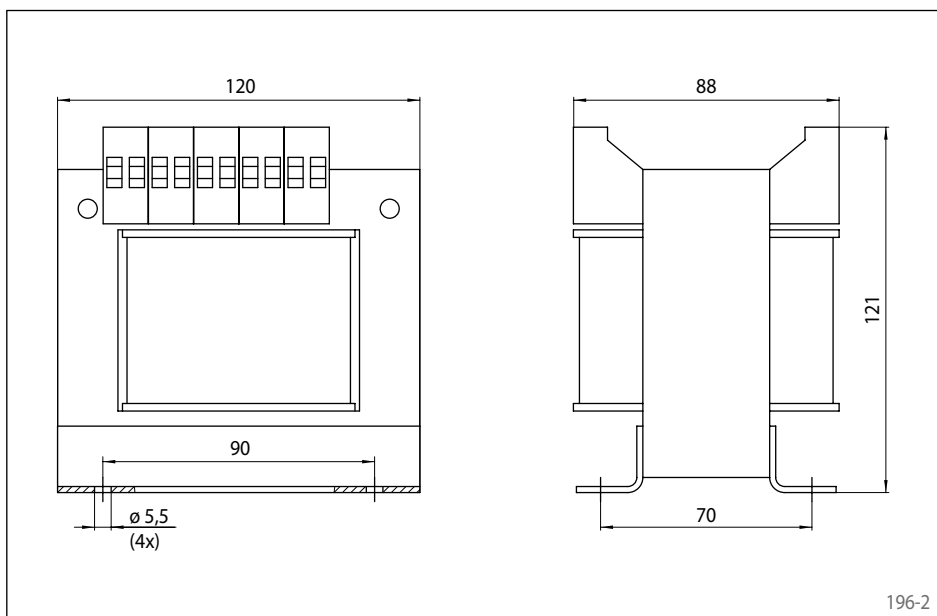

RCS® Pull Cable and RCS® Hand Brake Lever

RCS® Pull Cable

RCS® Pull Cable for Brake Calipers DV 020 FKM and DH 020 FKM as well as DV 020 MKM and DH 020 MKM are available in variable cable lengths.

Cable ends are designed for attachment to Brake Calipers or RCS® Hand Brake Lever B 50452.

Features

- Slide ease
- Stainless steel inner member wrap
- Suitable for small bending radii
- Galvanized steel elements
- Stainless steel drawbar

An extensive product range of RCS® Remote Control Systems can be found in the "RCS® Remote Control Systems" catalogue.

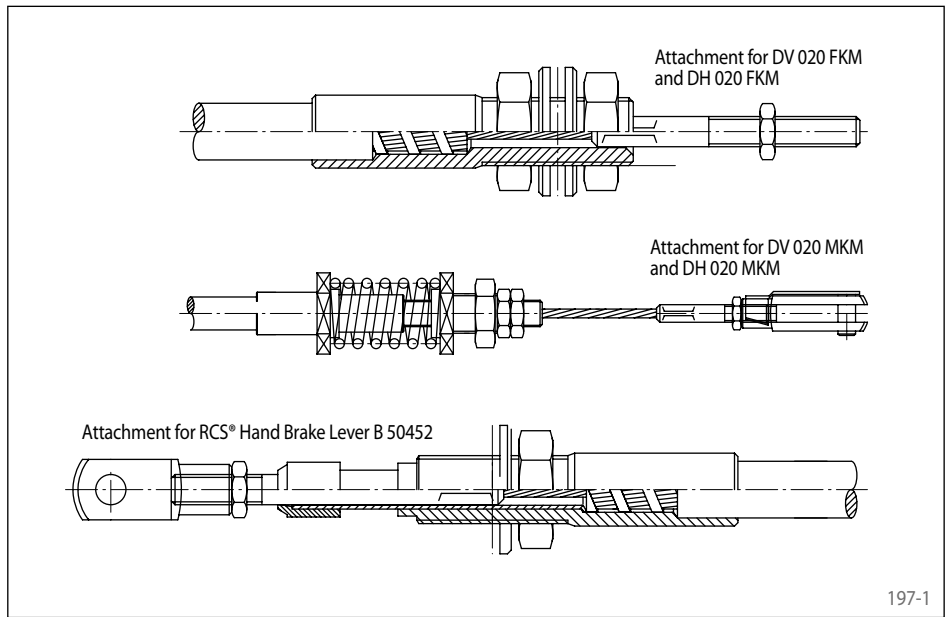

197-1

RCS® Hand Brake Lever B 50452

The RCS® Hand Brake Lever B 50452 is used to operate Brake Calipers DV 020 FKM and DH 020 FKM as well as DV 020 MKM and DH 020 MKM in connection with a RCS® Cable.

Article Number: 4561-000001-R50452

Features

- Two positions: "open" or "closed"
- Over center locking
- Friction Block Wear compensation
- Attachment for RCS® Pull Cables
- Optional with electric switch (Closer or Opener) available

An extensive product range of RCS® Remote Control Systems can be found in the "RCS® Remote Control Systems" catalogue.

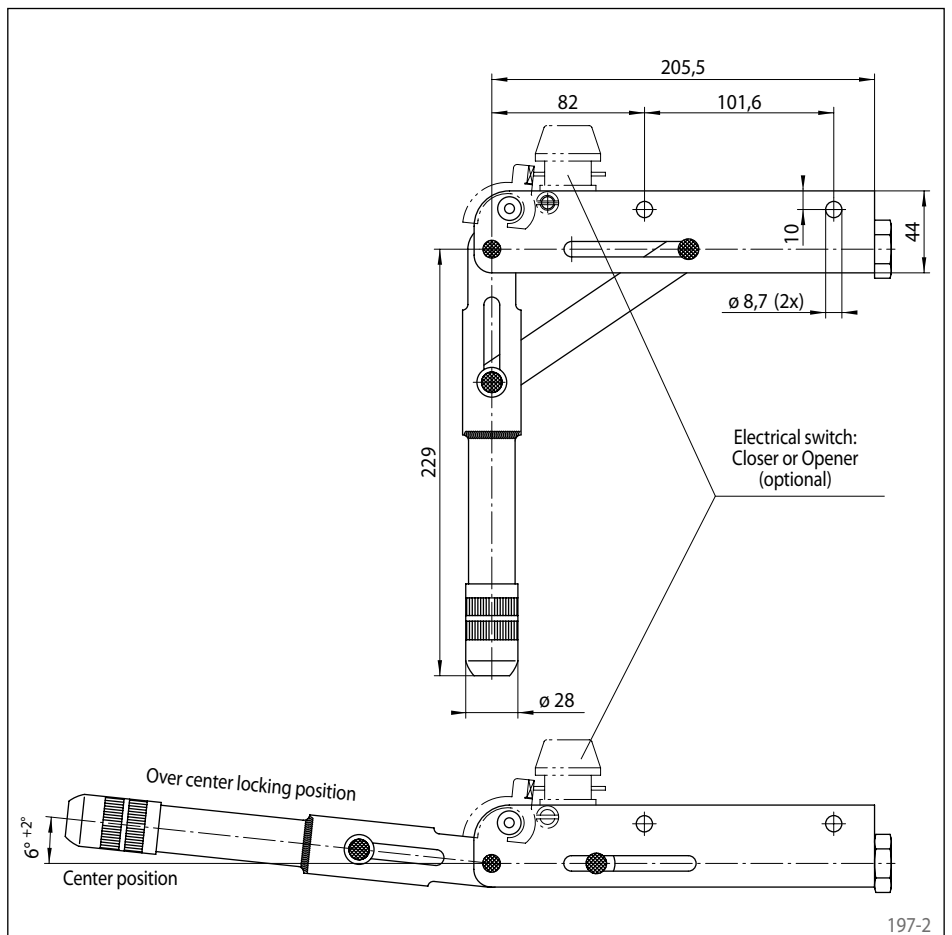

197-2

Control System BCS 600

For controlled braking ...

- with pre-set braking distance
- with pre-set deceleration
- with pre-set braking time

We command
braking actions



Belt conveyors in mining industry



Industrial Application

Brakes are used to stop declining conveyor belts in the mining industry. The brakes should prevent the belt from overshooting or rotating in the reverse direction. The load is not known at the time of braking and consequently the necessary braking torque is unknown.

Brake system requirements

The required braking force transferred onto the belt depends on

- the pre-set braking distance,
- the current load condition,
- the current environmental conditions
- and fluctuations in friction coefficient between pad and disc caused by temperature variations during braking.

For controlled braking ...

- with pre-set braking distance

Elevator car drive for underground mining

Industrial Application

The deceleration of elevator cars has to comply with certain regulations. Oscillations in longitudinal direction should be avoided. The load at the time of braking is unknown and could lead to peak loads in the ropes as well as rope slipping on the drum.

Brake system requirements

The required braking force transferred onto the ropes depends on

- the permissible deceleration,
- load variations,
- the current environmental conditions
- and fluctuations by temperature variations during braking.

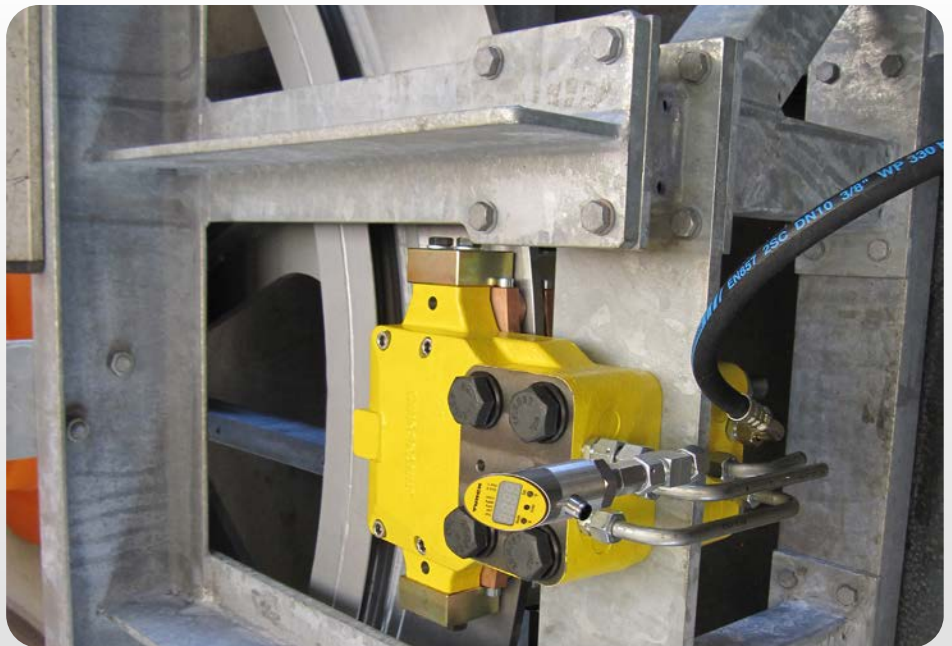

Source: Josef Wiegand GmbH & Co. KG

For controlled braking ...

- with pre-set deceleration

Escalators and moving walkways



Industrial Application

On escalators and moving walkways injuries can occur by stopping too quickly. Regulations prescribe a braking time of 2 - 3 seconds. The number of passengers on the escalator is not known at the time of braking and consequently the necessary braking torque is unknown.

Brake system requirements

The required braking force transferred onto the escalator depends on

- the pre-set braking time,
- the admissible deceleration for passenger transport,
- load variations,
- the current environmental conditions
- and fluctuations by temperature variations during braking.

For controlled braking ...

- with pre-set braking time

Short description

The Control System BCS 600 is a brake control system for hydraulically released or hydraulically activated brakes, based on adjustable hydraulic pressure.

Herewith, demanding braking actions (preset braking time, deceleration and braking distance) are performed reliably. At the same time the BCS 600 accomplishes important safety and monitoring functions. It consists of a control unit and a hydraulic power pack used in conjunction with brakes from the RINGSPANN product range.



Control braking actions

The standstill of the system will be reached independent of general conditions with, consistent braking either by

a pre-set braking distance

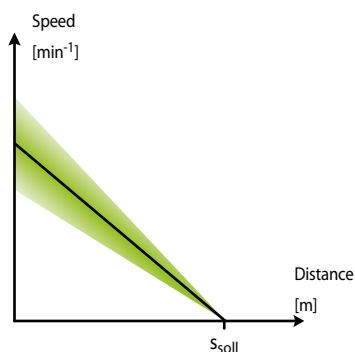

a pre-set deceleration

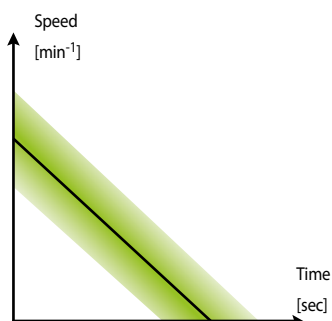

a pre-set braking time

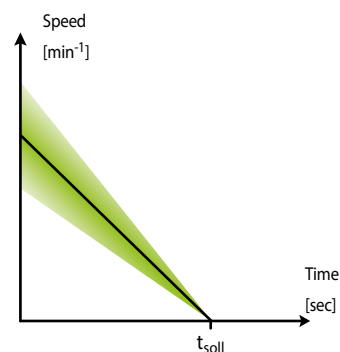

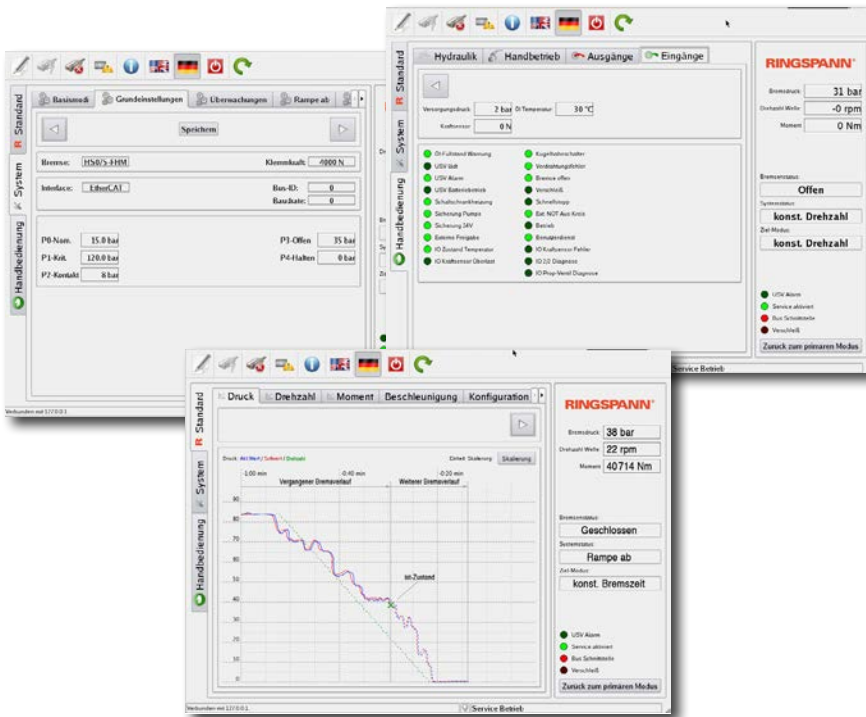

Touchpanel as graphical user interface

Features

- Fast reduction of the gap between disc and brake pad
- Continuous monitoring of rotational speed, hydraulic pressure, oil temperature and rotational direction
- Operation as a stand alone braking system is possible
- Periodically light braking to clean the brake disc
- Graphical visualization of the braking process in real time
- Redundant installation of a second braking system is possible (one supports the other if necessary)
- Retrofit or upgrade of outdated braking systems is possible
- Permanent logging of operating data and system events
- Spring pressure monitoring



Controller IPC

Technical specifications

- Large tank volume
- System pressure: up to 200 bar
- Supply voltage: 110 VAC-50/60 Hz, 230 VAC-50/60 Hz, 400 VAC-50/60 Hz
- Various sensors
- Ambient temperature (standard): -20° C ... +40° C
- Fieldbus interface:

EtherCAT

Options

- Hydraulic Accumulator
- Uninterruptible power supply (UPS)
- Remote maintenance via internet or UMTS
- Touch-Panel for data input and brake process visualization, directly on the Brake Control System
- "Cold Climate Version" (-40° C)
- Monitoring of brake pad wear



Hydraulic powerpack



Hydraulic Power Unit

- For all applications that go beyond the standard functions
- Optimised for the best possible customer solution
- Large system functionality can be realised thanks to modular function blocks
- For one or more hydraulic brakes (also in different brake circuits)
- Customised selection of system elements according to customer requirements

Hydraulic Power Units are customised according to customer requirements. The function in combination with hydraulic brakes is customised in close cooperation with the customer.

202-1



Pneumatic cabinet

Suitable for brakes up to size 035, configuration according to customers demand.

Pneumatic components include:

- Compressor with 5 liter pressure storage for an output range of 0,5 to 6,0 bar
- Filter regulator unit, including condensate separator
- Valve
- Electric power unit 230 V AC

Cabinet size W x H x D - 400 x 500 x 210 mm

Pneumatic Cabinets can be made according to customers demand. Please fill out the "Questionnaire for selecting Brake Calipers" on page 210.

202-2

Clamping Unit KE ... FHK

spring activated – hydraulically released

RINGSPANN®



Features	Code
Clamping Unit	K
Standard	E
Sizes 32, 37, 42, 47, 57, 70, 90, 105, 140 or 160 are available	032 to 160
Spring activated	F
Hydraulically released	H
No wear adjustment	K
For piston rod diameter from 12 mm to 115 mm	012 to 115

Example for ordering

Clamping Unit KE 037 FHK with piston rod diameter 16 mm:

↓
KE 037 FHK - 016

Description

The Clamping Unit KE ... FHK clamps and holds hydraulic cylinder drawbars with a calculated clamping force in both directions of movement.

The clamping force is generated via built-in disc springs. The Clamping Unit is released by hydraulic pressure.

The units are fitted to cylinders and other machine parts with a connecting flange by the customer.

Operation

During the working stroke of the hydraulic cylinder, pressure is exerted onto the Clamping Unit. Through this pressure the disc springs are compressed via the piston. In this position, the clamping discs are free of axial tension and thus allow the piston rod to move freely.

When the pressure on the Clamping Unit is removed, the force of the springs work fully onto the piston and therefore also on to the disc pack. The clamping discs translate the axial spring pressure into a radial force applied to the slotted clamping sleeve that is equal to at least five times the axial pressure. The clamping

sleeve transmits the radial clamping forces to the piston rod, thereby holding the piston rod firmly in place.

Each time the pressure falls - even when this was not planned - the Clamping Unit will respond immediately.

Application

The Clamping Unit secures the piston rod with precision against unintentional axial movements.

For example, on machines with cylinders or linear motors a certain position can be driven in one continuous movement. With the Clamping Unit this position can then be held mechanically with accuracy.

The accuracy of the safety Clamping Unit is independent of the size and the direction of the force on the piston rod up to the maxi-

mum holding force indicated. No movement of the piston rod is required for the holding force to become effective; the clamping force is effective immediately and does not depend on outside forces. If it is necessary to brake the movement of the piston rod, the Clamping Unit would, when pressure falls, produce virtually without delay a constant friction force independent of time. The slowing down of the piston rod is therefore even and protects the decelerated components of the installation.

Features

- For continuous piston rod clamping
- Spring activated, hydraulically released
- Holding forces transmissible in both directions of movement
- No application of force (lifting) to the piston rod required for release

Clamping Unit KE ... FHK

spring activated – hydraulically released

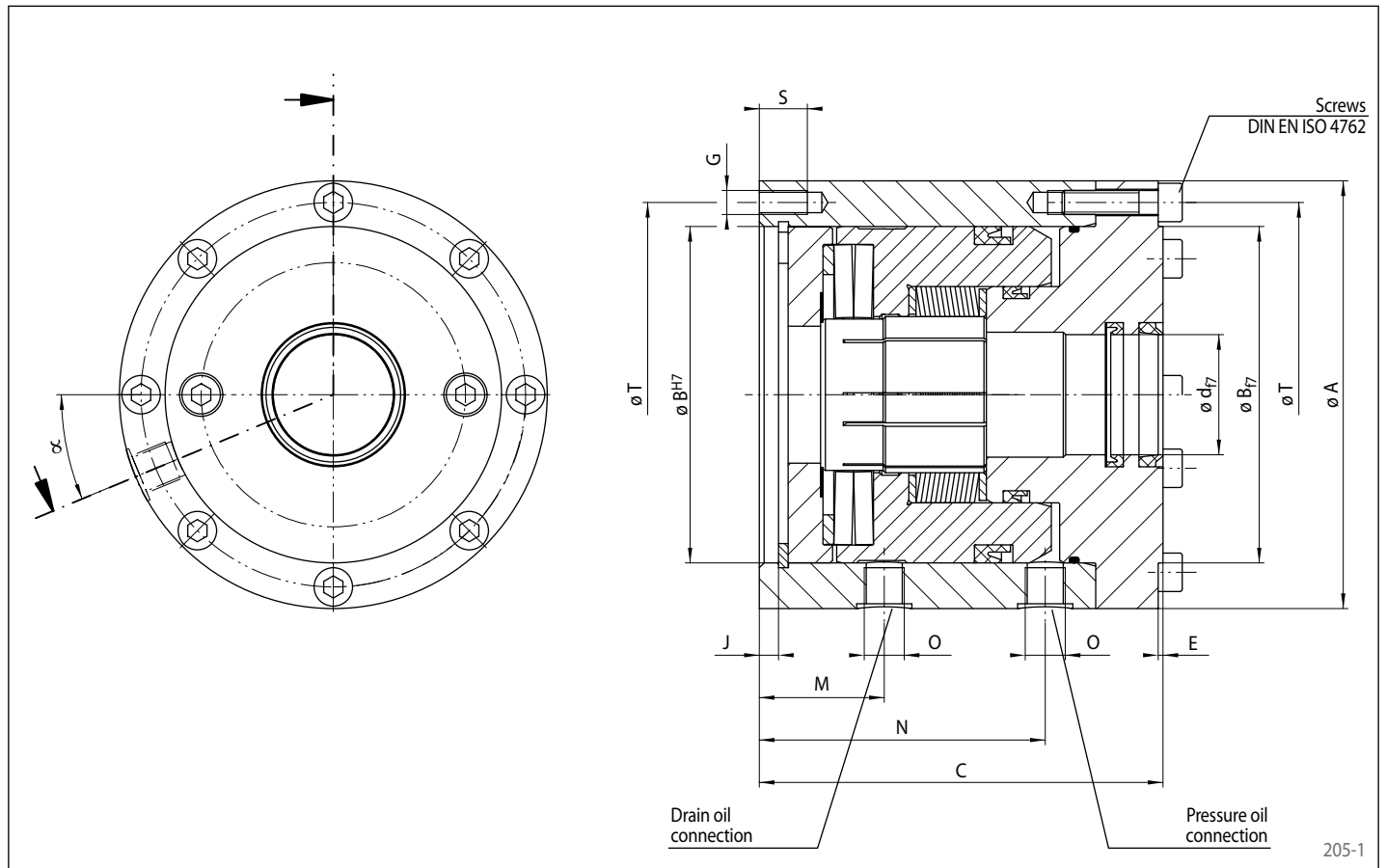

Size	Piston rod- ø d ¹⁾ mm	Holding force F _H ²⁾ N	A mm	B mm	C mm	E mm	G	J mm	M mm	N mm	O	S mm	T mm	X ³⁾	Necess. release press bar	Max. perm. press. bar	Oil vol. per stroke cm ³	α Degree	Weight kg
32	12	2 500	72	48	76	2	M 5	5	26	54	R1/8"	9	60	4	57	120	1	22,5	2,1
37	14 16 18	5 000	85	60	88	2	M 6	6	31	64	R1/8"	11	72	4	68	120	2	22,5	3,4
42	20 22	8 000	100	68	100	2	M 6	6	34	72	R1/8"	11	85	4	82	120	2	22,5	5,3
47	25 28	12 500	110	80	115	2	M 6	7	42	85	R1/8"	15	92	6	84	120	3	22,5	7,3
57	(30) 32 34	19 000	130	95	130	2	M 8	7	48	96	R1/4"	16	112	6	88	120	5	22,5	11,5
70	36 40 45	30 000	150	116	148	3	M 8	4	52	108	R1/4"	16	132	8	102	120	6	22,5	17,2
90	50 (55) 56	48 000	178	140	168	3	M 10	8	52	119	R3/8"	20	160	8	108	160	13	22,5	27,2
105	60 63 70	68 000	210	168	185	3	M 12	10	60	133	R3/8"	22	190	8	122	160	17	22,5	41,2
140	80 (85) 90	120 000	273	220	230	3	M 14	12	75	172	R3/8"	25	250	12	115	160	39	15	86,9
160	100 110 (115)	200 000	330	270	270	5	M 18	16	90	200	R3/8"	38	300	12	110	160	64	15	148,2

¹⁾ Diameter printed in bold to be preferred. Diameter line without () corresponds to DIN 24334.

²⁾ Please note recommendations on page 209.

³⁾ Number of tapped holes G or screws DIN EN ISO 4762 on pitch øT.

Clamping Unit KE ... FPK

spring activated – pneumatically released



Features	Code
Clamping Unit	K
Standard	E
Sizes 40, 50, 63, 80 or 100 are available	040 to 100
Spring activated	F
Pneumatically released	P
No wear adjustment	K

Example for ordering

Clamping Unit KE 040 FPK:

↓
KE 040 FPK

Description

The Clamping Unit KE ... FPK clamps and holds pneumatic cylinder piston rods with a calculated clamping force in both directions of movement.

The clamping force is applied by disc springs. Clamping force is released by pneumatic pressure.

The Clamping Units can be bolted directly to any cylinder of the ISO series or attached to other machine components with a connection flange provided by the customer.

Operation

Pneumatic pressure is applied to the Clamping Unit during the working stroke of the pneumatic cylinder. This pressure is transmitted by the piston via the lever spring to the mount and presses the disc springs together. The lever spring translates the pressure into a clamping force. In this position, the clamping discs are free of axial tension and thus allow the piston rod to move freely.

When the pressure on the Clamping Unit is removed, the force of the springs work fully onto the piston and therefore also on to the disc pack. The clamping discs translate the axial spring pressure into a radial force applied to the slotted clamping sleeve that is equal to at least five times the axial pressure. The clamping sleeve transmits the radial clamping forces to the piston rod, thereby holding the piston rod firmly in place.

Each time the pressure falls - even when this was not planned - the Clamping Unit will respond immediately.

Application

The Clamping Unit secures the piston rod with precision against unintentional axial movements.

For example, on machines with cylinders or linear motors a certain position can be driven in one continuous movement. With the Clamping Unit this position can then be held mechanically with accuracy.

The accuracy of the safety Clamping Unit is independent of the size and the direction of the force on the piston rod up to the maximum holding force indicated. No movement of the piston rod is required for the holding force to become effective; the clamping force is effective immediately and does not depend on outside forces.

Clamping Unit KE ... FPK

RINGSPANN®

spring activated – pneumatically released

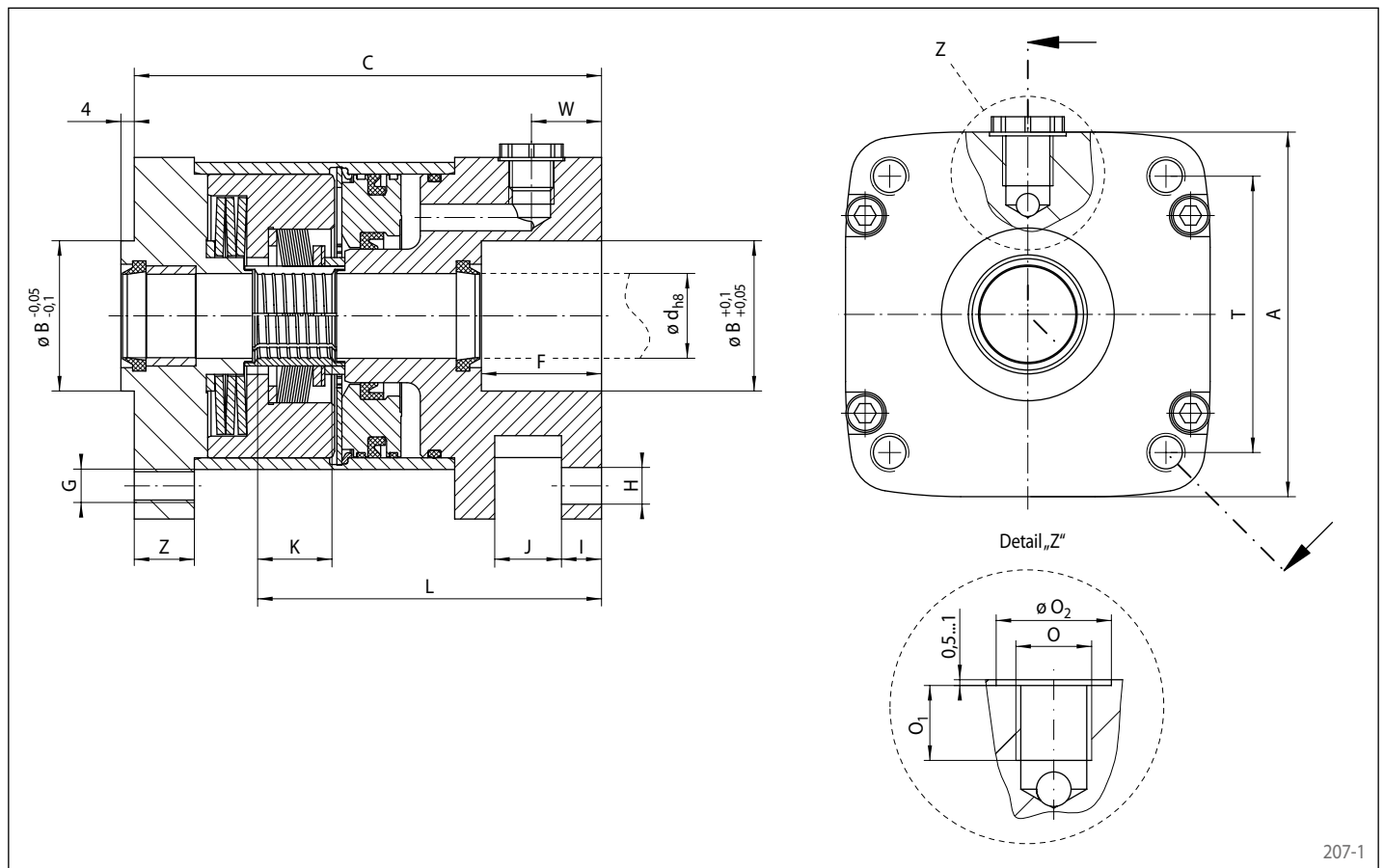

207-1

Size	Piston rod- ø d mm	Holding force F_H ¹⁾ N	A mm	B mm	C mm	F mm	G	H mm	I mm	J mm	O	O ₁ mm	O ₂ mm	T mm	W mm	Z mm	Air volume per activa- tion cm ³	Weight kg
40	16	1 000	70	35	95	24	M6	6,6	6	14	G1/8	10,5	16	38	15,5	13	5,5	1,1
50	20	1 600	75	40	112	30	M8	9	8	16	G1/4	12,5	20	46,5	22,9	13	13,5	1,5
63	20	2 500	95	45	120	30	M8	9	8	16	G1/4	14	20	56,5	15,0	12	27	3,2
80	25	4 000	95	45	140	36	M10	11	12	20	G1/4	14	20	72	21,0	18	27	3,5
100	25	6 300	120	55	150	40	M10	11	12	20	G1/4	14	20	89	21,0	19	59	5,8

¹⁾ Please note recommendations on page 209.

Features

- For continuous piston rod clamping
- Spring activated, pneumatically released
- Connection dimensions compatible with pneumatic cylinders according to ISO
- Direct mounting on pneumatic cylinders
- Holding forces transmissible in both directions of movement
- No application of force (lifting) to the piston rod required for release

Release pressure

The release pressure of the spring activated pneumatically released Clamping Unit KE ... FPK is min. 5 bar and max. 8 bar.

Brake Calipers

Selection of Brake Calipers

When selecting RINGSPANN Brakes, two criteria need to be considered:

- Is the selected combination of brake caliper/ brake disc capable of braking the torque requirement of the application?
- Can the brake disc transfer the frictional heat without damage to adjacent parts?

Calculation of the braking torque

Braking of rotating masses

The necessary braking torque results from the mass inertia moment relative to the brake shaft J_{red} . When braking to a stop $n_2 = 0$.

$$M_B = M_R = \frac{J_{red}}{t_B} \cdot \frac{n_1 - n_2}{9,55}$$

$$M_R = \frac{J_{red}}{t_B} \cdot \frac{n_1 - n_2}{9,55}$$

$$M_V = \frac{m}{t_B} \cdot \frac{n_1 - n_2}{38,25} \cdot \left(\frac{D_L}{i}\right)^2 \cdot \eta$$

Braking of rotating masses with additional motor braking

If an additional braking torque M_{Bf} is available, e.g. from an electric motor with dynamic braking, then the formula for the necessary braking torque is:

$$M_B = M_R - M_{Bf} = \frac{J_{red}}{t_B} \cdot \frac{n_1 - n_2}{9,55} - M_{Bf}$$

Braking of chassis

The required braking torque for a deceleration is made up of the load torque M_L originating from the net weight G of the installation, the braking torque for the deceleration of the rotating masses M_R and the braking torque for decelerating the linear-moving masses M_V (referred to the braking shaft).

$$M_B = M_L + M_R + M_V$$

$$M_{Lmax} = (G \sin \gamma + F_W - F_F) \cdot \frac{D_L \cdot \eta}{2 \cdot i}$$

After completing this calculation, check whether the braking torque M_B can be transmitted via the chassis wheel friction.

$$M_B < \mu_R \cdot m \cdot g \cdot \frac{D_L}{2}$$

Controlled braking for winding processes

The required braking torque varies between the value M_{Bi} with minimum winding diameter d_i and M_{Ba} with maximum winding diameter d_a .

$$M_{Bi} = \frac{F_S \cdot d_i}{2}$$

$$M_{Ba} = \frac{F_S \cdot d_a}{2}$$

Braking torques and parking torques

The braking torques given in this catalogue are dynamic braking torques. They only apply:

- When the brake linings have been run in,
- original RINGSPANN brake discs, or brake discs made from the recommended material are used and
- friction linings have been selected for the particular application.

If the disc brakes are used as holding brakes then the given brake torques are only applicable as parking torques if the above conditions are met. If running-in is not possible or if the running-in process is omitted, the braking torques given will not be achieved; torque reductions of up to 50% are possible. If static parking torques are required but without running-in, then special friction linings are needed. For such applications, please refer the matter to us for advice.

Continuous Slipping

Winding operations may require a variety of processes regarding tension of the wound material and winding speed. We therefore recommend an initial rough calculation of M_{Ba} and M_{Bi} .

Please send us the completed questionnaire on page 210 for a more accurate evaluation.

$$P_{Bi} = \frac{M_{Bi} \cdot n_i}{9\,550} \quad \text{or} \quad P_{Bi} = \frac{F_S \cdot d_i \cdot n_i}{19\,100}$$

$$P_{Ba} = \frac{M_{Ba} \cdot n_a}{9\,550} \quad \text{or} \quad P_{Ba} = \frac{F_S \cdot d_a \cdot n_a}{19\,100}$$

Formula symbols

d_i	[m]	Smallest diameter of roller	F_F	[N]	Traction resistance on the chassis wheel	J_{red}	[kg m ²]	Reduced inertia moment
d_a	[m]	Largest diameter of roller	F_H	[N]	Holding force	i	-	Gear ratio between chassis wheel and brake shaft
D	[mm]	Diameter of brake disc	F_{Nenn}	[N]	Nominal holding force	m	[kg]	Mass of complete chassis
D_L	[m]	Chassis wheel diameter	F_S	[N]	Tension on the winding material	M_B	[Nm]	Required braking torque
F	[N]	Holding force taking account of hydraulic oil and clamping duration	F_W	[N]	Wind reaction force on chassis	M_{Bf}	[Nm]	Braking torque of the motor
F_a	[N]	Maximum axial force including dynamic forces occurring during operation	G	[N]	Total weight of chassis	M_{Ba}	[Nm]	Braking torque for roller diameter d_a

Clamping Units

Note for design and installation

Holding Force F_H

If the system is driven with hydraulic fluid, it is likely that after a certain operating time the piston rod will have a film of oil on it from the installation. Therefore the holding force is affected by the hydraulic oil being used.

The following applies to hydraulic oils H and HL, and to unalloyed oils:

$$F_{Nenn} = F_H$$

For hydraulic oils HLP and HL-XP this applies:

$$F_{Nenn} = F_H \cdot 0,8$$

The nominal holding force thus calculated is reached when the clamping time t between removal of the release pressure and the application of the load does not fall below a minimum value of 5 seconds. This applies to oils up to VG 100 with a minimum temperature of 20° C at the piston rod.

If the clamping time t is shorter, then the holding force F transmissible depending on viscosity should be taken from the diagram.

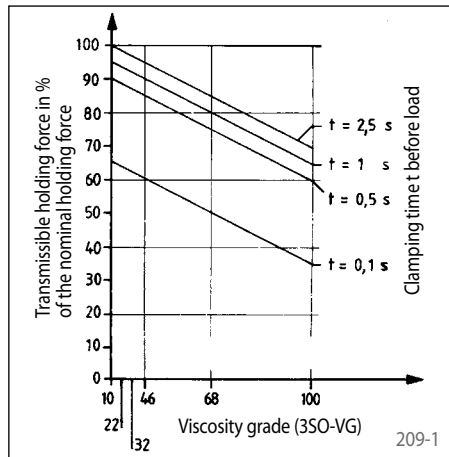

Holding force depending on oil viscosity and clamping period prior to load (temperature at the piston rod 20 °C)

If the hydraulic oil has a large amount of EP additives (eg V 6710, DH 46) the nominal holding force can fall below 80% of the table value. In such a case it would be necessary to carry out field tests. **Solid lubricants like MoS₂, Graphite or Teflon should never be allowed near the clamping position.**

Safety factor

$$\text{Safety factor } S = \frac{F}{F_a}$$

Positioning accuracy

Clamping is effected without any axial movement between rod and clamping unit.

Under axial force F_H an axial shift of up to 0,1 mm may occur in hydraulically released Clamping Units and up to 0,05 mm in pneumatically released Clamping Units between the rod and the clamping unit. This shift is reversed when pressure is released.

The rod to be clamped

The rod to be clamped should be made of material with a tensile strength of at least 600 N/mm² (e. g. C 45). It must be hard chromium plated or surface hardened and ground. The diameter must be designed with fit f7 in hydraulically released Clamping Units and with fit h8 in pneumatically released Clamping Units and a peak-to-valley height of $R_t = 5 \mu\text{m}$. With normal use the maximum pressure at the point of clamping between the piston rod and the clamping unit is 150 N/mm².

Sealing and Centering

Hydraulically released Clamping Units

are equipped with a rod gasket and stripper on the cover side.

A seal against waste oil should be provided by the customer on the side of the machine or cylinder where the clamping connection is to be located.

Pneumatically released Clamping Units

are equipped with strippers on both sides.

In order to ensure a lasting and trouble free operation and to avoid damage to the rod to be clamped, the exact concentricity of the bar towards the machine centering must be kept. (Max. circular runout 0,04 mm.)

Release to facilitate Mounting

To insert the rod, hydraulic or pneumatic pressure is applied on the clamping unit.

Special Types

If special types with a higher positioning accuracy, higher holding forces or lower release pressures are required, please let us have your enquiry together with the completed questionnaire on the page 211.

M_{Bi} [Nm]	Braking torque for roller diameter d_i	n_1 [min^{-1}]	Speed before braking	P_{Bi} [kW]	Brake power with winding diameter d_i
M_L [Nm]	Load torque	n_2 [min^{-1}]	Speed after braking	t_B [s]	Braking time
M_{Lmax} [Nm]	Maximum load torque	n_i [min^{-1}]	Speed at d_i	γ [°]	Angle of inclination
M_R [Nm]	Deceleration torque of rotating masses	n_a [min^{-1}]	Speed at d_a	η -	Gear efficiency - if known, calculation with $\eta=0,85$ is advised
M_V [Nm]	Deceleration torque of linear moving masses	P_B [kW]	Brake power generated by application, average with one braking cycle	μ_R	Roller friction value on the chassis wheel
		P_{Ba} [kW]	Brake power with winding diameter d_a		

Please photocopy or use the technical enquiry form on our website (www.ringspann.com)!

Company: Name:	Phone: E-mail: Date:				
1. Application <input type="checkbox"/> Stopping brake <input type="checkbox"/> Control brake <input type="checkbox"/> Holding brake					
2. Function <table style="width:100%; border: none;"> <tr> <td style="width:33%; border: none;"> Activation: <input type="checkbox"/> spring <input type="checkbox"/> pneumatically <input type="checkbox"/> electromagnetically <input type="checkbox"/> hydraulically <input type="checkbox"/> manually with threaded spindle <input type="checkbox"/> manually with Pull Cable </td> <td style="width:33%; border: none;"> Release: <input type="checkbox"/> pneumatically <input type="checkbox"/> hydraulically <input type="checkbox"/> electromagnetically <input type="checkbox"/> electrohydraulically <input type="checkbox"/> manually with Pull Cable <input type="checkbox"/> spring <input type="checkbox"/> spring <input type="checkbox"/> spring <input type="checkbox"/> non-releasing <input type="checkbox"/> manually with threaded spindle <input type="checkbox"/> manually with Pull Cable </td> <td style="width:33%; border: none;"> Existing pressure: _____ bar _____ bar _____ bar _____ bar </td> </tr> </table>		Activation: <input type="checkbox"/> spring <input type="checkbox"/> pneumatically <input type="checkbox"/> electromagnetically <input type="checkbox"/> hydraulically <input type="checkbox"/> manually with threaded spindle <input type="checkbox"/> manually with Pull Cable	Release: <input type="checkbox"/> pneumatically <input type="checkbox"/> hydraulically <input type="checkbox"/> electromagnetically <input type="checkbox"/> electrohydraulically <input type="checkbox"/> manually with Pull Cable <input type="checkbox"/> spring <input type="checkbox"/> spring <input type="checkbox"/> spring <input type="checkbox"/> non-releasing <input type="checkbox"/> manually with threaded spindle <input type="checkbox"/> manually with Pull Cable	Existing pressure: _____ bar _____ bar _____ bar _____ bar	
Activation: <input type="checkbox"/> spring <input type="checkbox"/> pneumatically <input type="checkbox"/> electromagnetically <input type="checkbox"/> hydraulically <input type="checkbox"/> manually with threaded spindle <input type="checkbox"/> manually with Pull Cable	Release: <input type="checkbox"/> pneumatically <input type="checkbox"/> hydraulically <input type="checkbox"/> electromagnetically <input type="checkbox"/> electrohydraulically <input type="checkbox"/> manually with Pull Cable <input type="checkbox"/> spring <input type="checkbox"/> spring <input type="checkbox"/> spring <input type="checkbox"/> non-releasing <input type="checkbox"/> manually with threaded spindle <input type="checkbox"/> manually with Pull Cable	Existing pressure: _____ bar _____ bar _____ bar _____ bar			
3. Friction block wear <table style="width:100%; border: none;"> <tr> <td style="width:50%; border: none;"> Adjustment of brake <input type="checkbox"/> Automatic <input type="checkbox"/> Manual </td> <td style="width:50%; border: none;"> Control required? <input type="checkbox"/> Yes <input type="checkbox"/> No </td> </tr> </table>		Adjustment of brake <input type="checkbox"/> Automatic <input type="checkbox"/> Manual	Control required? <input type="checkbox"/> Yes <input type="checkbox"/> No		
Adjustment of brake <input type="checkbox"/> Automatic <input type="checkbox"/> Manual	Control required? <input type="checkbox"/> Yes <input type="checkbox"/> No				
4. The following safety rules must be observed					
5. Type of machine					
6. Part to be braked					
7. Technical Data <table style="width:100%; border: none;"> <tr> <td style="width:33%; border: none;"> Stopping brake: Required braking torque _____ Nm Required braking time _____ s Reduced mass inertia moment to be braked _____ kgm² Weight of linear masses to be braked _____ kg Transmission up to brake shaft i _____ Driving speed v _____ m/s Chassis wheel diameter D_R _____ mm Angle of inclination γ _____ ° Speed before braking n_1 _____ min⁻¹ Speed after braking n_2 _____ min⁻¹ Idling speed n _____ min⁻¹ Braking cycles per hour z _____ h⁻¹ </td> <td style="width:33%; border: none;"> Control brake: Tension on winding material F_S _____ N Speed of material v _____ m/s Max. winding diameter d_a _____ m Min. winding diameter d_i _____ m Length of feed reels L _____ m Material to be wound _____ _____ Duration of operation t _____ s </td> <td style="width:33%; border: none;"> Holding brake: Holding torque _____ Nm Please note the information given under braking torques and parking torques on page 208. </td> </tr> </table>		Stopping brake: Required braking torque _____ Nm Required braking time _____ s Reduced mass inertia moment to be braked _____ kgm ² Weight of linear masses to be braked _____ kg Transmission up to brake shaft i _____ Driving speed v _____ m/s Chassis wheel diameter D_R _____ mm Angle of inclination γ _____ ° Speed before braking n_1 _____ min ⁻¹ Speed after braking n_2 _____ min ⁻¹ Idling speed n _____ min ⁻¹ Braking cycles per hour z _____ h ⁻¹	Control brake: Tension on winding material F_S _____ N Speed of material v _____ m/s Max. winding diameter d_a _____ m Min. winding diameter d_i _____ m Length of feed reels L _____ m Material to be wound _____ _____ Duration of operation t _____ s	Holding brake: Holding torque _____ Nm Please note the information given under braking torques and parking torques on page 208.	
Stopping brake: Required braking torque _____ Nm Required braking time _____ s Reduced mass inertia moment to be braked _____ kgm ² Weight of linear masses to be braked _____ kg Transmission up to brake shaft i _____ Driving speed v _____ m/s Chassis wheel diameter D_R _____ mm Angle of inclination γ _____ ° Speed before braking n_1 _____ min ⁻¹ Speed after braking n_2 _____ min ⁻¹ Idling speed n _____ min ⁻¹ Braking cycles per hour z _____ h ⁻¹	Control brake: Tension on winding material F_S _____ N Speed of material v _____ m/s Max. winding diameter d_a _____ m Min. winding diameter d_i _____ m Length of feed reels L _____ m Material to be wound _____ _____ Duration of operation t _____ s	Holding brake: Holding torque _____ Nm Please note the information given under braking torques and parking torques on page 208.			
8. Mounting of brake to the machine <table style="width:100%; border: none;"> <tr> <td style="width:50%; border: none;"> <input type="checkbox"/> Parallel to brake disc </td> <td style="width:50%; border: none;"> <input type="checkbox"/> Right-angled to brake disc </td> </tr> </table>		<input type="checkbox"/> Parallel to brake disc 	<input type="checkbox"/> Right-angled to brake disc 		
<input type="checkbox"/> Parallel to brake disc 	<input type="checkbox"/> Right-angled to brake disc 				
9. Brake disc <table style="width:100%; border: none;"> <tr> <td style="width:25%; border: none;"> Required disc diameter _____ mm Max. permissible disc diameter _____ mm </td> <td style="width:25%; border: none;"> <input type="checkbox"/> Form F, without bore or roughbored <input type="checkbox"/> Form F, with bore d_F^{H7} _____ mm </td> <td style="width:25%; border: none;"> <input type="checkbox"/> Form B, without bore or roughbored <input type="checkbox"/> Form B, with bore d_B^{H7} with keyway _____ mm </td> <td style="width:25%; border: none;"> <input type="checkbox"/> Form S with Shrink Disc RLK 608 for clamping diameter d_S _____ mm </td> </tr> </table>		Required disc diameter _____ mm Max. permissible disc diameter _____ mm	<input type="checkbox"/> Form F, without bore or roughbored <input type="checkbox"/> Form F, with bore d_F^{H7} _____ mm	<input type="checkbox"/> Form B, without bore or roughbored <input type="checkbox"/> Form B, with bore d_B^{H7} with keyway _____ mm	<input type="checkbox"/> Form S with Shrink Disc RLK 608 for clamping diameter d_S _____ mm
Required disc diameter _____ mm Max. permissible disc diameter _____ mm	<input type="checkbox"/> Form F, without bore or roughbored <input type="checkbox"/> Form F, with bore d_F^{H7} _____ mm	<input type="checkbox"/> Form B, without bore or roughbored <input type="checkbox"/> Form B, with bore d_B^{H7} with keyway _____ mm	<input type="checkbox"/> Form S with Shrink Disc RLK 608 for clamping diameter d_S _____ mm		
10. Installation conditions Ambient temperature from _____ °C to _____ °C Other information (e. g. special ambient conditions) _____					
11. Estimated requirement _____ Piece (one-off) _____ Piece/month _____ Piece/year					

RINGSPANN®

Your benefit is our motivation

↪ Scan me for more information



www. **RINGSPANN®**.com