

Precision Clamping Fixtures

Precision Clamping Chucks • Precision Clamping Mandrels • Clamping Clutches

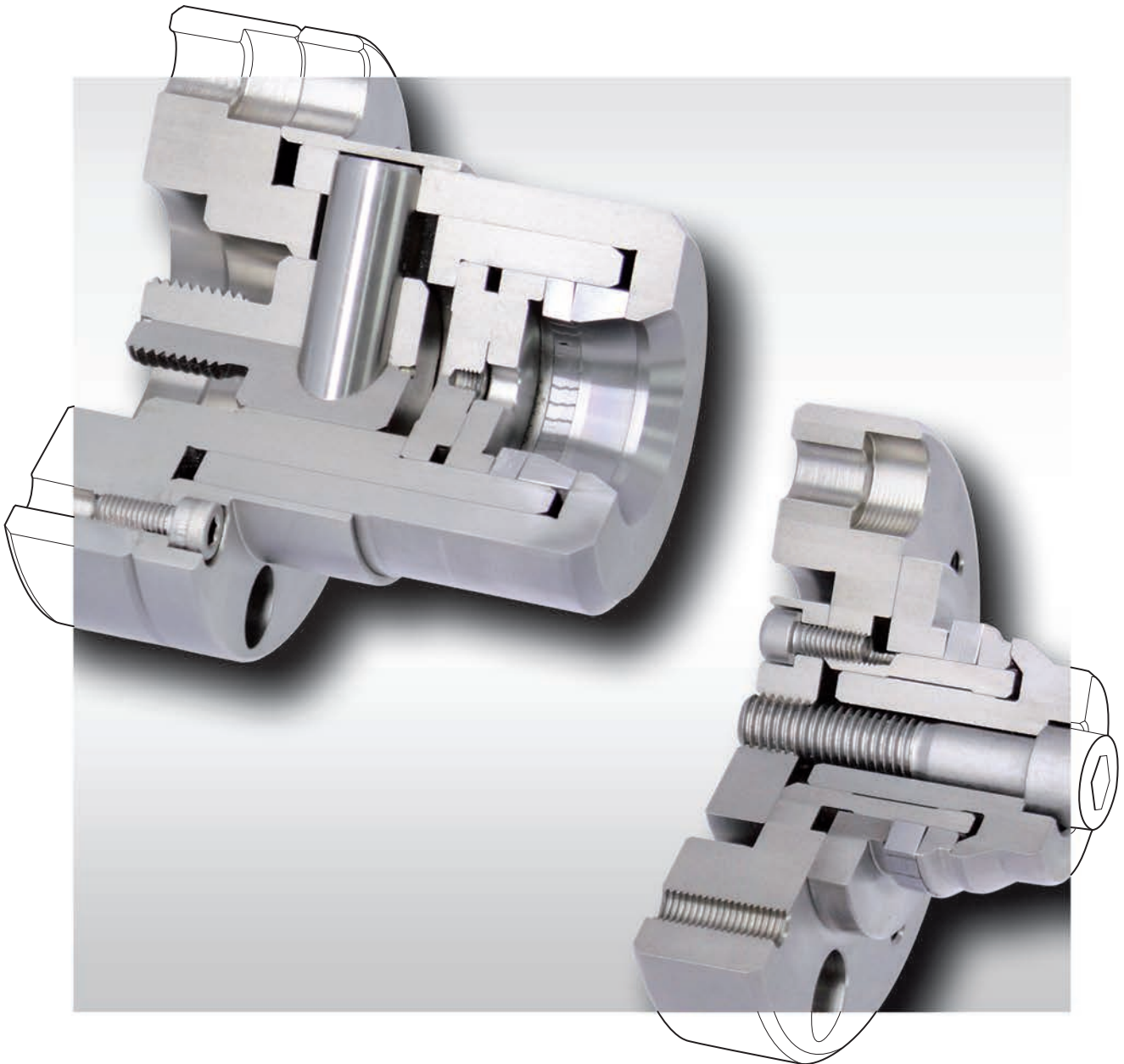

Edition 2020/2021



Precision Clamping Fixtures technology introduction	Page
The RINGSPANN Clamping Fixture Range	3
The RINGSPANN Idea	4
Advantages of RINGSPANN Clamping Fixtures	5
Overview of RINGSPANN Clamping Fixtures	6
Precision Clamping Chucks	Page
Bonded Disc Pack Flange Chucks LAFF	8
Clamping Elements Bonded Disc Packs LAF and LHF and components for setup of Bonded Disc Pack Flange Chucks	10
Taper Collet Flange Chucks BKFF	14
Clamping Elements Taper Collets BKF for setup Taper Collet Flange Chucks	16
Taper Sleeve Flange Chucks HKFF	18
Clamping Elements Taper Sleeves HKF and components for setup Taper Sleeve Flange Chucks	20
Flat Element Flange Chucks KFFF	22
Clamping Elements Flat Elements KFF and components for setup Flat Element Flange Chucks	24
Precision Clamping Mandrels	Page
Bonded Disc Pack Flange Mandrels LBDF	26
Clamping Elements Bonded Disc Packs LBD and LID and components for setup Bonded Disc Pack Flange Mandrels	28
Taper Collet Flange Mandrels BKDF	34
Clamping Elements Taper Collets BKD, BVD and BAD and components for setup Taper Collet Flange Mandrels	36
Taper Sleeve Flange Mandrels HKDF	42
Clamping Elements Taper Sleeves HKD and components for setup Taper Sleeve Flange Mandrels	44
Flat Element Flange Mandrels KFDF	46
Clamping Elements Flat Elements KFD and components for setup Flat Element Flange Mandrels	48
Taper Collet Centre Mandrels BKDI	50
Clamping Elements Taper Collets BMD for setup Taper Collet Centre Mandrel	52
Expanding Sleeve Mandrels HDDS	54
Clamping Clutches	Page
Clamping Clutches SKDZ for printing cylinders in printing presses	56
Accessories for Precision Clamping Fixtures	Page
for machine connections in accordance to DIN 55026 Form A	
Intermediate Flanges Z Type A, B, C and P	58
for machine connections of balancing machines	
Intermediate Flanges Z Type D	61
Spring Force Actuator FUSR	62
Precision Clamping technology details	Page
Application examples	64
Technical points	72
Questionnaire	78



**Bonded Disc Pack
Flange Chucks
LAFF**

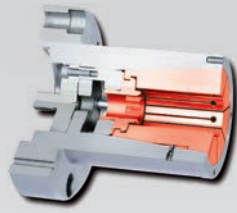

**Taper Collet
Flange Chucks
BKFF**

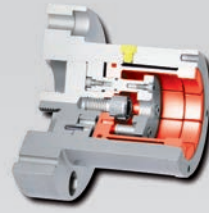

**Taper Sleeve
Flange Chucks
HKFF**



**Flat Element
Flange Chucks
KFFF**

Precision Clamping Chucks



**Bonded Disc Pack
Flange Mandrels
LBDF**

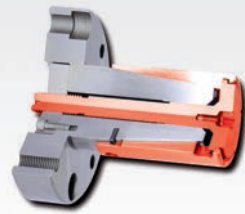

**Taper Collet
Flange Mandrels
BKDF**

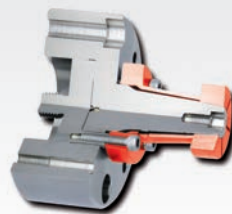

**Taper Sleeve
Flange Mandrels
HKDF**



**Flat Element
Flange Mandrels
KDFD**

Precision Clamping Mandrels



**Short Element
Clamping Mandrels
BKDI**

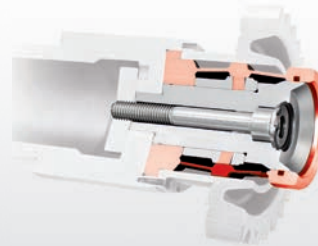

**Expanding Sleeve
Mandrels
HDDS**

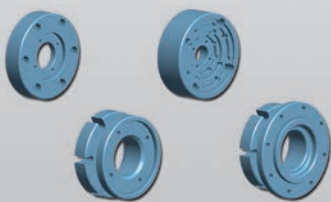

**Intermediate Flanges Z
Type A, B, C and P**

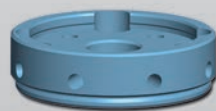

**Intermediate Flanges Z
Type D**



**Spring Force Actuator
FUSR**

Accessories
for Precision Clamping Fixtures

RINGSPANN has been developing and manufacturing Precision Clamping Fixtures for work-holding applications for over 75 years. Over the past decades we have realized thousands of applications and numerous technically sophisticated solutions.

RINGSPANN specialized in clamping and centering on cylindrical internal and external surfaces. Typical components include automobile, gear and aircraft components.

We have developed the RINGSPANN system on the basis of the RINGSPANN Clamping Disc, which encompasses

- **Complete Clamping Fixtures**, ready-to-use and
- **Clamping Elements and components** for customer assembled Clamping Fixtures.

The RINGSPANN system offers the right solution for each clamping application and guarantees maximum clamping precision without the need for complicated alignment. This enables customers to achieve difficult objectives, such as clamping in short lengths or clamping thin-walled components that are susceptible to deformation.

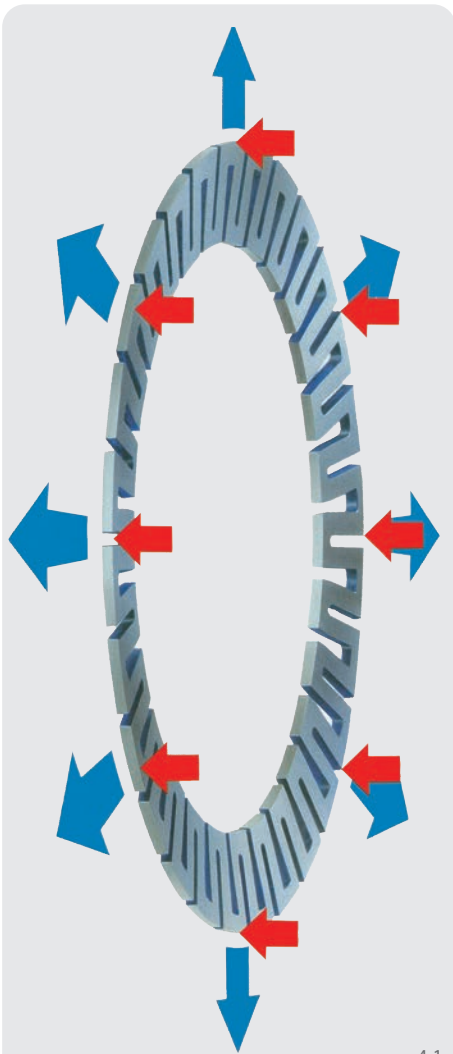

4-1

The basis of the RINGSPANN system is the RINGSPANN Clamping Disc, a flat-tapered ring made of special hardened spring steel. The characteristic slotting provides for especially high elasticity.

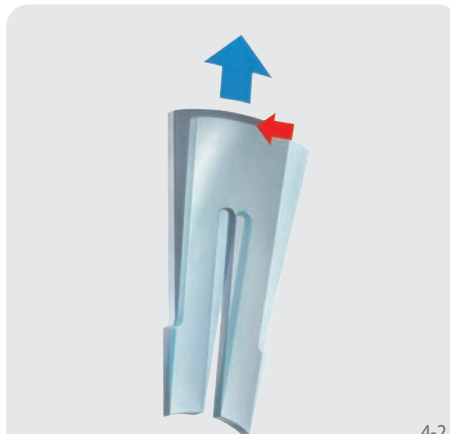

4-2

The axial actuating force causes an elastic change in the taper angle and thus alters the diameter of the Clamping Disc. If its inside diameter is supported by a mandrel, the outside diameter expands. If the outside diameter of the Clamping Disc is supported, the inside diameter decreases.

Especially advantageous is the so-called RINGSPANN effect. The initiated actuating force is transposed friction-free into a radial force that is 5 to 10 times higher, which is then used to clamp the component.



4-3

The actuating force simultaneously induces a tipping movement of the Clamping Disc. This movement is used to press the component against a longitudinal backstop during clamping.

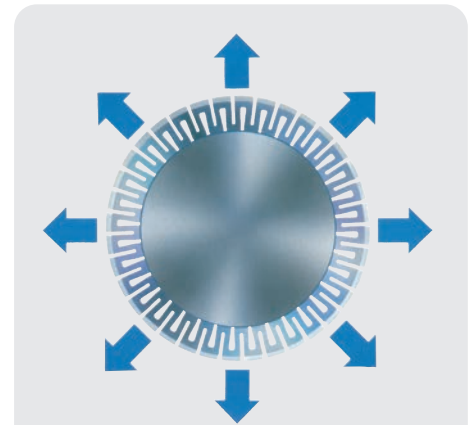

4-4

Mounted on a mandrel, the Clamping Disc engages the entire inside circumference of the component bore. The radial forces produce a frictional connection between the Clamping Disc and the component.

The uniform application of force to the entire circumference of the component guarantees maximum clamping precision and permits the transmission of higher torques, even in contact with elastic components that are susceptible to deformation.

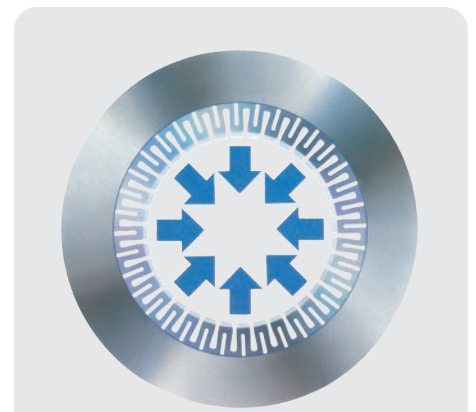

4-5

Similarly, the cylindrical outside surfaces of the component are clamped by a Clamping Disc seated in a chuck.

High true running accuracy

True running accuracy of $\leq 0,01$ mm is attainable.

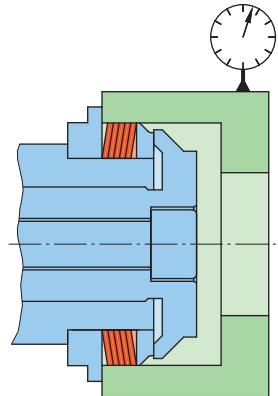

5-1

Short clamping lengths

The RINGSPANN system permits short clamping lengths with high torque transmission.

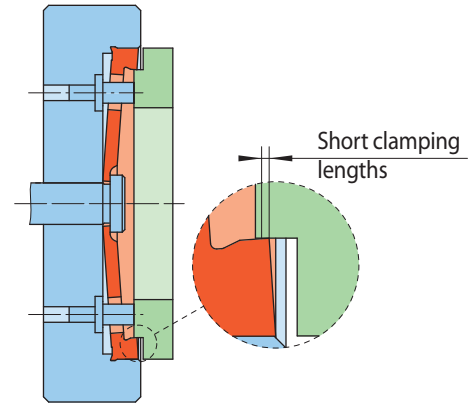

5-2

Short clamping fixture length

Clamping Fixtures based on the RINGSPANN system ensure minimum spindle overhang and thus high spindle rigidity and precision.

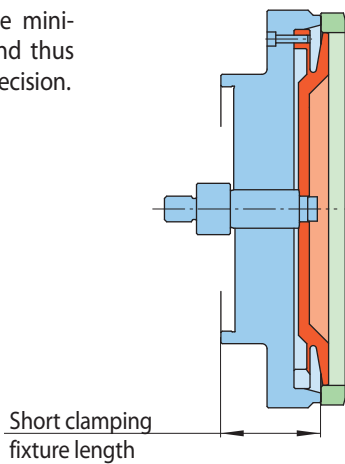

5-3

Extended insertion depths

The RINGSPANN system supports extended insertion depths with high torque transmission.

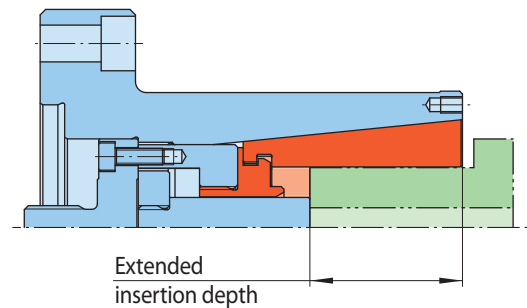

5-4

No deformation

The thinner-walled a workpiece is, the more sensitive to deformation it becomes. A three-jaw chuck can no longer be used economically with such workpieces, since the clamping forces must be reduced to a level that ensures it doesn't cause any impermissible deformation. This inevitably leads to a reduction of the cutting data and thus an increase in the impact duration. Using RINGSPANN Clamping Fixtures, workpieces are gripped over their entire circumference. It is thus pos-

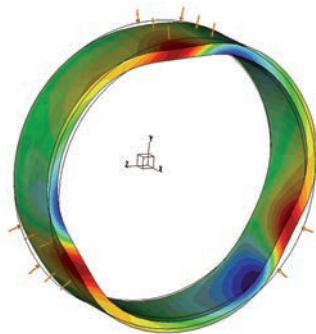





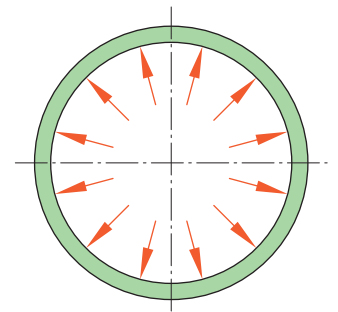



5-5

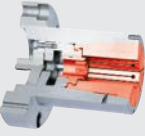

sible to clamp with much higher forces, which ensures that the economic efficiency of production is maintained thanks to high cutting performances and short impact duration.



5-6

Overview of RINGSPANN Clamping Fixtures

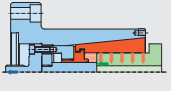
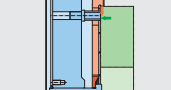
		Complete Clamping Fixtures	Clamping diameter			True running accuracy			Permissible component tolerance					
			small < 50 mm	medium 50 - 200 mm	large 200 - 1600 mm	≤ 0,020 mm	≤ 0,010 mm	≤ 0,005 mm	up to IT 7	up to IT 9	up to IT 10	up to IT 11	up to IT 13	up to IT 15
Precision Clamping Chucks	Bonded Disc Pack Flange Chucks		from 7 mm to 170 mm			●	●		●	●		●		
	Taper Collet Flange Chucks		from 7,2 mm to 73,6 mm			●	●		●	●		●	●	●
	Taper Sleeve Flange Chucks		from 15 mm to 206 mm			●	●		●	●		●	●	
	Flat Element Flange Chucks		from 30 mm to 520 mm			●	●		●	●		●		
Precision Clamping Mandrels	Bonded Disc Pack Flange Mandrels		from 18 mm to 200 mm			●	●		●	●	●	●		
	Taper Collet Flange Mandrels		from 11,9 mm to 132 mm			●	●		●	●	●	●	●	●
	Taper Sleeve Flange Mandrels		from 9 mm to 275 mm			●	●		●	●	●	●	●	
	Flat Element Flange Mandrels		from 41 mm to 560 mm			●	●		●	●	●	●		
	Taper Collet Centre Mandrels		from 11,9 mm to 132 mm			●	●		●	●	●	●	●	●
	Expanding Sleeve Mandrels		from 25 mm to 82,5 mm			●	●	●	●	●	●			

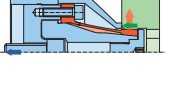
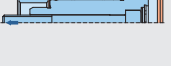
Clamping fixture length		Clamping length		Insertion depth			Pull-back action	Possible component wall thickness		Hand clamping optional possible	Clamping principle	Page
short	long	short	long	very short	short	long		thin	solid			
	●	●			●		●	●			8 - 13	
	●	●	●	●	●	●	●	●	●		14 - 17	
	●	●		●	●	●	●		●		18 - 21	
●		●		●			●		●		22 - 25	
	●	●			●		●	●	●		26 - 33	
	●	●	●		●	●	●	●	●		34 - 41	
	●	●		●	●		●		●*		42 - 45	
●		●		●			●		●		46 - 49	
	●	●	●		●	●	●	●	●		50 - 53	
	●	●			●	●	●	●	●		54 - 55	

*Not available in all sizes

Key:  Axial actuating force  Radial clamping force  Axial pull-back force

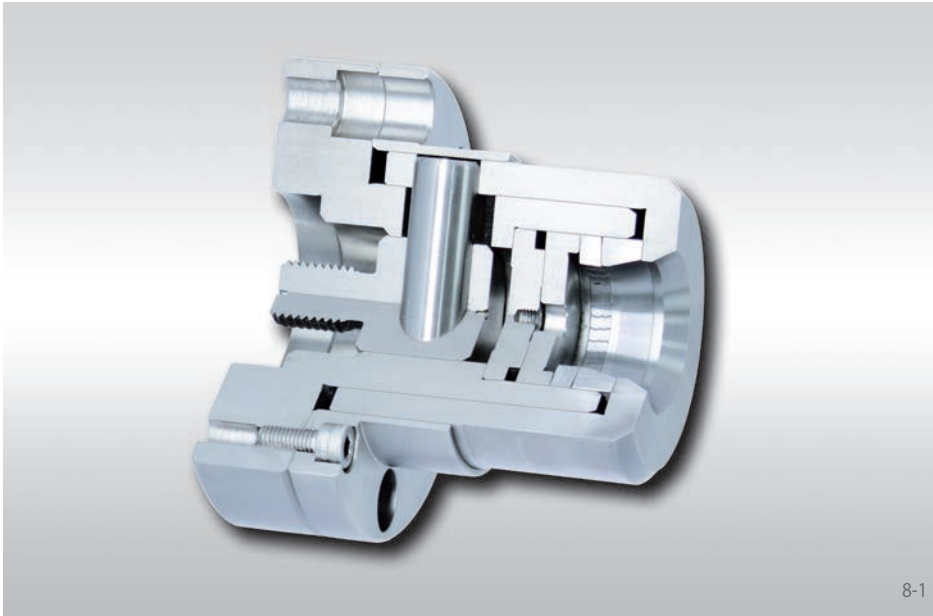

8-1

Features

- For clamping diameters from 7 mm to 80 mm
- High true running accuracy $\leq 0,01$ mm
- Permissible component tolerance up to IT11
- Short or long clamping length possible
- Pull-back against shoulder ring
- For thin-walled or solid components
- Impervious to ingress of foreign objects due to the rubberized slots in the Bonded Disc Pack

Configuration

The Bonded Disc Pack Flange Chuck consists of a seating body, a cap bush, draw and cross bolts, base and shoulder rings, a Bonded Disc Pack, a thrust ring and a draw bush. The Bonded Disc Pack Flange Chuck is attached to the machine with the seating body. The Clamping Fixture is actuated via the draw bolt, which is connected to the machine power actuating unit. Depending on the required transmitted torque, Bonded Disc Packs of different widths may be installed. The required installation situations for the base and shoulder rings are shown in Fig. 9-2.

Intermediate Flanges and Spring Force Actuators are shown starting on page 58.

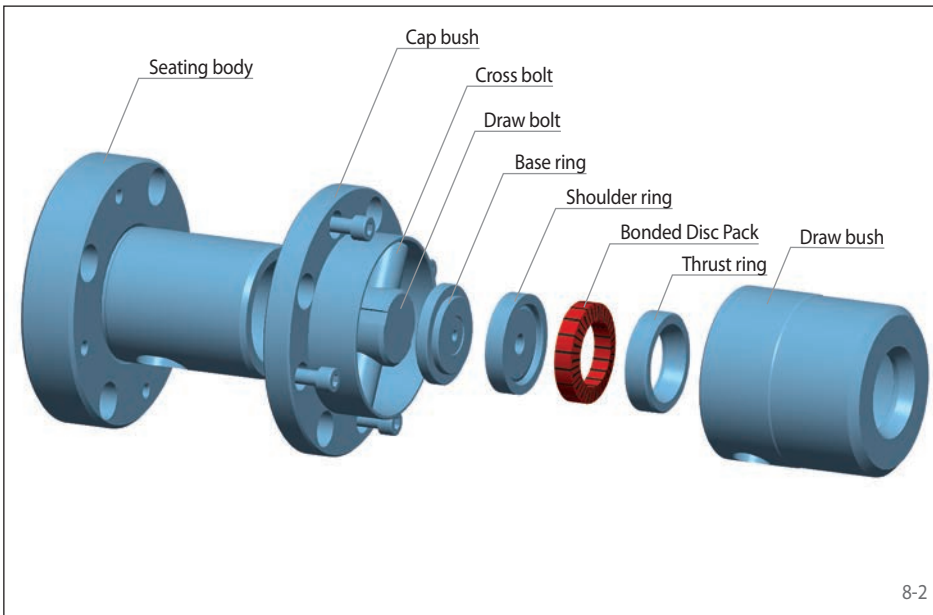

8-2

Clamping principle

The Bonded Disc Pack sits pre-loaded in the seating diameter of the seating body. To actuate clamping, the Bonded Disc Pack is raised to an upright position by axial actuating force. The component is centred, pressed flush against the shoulder ring and aligned. The tipping movement of the Bonded Disc Pack converts the axial actuating force into a radial clamping force that is up to ten times higher.

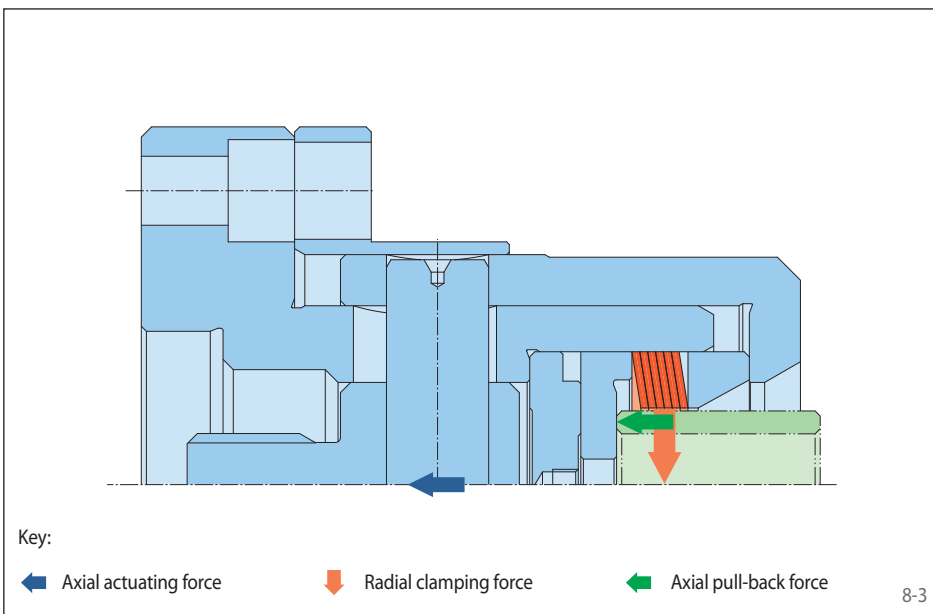

8-3

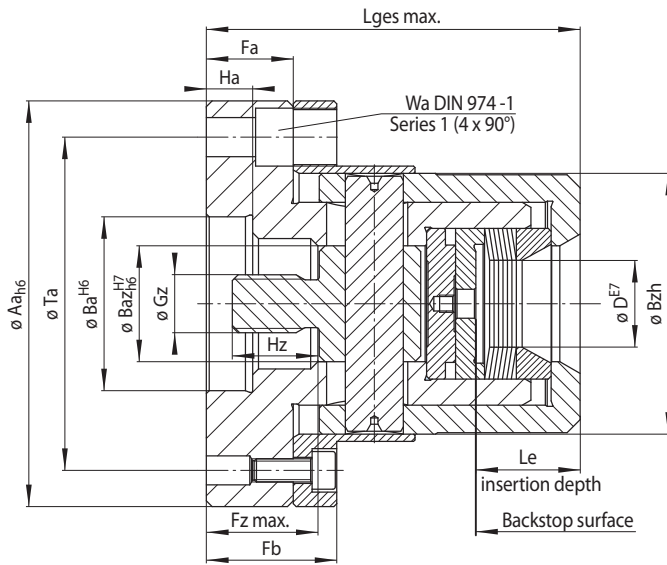

Installation situations

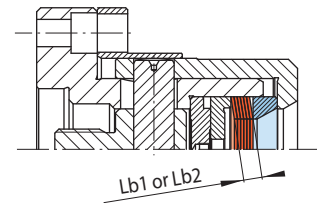

Bonded disc pack widths Lb1 and Lb2

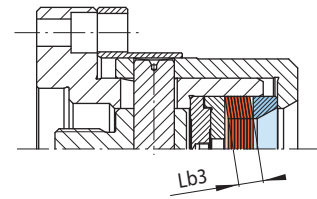

Bonded disc pack width Lb3

9-1

9-2

Size	Achievable clamping diameter D* mm	Maximum diameter change** Δ D mm	Bonded disc pack width Lb1			Bonded disc pack width Lb2			Bonded disc pack width Lb3			Aa	Ba	Baz	Bzh	Fa	Fb	Fz max.	Gz	Ha	Hz	Le	Lges max.	Ta	Wa
			Lb1 mm	M Nm	Fm kN	Lb2 mm	M Nm	Fm kN	Lb3 mm	M Nm	Fm kN	mm	mm	mm	mm	mm	mm	mm	mm	mm	mm	mm	mm	mm	mm
LAFF 22	7 - 10	0,10	4	2,3	1,4	6	3,5	2,1	8	4,6	2,8	90	50	17	40	30	45	33,9	M 10	14	15	20	93,3	70	8
	10 - 15	0,10	4	5,6	2,4	6	8,4	3,5	8	10	4,7	90	50	17	40	30	45	33,9	M 10	14	15	20	93,3	70	8
LAFF 32	10 - 15	0,15	6	8,0	3,6	9	10	5,3	12	10	7,1	90	50	25	55	30	45	38,5	M 12	16	20	20	115	70	8
	15 - 20	0,15	6	20	6,0	9	30	8,9	12	40	11,9	90	50	25	55	30	45	38,5	M 12	16	20	20	115	70	8
LAFF 42	20 - 25	0,15	6	30	8,0	9	50	12,0	12	60	16,0	120	60	35	70	30	45	36	M 16	16	25	32	123	95	10
	25 - 30	0,15	6	60	10,8	9	90	16,2	12	120	21,6	120	60	35	70	30	45	36	M 16	16	25	32	123	95	10
LAFF 52	30 - 35	0,15	6	80	12,4	9	120	18,6	12	160	24,8	140	60	40	90	30	45	39	M 20	16	30	36	129	115	12
	35 - 40	0,15	6	120	15,6	9	180	23,4	12	240	31,2	140	60	40	90	30	45	39	M 20	16	30	36	129	115	12
LAFF 62	40 - 45	0,15	6	160	17,6	9	240	26,4	12	320	35,2	160	90	45	100	35	50	45	M 24	21	35	37	142	135	12
	45 - 50	0,15	6	200	20,8	9	310	31,2	12	410	41,6	160	90	45	100	35	50	45	M 24	21	35	37	142	135	12
LAFF 80	50 - 55	0,25	6	250	22,2	10	420	37,0	16	670	59,2	200	125	55	125	35	50	46,7	M 24	21	35	43,7	164,5	175	12
	55 - 60	0,25	6	300	25,2	10	510	42,0	16	810	67,2	200	125	55	125	35	50	46,7	M 24	21	35	43,7	164,5	175	12
LAFF 90	60 - 65	0,25	6	370	27,0	10	620	45,0	16	990	72,0	200	125	65	140	35	50	41,7	M 24	21	35	44,7	175,5	175	12
	65 - 70	0,25	6	430	30,0	10	730	50,0	16	1160	80,0	200	125	65	140	35	50	41,7	M 24	21	35	44,7	175,5	175	12
LAFF 100	70 - 75	0,25	6	510	31,8	10	850	53,0	16	1360	84,8	225	125	70	160	35	50	41,7	M 24	21	35	44,7	175,5	200	12
	75 - 80	0,25	6	580	35,4	10	980	59,0	16	1560	94,4	225	125	70	160	35	50	41,7	M 24	21	35	44,7	175,5	200	12

* Clamping diameter from > up to ≤ adjustable to two places after the decimal point

** of the clamping diameter of the Clamping Element.

Key

- D = Achievable clamping diameter
- Δ D = Maximum diameter change of the clamping diameter of the Clamping Element
- Lb = Bonded disc pack width
- M = Max. transmissible torque
- Fm = Required actuating force for component clamping with pull-back action for max. transmissible torque

Example for ordering

Please indicate the size of the Clamping Fixture and the clamping diameter of your component, including component tolerance, and the desired bonded disc pack width in your order:

Size: LAFF 42
 Clamping diameter: 21,47 mm
 Component tolerance: h6
 Bonded disc pack width: 9 mm
 ➔ LAFF 42-21,47h6-9

Clamping Elements Bonded Disc Packs LAF

for setup of Bonded Disc Pack Flange Chucks LAFF to different clamping diameters within a given size and high true running accuracy

Installation situations

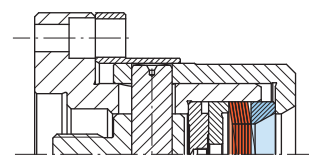
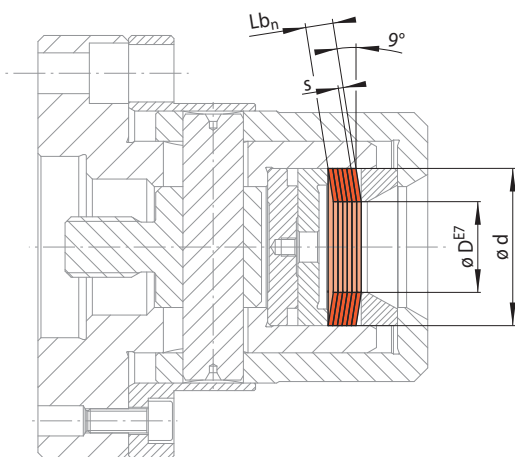

Bonded disc pack widths Lb1 and Lb2

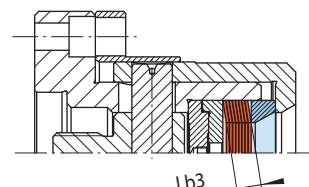

Bonded disc pack width Lb3

10-1

10-2

Size LAF ... ¹⁾	Clamping Discs LAF							Bonded Disc Packs LAF														
	d	D*	ΔD	s	M ₁	Fm ₁	Fo ₁	Art.-No.	Bonded disc pack width Lb1				Bonded disc pack width Lb2				Bonded disc pack width Lb3					
									Lb1	M _n	Fm _n	Fo _n	Art.-No.	Lb2	M _n	Fm _n	Fo _n	Art.-No.	Lb3	M _n	Fm _n	Fo _n
mm	mm	mm	mm	Nm	N	N	1002-	mm	Nm	N	N	3022-	mm	Nm	N	N	3022-	mm	Nm	N	N	3022-
22	7 - 10	0,10	0,50	0,3	170	110	022001	4	2,3	1400	900	022001	6	3,5	2100	1400	022002	8	4,6	2800	1800	022003
	10 - 15	0,10	0,50	0,7	290	190	022004	4	5,6	2400	1600	022004	6	8,4	3500	2400	022005	8	10	4700	3100	022006
32	10 - 15	0,15	0,75	1,0	440	300	032001	6	8,0	3600	2400	032001	9	10	5300	3600	032002	12	10	7100	4800	032003
	15 - 20	0,15	0,75	2,5	740	510	032004	6	20	6000	4100	032004	9	30	8900	6200	032005	12	40	11900	8200	032006
42	20 - 25	0,15	0,75	4,7	1000	680	042001	6	30	8000	5500	042001	9	50	12000	8300	042002	12	60	16000	10900	042003
	25 - 30	0,15	0,75	7,5	1350	930	042004	6	60	10800	7500	042004	9	90	16200	11300	042005	12	120	21600	14900	042006
52	30 - 35	0,15	0,75	10	1550	1050	052001	6	80	12400	8400	052001	9	120	18600	12600	052002	12	160	24800	16800	052003
	35 - 40	0,15	0,75	15	1950	1350	052004	6	120	15600	10800	052004	9	180	23400	16200	052005	12	240	31200	21600	052006
62	40 - 45	0,15	0,75	20	2200	1450	062001	6	160	17600	11600	062001	9	240	26400	17400	062002	12	320	35200	23200	062003
	45 - 50	0,15	0,75	26	2600	1800	062004	6	200	20800	14400	062004	9	310	31200	21600	062005	12	410	41600	28800	062006
80	50 - 55	0,25	1,00	42	3700	2450	080001	6	250	22200	14700	080001	10	420	37000	24500	080002	16	670	59200	39200	080003
	55 - 60	0,25	1,00	51	4200	2900	080004	6	300	25200	17400	080004	10	510	42000	29000	080005	16	810	67200	46400	080006
90	60 - 65	0,25	1,00	62	4500	3000	090001	6	370	27000	18000	090001	10	620	45000	30000	090002	16	990	72000	48000	090003
	65 - 70	0,25	1,00	73	5000	3500	090004	6	430	30000	21000	090004	10	730	50000	35000	090005	16	1160	80000	56000	090006
100	70 - 75	0,25	1,00	85	5300	3600	100001	6	510	31800	21600	100001	10	850	53000	36000	100002	16	1360	84800	57600	100003
	75 - 80	0,25	1,00	98	5900	4100	100004	6	580	35400	24600	100004	10	980	59000	41000	100005	16	1560	94400	65600	100006
110	80 - 85	0,25	1,00	110	6100	4100	110001	6	660	36600	24600	110001	10	1100	61000	41000	110002	16	1760	97600	65600	110003
	85 - 90	0,25	1,00	130	6800	4700	110004	6	780	40800	28200	110004	10	1300	68000	47000	110005	16	2080	108800	75200	110006

¹⁾ Intermediate sizes on request

* Clamping diameter from > up to ≤ adjustable to two places after the decimal point

for setup of Bonded Disc Pack Flange Chucks LAFF to different clamping diameters within a given size and high true running accuracy

Installation situations

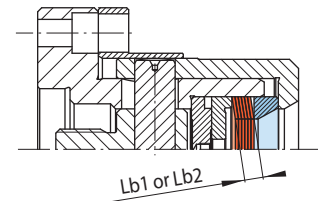
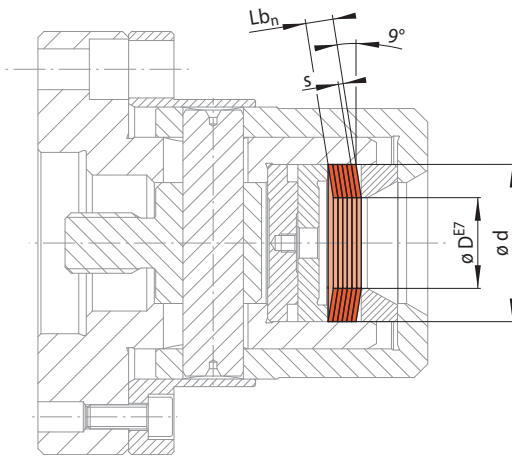

Bonded disc pack widths Lb1 and Lb2

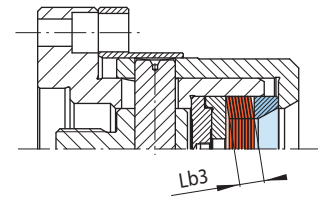

Bonded disc pack width Lb3

11-1

11-2

Size LAF ... ¹⁾	Clamping Discs LAF							Bonded Disc Packs LAF														
	d	D*	ΔD	s	M ₁	F _{m1}	F _{o1}	Art.-No.	Bonded disc pack width Lb1				Bonded disc pack width Lb2				Bonded disc pack width Lb3					
									Lb1	M _n	F _{m_n}	F _{o_n}	Art.-No.	Lb2	M _n	F _{m_n}	F _{o_n}	Art.-No.	Lb3	M _n	F _{m_n}	F _{o_n}
mm	mm	mm	mm	Nm	N	N	1002-	mm	Nm	N	N	3022-	mm	Nm	N	N	3022-	mm	Nm	N	N	3022-
120	90 - 95	0,25	1,00	140	7000	4700	120001	6	840	42000	28200	120001	10	1400	70000	47000	120002	16	2240	112000	75200	120003
	95 - 100	0,25	1,00	160	7700	5300	120004	6	960	46200	31800	120004	10	1600	77000	53000	120005	16	2560	123200	84800	120006
140	100 - 105	0,35	1,25	190	8400	5700	140009	6,3	950	42400	28800	140010	10	1520	67400	45800	140011	20	3040	134800	91600	140012
	105 - 110	0,35	1,25	210	8900	6200	140011	6,3	1050	44900	31300	140004	10	1680	71300	49700	140005	20	3360	142600	99400	140006
	110 - 115	0,35	1,25	230	9800	6800	140013	6,3	1150	49400	34300	140004	10	1840	78500	54500	140005	20	3680	157000	109000	140006
160	115 - 120	0,35	1,25	260	9800	6600	160007	6,3	1310	49400	33300	160001	10	2080	78500	52900	160002	20	4160	157000	105800	160003
	120 - 125	0,35	1,25	290	10500	7200	160009	6,3	1460	53000	36300	160001	10	2320	84200	57700	160002	20	4640	168400	115400	160003
	125 - 130	0,35	1,25	310	11000	7600	160011	6,3	1560	55500	38400	160004	10	2480	88100	61000	160005	20	4960	176200	122000	160006
	130 - 135	0,35	1,25	340	11900	8400	160013	6,3	1710	60000	42400	160004	10	2720	95300	67400	160005	20	5440	190600	134800	160006
180	135 - 140	0,35	1,25	370	11800	7900	180007	6,3	1860	59500	39900	180001	10	2960	94500	63400	180002	20	5920	189000	126800	180003
	140 - 145	0,35	1,25	400	12500	8500	180009	6,3	2010	63000	42900	180001	10	3200	100000	68100	180002	20	6400	200000	136200	180003
	145 - 150	0,35	1,25	420	13100	9000	180011	6,3	2110	66100	45400	180004	10	3360	105000	72100	180005	20	6720	210000	144200	180006
	150 - 155	0,35	1,25	460	14000	9800	180013	6,3	2310	70600	49400	180004	10	3680	112100	78500	180005	20	7360	224200	157000	180006
190	155 - 160	0,35	1,25	500	14300	9800	190011	6,3	2520	72100	49400	190001	10	4000	114500	78500	190002	20	8000	229000	157000	190003
	160 - 165	0,35	1,25	530	15200	10600	190013	6,3	2670	76700	53500	190001	10	4240	121800	85000	190002	20	8480	243600	170000	190003
200	165 - 170	0,35	1,25	560	15200	10400	200008	6,3	2820	76700	52500	200010	10	4480	121800	83400	200011	20	8960	243600	166800	200012

¹⁾ Intermediate sizes on request

* Clamping diameter from > up to ≤ adjustable to two places after the decimal point

Key

- d = Seating diameter
- D = Achievable clamping diameter
- ΔD = Maximum diameter change of the clamping diameter of the Clamping Element
- s = Clamping disc thickness
- n = Number of Clamping Discs (max. 16)
- Lb_n = s • n = Bonded disc pack width

- M_n = M₁ • n = Max. transmissible torque
- F_{m_n} = F_{m1} • n = Required actuating force for component clamping with pull-back action for max. transmissible torque
- F_{o_n} = F_{o1} • n = Required actuating force for component clamping without pull-back action for max. transmissible torque

Example for ordering

Please indicate the size of the Clamping Element, the clamping diameter of your component, including component tolerance, and the desired bonded disc pack width in your order:

Size: LAF 42
 Clamping diameter: 21,47 mm
 Component tolerance: h6
 Bonded disc pack width: 12 mm

➔ LAF 42-21,47h6-12

for setup of Bonded Disc Pack Flange Chucks LHFF to different clamping diameters within a given size with large component tolerances, high true running accuracy and high clearance

Key

- d = Seating diameter
- D = Achievable clamping diameter
- ΔD = Maximum diameter change of the clamping diameter of the Clamping Element
- s = Clamping disc thickness
- n = Number of Clamping Discs (max. 16)
- $Lb_n = s \cdot n$
= Bonded disc pack width
- $M_n = M_1 \cdot n$
= Max. transmissible torque
- $Fm_n = Fm_1 \cdot n$
= Required actuating force for component clamping with pull-back action
- $Fo_n = Fo_1 \cdot n$
= Required actuating force for component clamping without pull-back action

Installation situations

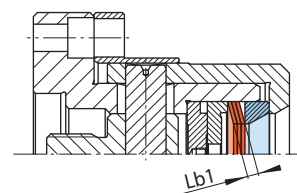

Bonded disc pack widths Lb1

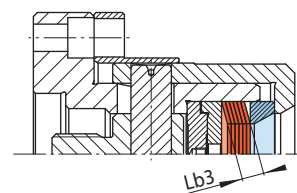

Bonded disc pack width Lb3

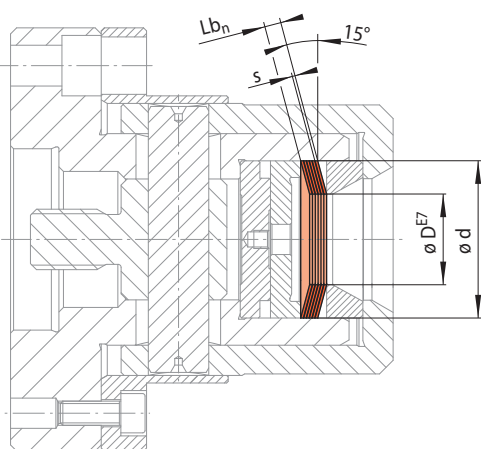

12-1

12-2

Size LHF ...	Clamping Discs LHF							Bonded Disc Packs LHF										
	d	D*	ΔD	s	M_1	Fm_1	Fo_1	Art.-No.	Bonded disc pack width Lb1					Bonded disc pack width Lb3				
									Lb1	M_n	Fm_n	Fo_n	Art.-No.	Lb3	M_n	Fm_n	Fo_n	Art.-No.
mm	mm	mm	mm	Nm	N	N	1004-	mm	Nm	N	N	3024-	mm	Nm	N	N	3024-	
32	11 - 15	0,7	0,75	1,0	540	435	032002	6	8	4320	3480	032003	12	16	8640	6960	032004	
37	15 - 20	0,7	0,75	2,5	950	765	037002	6	20	7600	6120	037003	12	40	15200	12240	037004	
42	20 - 25	0,7	0,75	4,5	1350	1080	042002	6	36	10800	8640	042003	12	72	21600	17280	042004	
47	25 - 30	0,7	0,75	7,0	1650	1300	047002	6	56	13200	10400	047003	12	112	26400	20800	047004	
52	30 - 35	0,7	0,75	10	1950	1550	052002	6	80	15600	12400	052003	12	160	31200	24800	052004	
57	35 - 40	0,7	0,75	14	2350	1900	057002	6	112	18800	15200	057003	12	224	37600	30400	057004	
62	40 - 45	0,7	0,75	19	2800	2250	062002	6	152	22400	18000	062004	12	304	44800	36000	062005	
70	45 - 50	0,9	1,0	33	4450	3600	070002	8	264	35600	28800	070004	16	528	71200	57600	070005	
80	50 - 55	0,9	1,0	41	4800	3850	080003	8	328	38400	30800	080008	16	656	76800	61600	080009	
	55 - 60	0,9	1,0	51	5550	4500	080004	8	408	44400	36000	080010	16	816	88800	72000	080011	
90	60 - 65	0,9	1,0	60	5900	4750	090003	8	480	47200	38000	090006	16	960	94400	76000	090007	
	65 - 70	0,9	1,0	72	6650	5400	090004	8	576	53200	43200	090008	16	1152	106400	86400	090009	
100	70 - 75	0,9	1,0	84	7050	5650	100003	8	672	56400	45200	100009	16	1344	112800	90400	100010	
	75 - 80	0,9	1,0	97	7750	6300	100004	8	776	62000	50400	100011	16	1552	124000	100800	100012	
110	80 - 85	0,9	1,0	112	8150	6600	110003	8	896	65200	52800	110005	16	1792	130400	105600	110006	
	85 - 90	0,9	1,0	127	8900	7200	110004	8	1016	71200	57600	110007	16	2032	142400	115200	110008	
120	90 - 100	0,9	1,0	129	8350	6700	120002	8	1032	66800	53600	120003	16	2064	133600	107200	120004	
140	100 - 115	1,0	1,25	185	10800	8700	140002	10	1480	86400	69600	140005	20	2960	172800	139200	140006	
150	115 - 125	1,0	1,25	255	13300	10800	150002	10	2040	106400	86400	150004	20	4080	212800	172800	150005	
160	125 - 135	1,0	1,25	305	14500	11700	160002	10	2440	116000	93600	160003	20	4880	232000	187200	160004	
170	135 - 145	1,0	1,25	365	16000	13000	170002	10	2920	128000	104000	170005	20	5840	256000	208000	170006	
180	145 - 165	1,0	1,25	420	17200	14000	180002	10	3360	137600	112000	180003	20	6720	275200	224000	180004	
190	155 - 165	1,0	1,25	470	18100	14700	190002	10	3760	144800	117600	190005	20	7520	289600	235200	190006	

* Clamping diameter from > up to ≤ adjustable to two places after the decimal point

The Bonded Disc Packs LHF have a larger taper angle than the Bonded Disc Packs LAF. This makes it possible to clamp larger component tolerances up to IT14 securely. The achievable true running accuracy is ≤ 0,015 mm. Bonded Disc Packs LHF can limited be used in Bonded Disc Pack Flange Chucks. We request that you contact us.

Example for ordering

Please indicate the size of the Clamping Element, the clamping diameter of your component, including component tolerance, and the desired bonded disc pack width in your order:

Size: LHF 42
 Clamping diameter: 21,47 mm
 Component tolerance: h6
 Bonded disc pack width: 12 mm

➔ LHF 42-21,47h6-12

Thrust ring

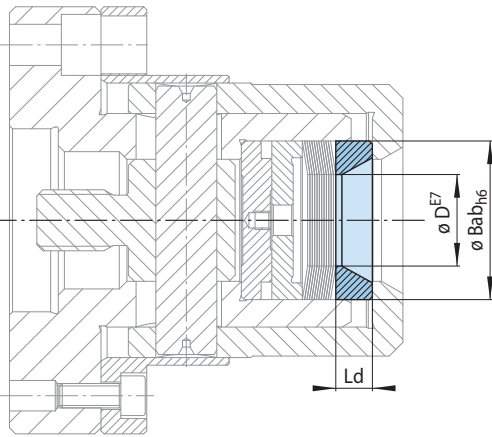

13-1

for size	Bab mm	D* mm	Ld mm	Art.-No. 2178-
LAFF 22	22	7 - 15	5,5	022900
LAFF 32	32	10 - 20	9	032900
LAFF 42	42	20 - 30	10	042900
LAFF 52	52	30 - 40	12	052900
LAFF 62	62	40 - 50	12	062900
LAFF 80	80	50 - 60	13	080900
LAFF 90	90	60 - 70	13	090900
LAFF 100	100	70 - 80	13	100900

* $\varnothing D_{E7}$ for thrust ring and disc / bonded disc pack has to manufactured in same nominal dimensions.

Variants for arrangement of Bonded Disc Packs LAF or LHF

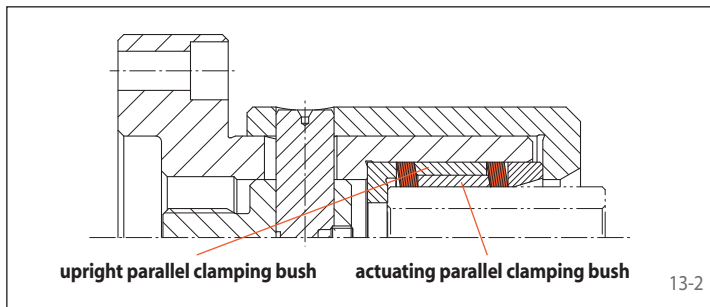

13-2

Parallel Bonded Disc Pack Flange Chucks

to transmit high operating torque and for clamping in long bores with tolerance $\leq IT7$. Precondition:

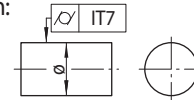

Functional principle:

The upright parallel clamping bush remains stationary and retains the Bonded Disc Pack in position, the actuating bush transmits the actuating force by axial movement.

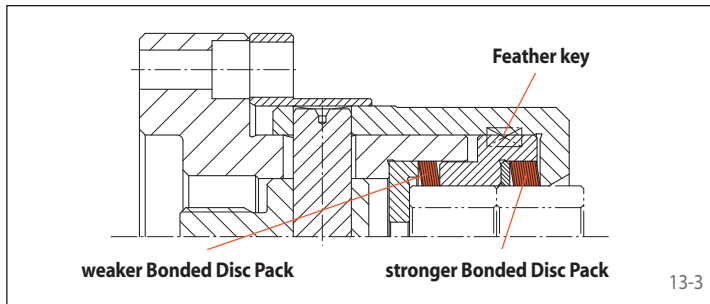

13-3

Series Bonded Disc Pack Flange Chuck

for clamping two identical components.

Functional principle:

The weaker Bonded Disc Pack is raised first. It clamps the first component. Then the stronger Bonded Disc Pack is raised and clamps the second component. Alignment with the first component is achieved through pull-back action.

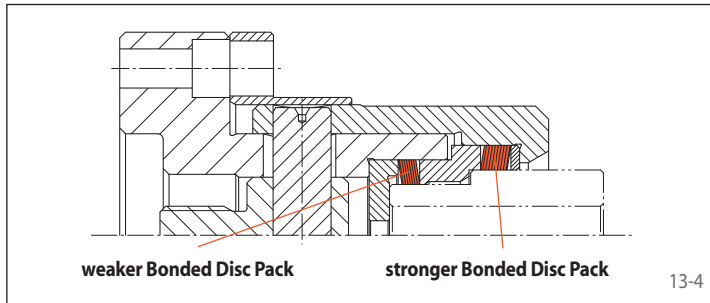

13-4

Direct Differential Bonded Disc Pack Flange Chuck

for clamping components with two different clamping diameters.

Functional principle:

The weaker Bonded Disc Pack is raised first. It centres the component and presses it against the backstop surface for alignment. Only then does the stronger Bonded Disc Pack centre the component at the second clamping point.

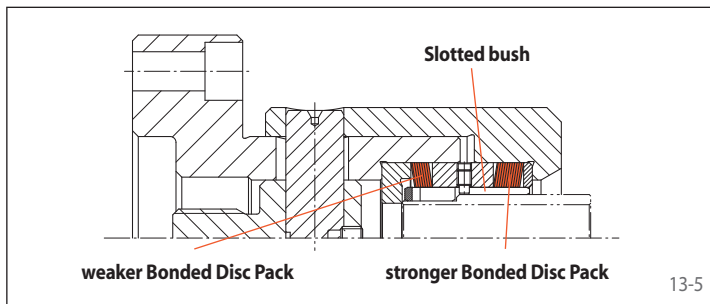

13-5

Indirect Differential Bonded Disc Pack Flange Chuck

for clamping components with two different clamping diameters on sensitive surface.

Functional principle:

The weaker Bonded Disc Pack is raised first. It centres the component and presses it against the backstop surface for alignment. Only then does the stronger Bonded Disc Pack centre the component at the second clamping point. By changing the slotted bush different components can be clamped.

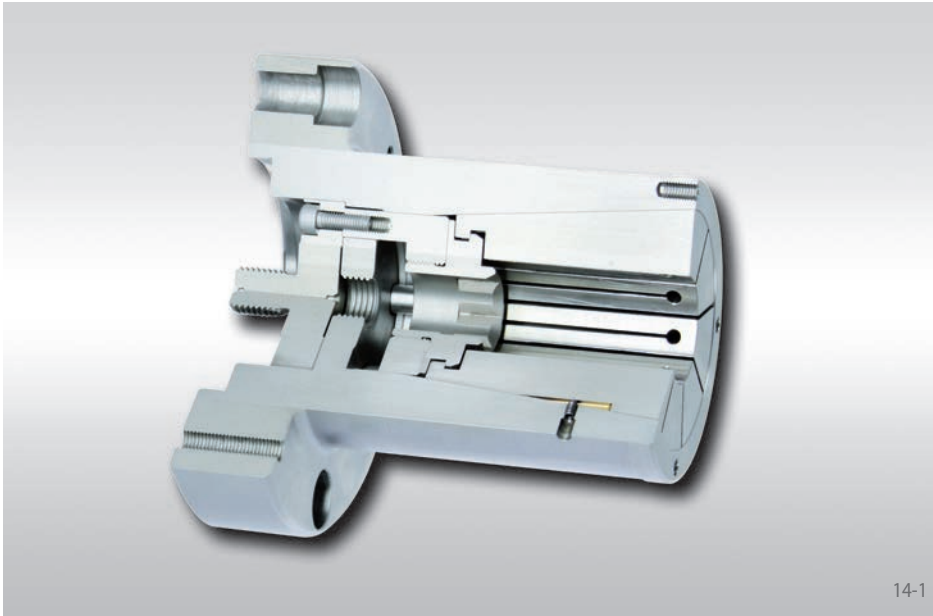

14-1

Features

- For clamping diameters from 7,2 mm to 73,6 mm
- High true running accuracy $\leq 0,01$ mm
- Permissible component tolerance up to IT15
- Extended insertion depth
- Pull-back against external backstop surface or internal backstop pin by the customer
- For thin-walled or solid components

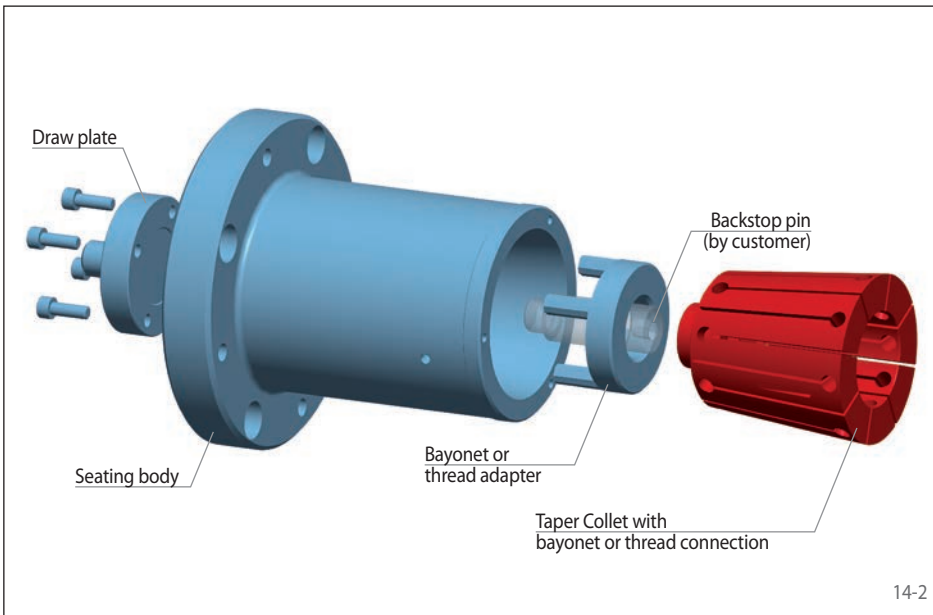

14-2

Configuration

The Taper Collet Flange Chuck consists of a draw plate, a seating body, a bayonet or threaded adapter and a Taper Collet. Depending on its size, the Taper Collet has a bayonet or threaded connection. It is taken up by the seating body in a form-fitting connection and connected via the bayonet or threaded connection with the bayonet or threaded adapter. The Taper Collet Flange Chuck is attached to the machine with the seating body. The Clamping Fixture is actuated by the draw plate, which is connected to the machine power actuating unit.

Intermediate Flanges and Spring Force Actuators are shown starting on page 58.

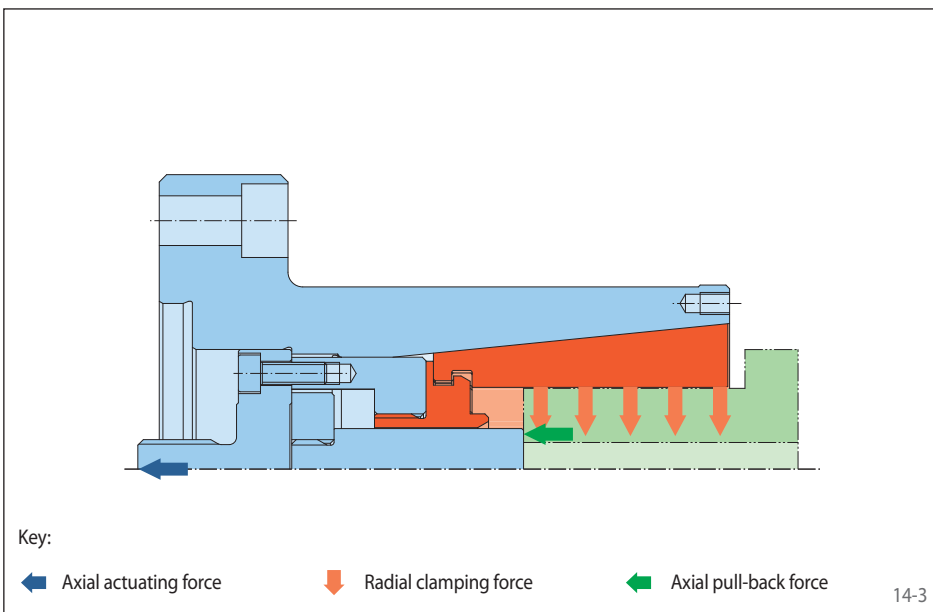

14-3

Clamping principle

For clamping, the Taper Collet is pulled against the seating body. The component is centred, pressed against the backstop and aligned flush.

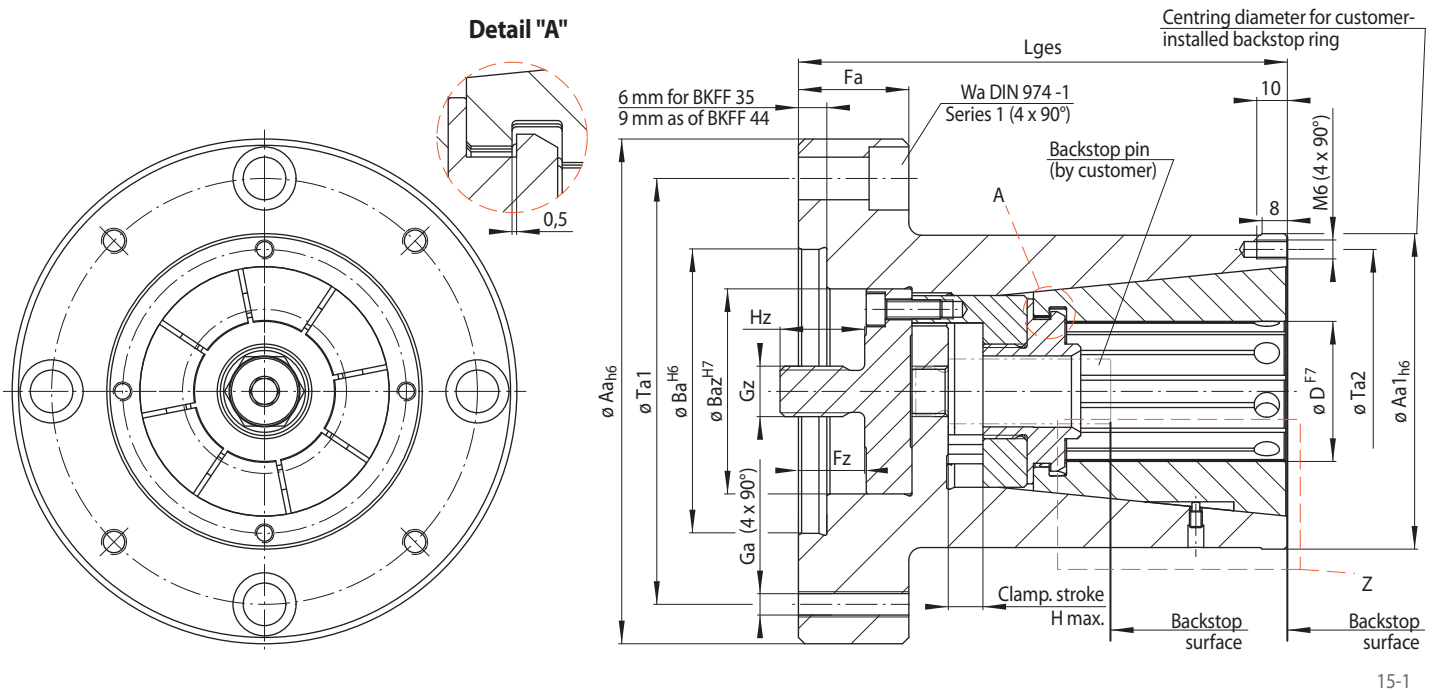

Insertion depth Le

The minimum insertion depth $Le_{min.}$ is measured from the face of the seating body and derived according to the following formula from the length of the chamfer Lf of the component and the constant K :

$$Le_{min.} = K + Lf$$

Please note

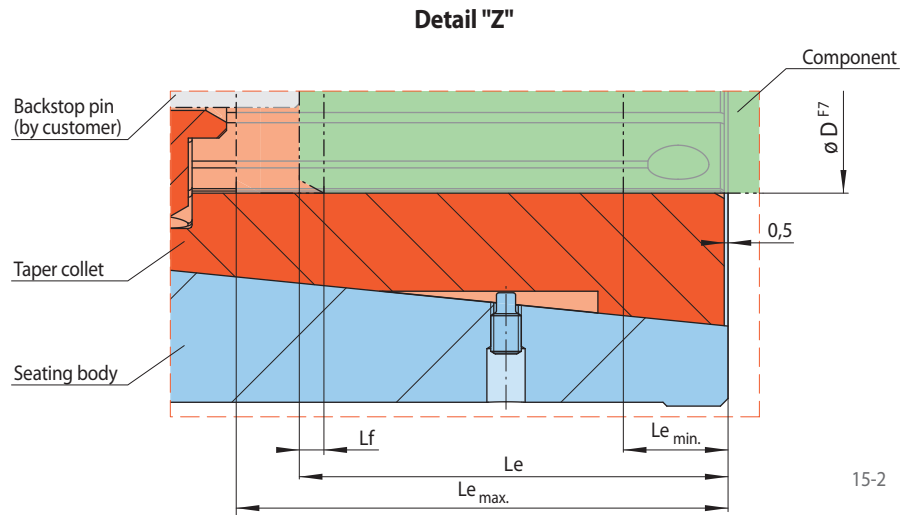
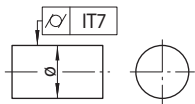

Size	Clamping range	Maximum diameter change*	Max. transmissible torque**	Max. actuating force**	Aa	Aa1	Ba	Baz	Fa	Fz	Ga	Gz	H max.	Hz	K	Le max. ³⁾	Lges	Ta1	Ta2	Wa
	D ¹⁾ mm	Δ D mm	M ²⁾ Nm	F N	mm	mm	mm	mm	mm	mm	mm	mm	mm	mm	mm	mm	mm	mm	mm	mm
BKFF 35	14,60 - 7,20	0,6	10 - 20	8500	90	55	50	27	20	10	M 6	M 10	3,5	14	9,5	39,5	93,5	70	45	8
BKFF 44	23,60 - 14,40	0,8	27 - 42	11000	120	70	60	50	30	19	M 8	M 16	5,0	18	12,5	40,5	110	95	60	10
BKFF 56	33,60 - 23,40	1,2	63 - 87	16000	120	75	60	50	30	19	M 8	M 16	7,0	18	21,5	44,5	119	95	65	10
BKFF 79	51,60 - 33,40	2,0	158 - 234	28000	160	100	90	65	35	21	M 8	M 16	11,0	22	25,5	64,5	155	135	90	12
BKFF 110	73,60 - 51,40	2,4	346 - 479	40000	200	135	125	90	35	22,5	M 8	M 20	13,0	25	29,5	88,5	190	175	125	12

* of the clamping diameter of the Clamping Element. ** for clamping with pull-back action.

¹⁾ Please note the standard clamping ranges according to the table on the next page „Clamping Elements Taper Collets BKFF“.

²⁾ The lower value refers to the smallest clamping diameter of the respective size, the higher value to the largest. For values between the two see the table "Taper Collet Clamping Elements" from page 16.

³⁾ Maximum insertion depth (corresponds to clamping length)

Example for ordering

Please indicate the size of the Clamping Fixture and the clamping range of the requested Taper Collet, in your order:

Size: BKFF 35
Clamping range: 10,20 - 9,60 mm
➔ BKFF 35-10,20-9,60

Clamping Elements Taper Collets BKF

for setup of Taper Collet Flange Chucks BKFF
to different clamping diameters within a given size

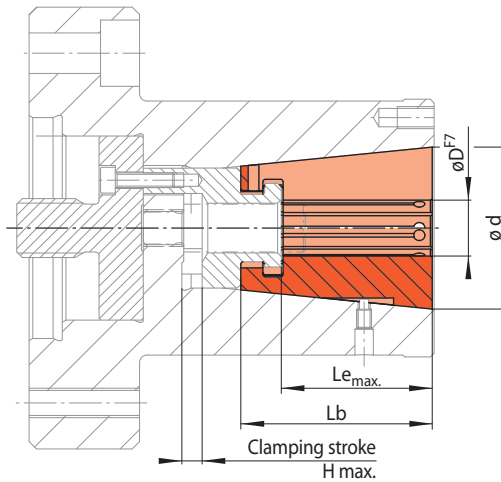

Taper Collet with bayonet connection

16-1

Size BKF ...	Clamping range	Max. transmissible torque*	Max. actuating force*	H max.**	Lb	Le max.	Art.-No.
d mm	D mm	M Nm	F N	mm	mm	mm	2198-
35	7,80 - 7,20	10,0	8500	3,5	50	39,5	035609-007.80
	8,20 - 7,60	11,0	8500	3,5	50	39,5	035609-008.20
	8,60 - 8,00	11,5	8500	3,5	50	39,5	035609-008.60
	9,00 - 8,40	12,0	8500	3,5	50	39,5	035609-009.00
	9,40 - 8,80	12,5	8500	3,5	50	39,5	035609-009.40
	9,80 - 9,20	13,0	8500	3,5	50	39,5	035609-009.80
	10,20 - 9,60	13,5	8500	3,5	50	39,5	035609-010.20
	10,60 - 10,00	14,5	8500	3,5	50	39,5	035609-010.60
	11,00 - 10,40	15,0	8500	3,5	50	39,5	035609-011.00
	11,40 - 10,80	15,5	8500	3,5	50	39,5	035609-011.40
	11,80 - 11,20	16,0	8500	3,5	50	39,5	035609-011.80
	12,20 - 11,60	16,5	8500	3,5	50	39,5	035609-012.20
	12,60 - 12,00	17,0	8500	3,5	50	39,5	035609-012.60
	13,00 - 12,40	17,5	8500	3,5	50	39,5	035609-013.00
	13,40 - 12,80	18,5	8500	3,5	50	39,5	035609-013.40
13,80 - 13,20	19,0	8500	3,5	50	39,5	035609-013.80	
14,20 - 13,60	19,5	8500	3,5	50	39,5	035609-014.20	
14,60 - 14,00	20,0	8500	3,5	50	39,5	035609-014.60	
44	15,20 - 14,40	27	11 000	5,0	52	40,5	044600-015.20
	15,80 - 15,00	28	11 000	5,0	52	40,5	044600-015.80
	16,40 - 15,60	29	11 000	5,0	52	40,5	044600-016.40
	17,00 - 16,20	30	11 000	5,0	52	40,5	044600-017.00
	17,60 - 16,80	31	11 000	5,0	52	40,5	044600-017.60
	18,20 - 17,40	32	11 000	5,0	52	40,5	044600-018.20
	18,80 - 18,00	33	11 000	5,0	52	40,5	044600-018.80
	19,40 - 18,60	34	11 000	5,0	52	40,5	044600-019.40
	20,00 - 19,20	35	11 000	5,0	52	40,5	044600-020.00
	20,60 - 19,80	37	11 000	5,0	52	40,5	044600-020.60
	21,20 - 20,40	38	11 000	5,0	52	40,5	044600-021.20
	21,80 - 21,00	39	11 000	5,0	52	40,5	044600-021.80
	22,40 - 21,60	40	11 000	5,0	52	40,5	044600-022.40
	23,00 - 22,20	41	11 000	5,0	52	40,5	044600-023.00
	23,60 - 22,80	42	11 000	5,0	52	40,5	044600-023.60

* for clamping with pull-back action.

** Clamping stroke H max. describes the load limit of the Clamping Element while activation without component.
Maximum insertion depth $L_{e,max.}$ corresponds to clamping length.

Clamping Elements Taper Collets BKF

for setup of Taper Collet Flange Chucks BKFF
to different clamping diameters within a given size

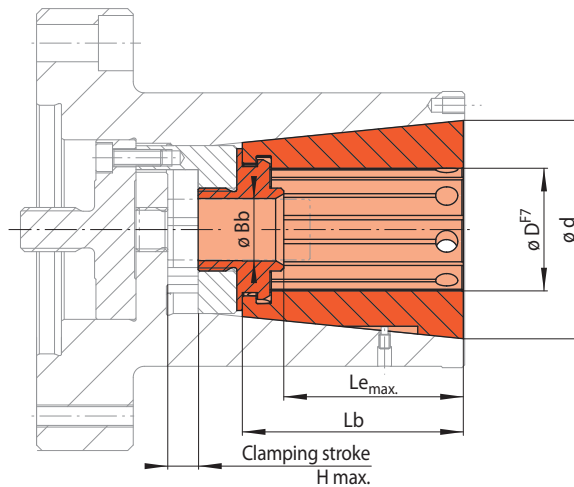

Taper Collect with thread connection

17-1

Size BKF ...	Clamping range	Max. transmissible torque*	Max. actuating force*	Bb	H max.**	Lb	Le max.	Art.-No.
d mm	D mm	M Nm	F N	mm	mm	mm	mm	3198-
56	24,60 - 23,40	63	16000	17,5	7,0	55	44,5	056609-024.60
	25,60 - 24,40	66	16000	17,5	7,0	55	44,5	056609-025.60
	26,60 - 25,40	69	16000	17,5	7,0	55	44,5	056609-026.60
	27,60 - 26,40	71	16000	17,5	7,0	55	44,5	056609-027.60
	28,60 - 27,40	74	16000	17,5	7,0	55	44,5	056609-028.60
	29,60 - 28,40	76	16000	17,5	7,0	55	44,5	056609-029.60
	30,60 - 29,40	79	16000	17,5	7,0	55	44,5	056609-030.60
	31,60 - 30,40	82	16000	17,5	7,0	55	44,5	056609-031.60
	32,60 - 31,40	84	16000	17,5	7,0	55	44,5	056609-032.60
33,60 - 32,40	87	16000	16000	17,5	7,0	55	44,5	056609-033.60
79	35,40 - 33,40	158	28000	22,5	11,0	80	64,5	079600-035.40
	37,20 - 35,20	166	28000	22,5	11,0	80	64,5	079600-037.20
	39,00 - 37,00	174	28000	22,5	11,0	80	64,5	079600-039.00
	40,80 - 38,80	183	28000	22,5	11,0	80	64,5	079600-040.80
	42,60 - 40,60	191	28000	22,5	11,0	80	64,5	079600-042.60
	44,40 - 42,40	200	28000	22,5	11,0	80	64,5	079600-044.40
	46,20 - 44,20	208	28000	22,5	11,0	80	64,5	079600-046.20
	48,00 - 46,00	217	28000	22,5	11,0	80	64,5	079600-048.00
	49,80 - 47,80	225	28000	22,5	11,0	80	64,5	079600-049.80
51,60 - 49,60	234	28000	22,5	11,0	80	64,5	079600-051.60	
110	53,80 - 51,40	346	40000	22,3	13,0	110	88,5	110600-053.80
	56,00 - 53,60	360	40000	22,3	13,0	110	88,5	110600-056.00
	58,20 - 55,80	375	40000	22,3	13,0	110	88,5	110600-058.20
	60,40 - 58,00	390	40000	22,3	13,0	110	88,5	110600-060.40
	62,60 - 60,20	405	40000	22,3	13,0	110	88,5	110600-062.60
	64,80 - 62,40	419	40000	22,3	13,0	110	88,5	110600-064.80
	67,00 - 64,60	443	40000	22,3	13,0	110	88,5	110600-067.00
	69,20 - 66,80	449	40000	22,3	13,0	110	88,5	110600-069.20
	71,40 - 69,00	464	40000	22,3	13,0	110	88,5	110600-071.40
73,60 - 71,20	479	40000	22,3	13,0	110	88,5	110600-073.60	

* for clamping with pull-back action. ** Clamping stroke H max. describes the load limit of the Clamping Element while activation without component. Maximum insertion depth Le_{max} corresponds to clamping length.

Example for ordering

Please indicate the size of the Clamping Element and the clamping range of the requested Taper Collet, in your order:

Size: BKF 35
Clamping range: 10,20 - 9,60 mm
➔ BKF 35-10,20-9,60

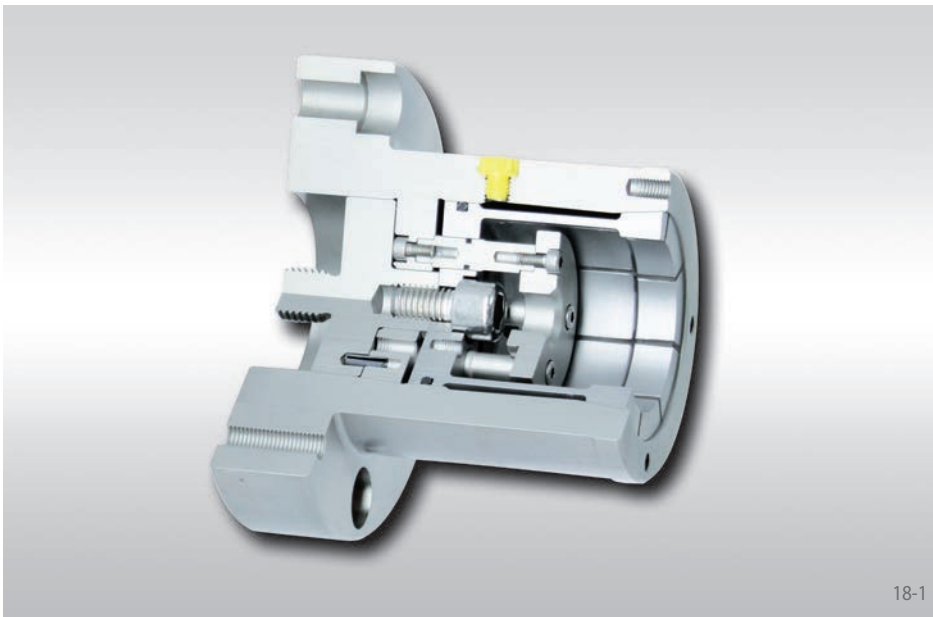

18-1

Features

- For clamping diameters from 15 mm to 206 mm
- High true running accuracy $\leq 0,01$ mm
- Permissible component tolerance up to IT13
- Extended insertion depth
- Pull-back against external backstop surface or internal backstop ring by the customer
- Hand clamping optional possible
- Impervious to ingress of foreign objects due to the rubberized slots in the Taper Sleeve

Configuration

The Taper Sleeve Flange Chuck consists of a draw plate, a seating body and a Taper Sleeve. A plate with a threaded bore for hand clamping is optionally available. The Taper Sleeve Flange Chuck is attached to the machine with the seating body. The Clamping Fixture is actuated by the draw plate, which is connected to the machine power actuating unit.

Intermediate Flanges and Spring Force Actuators are shown starting on page 58.

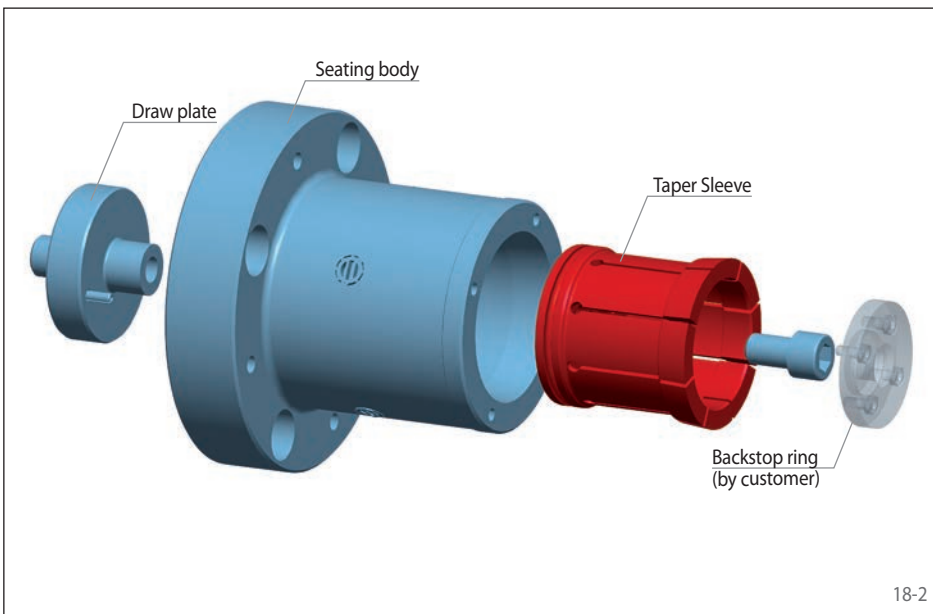

18-2

Clamping principle

For clamping, the Taper Sleeve is pulled against the seating body. The component is centred, pressed against the backstop and aligned flush.

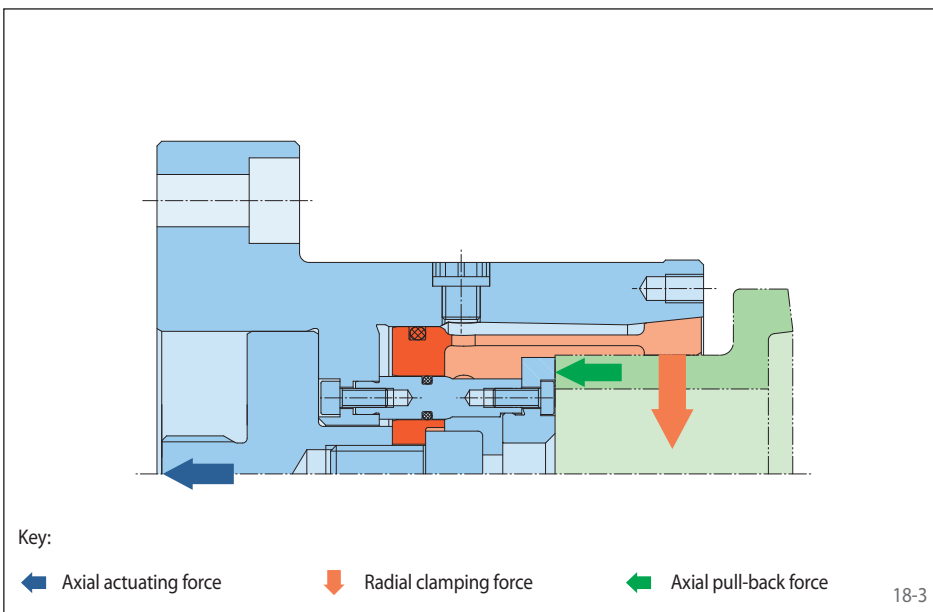

18-3

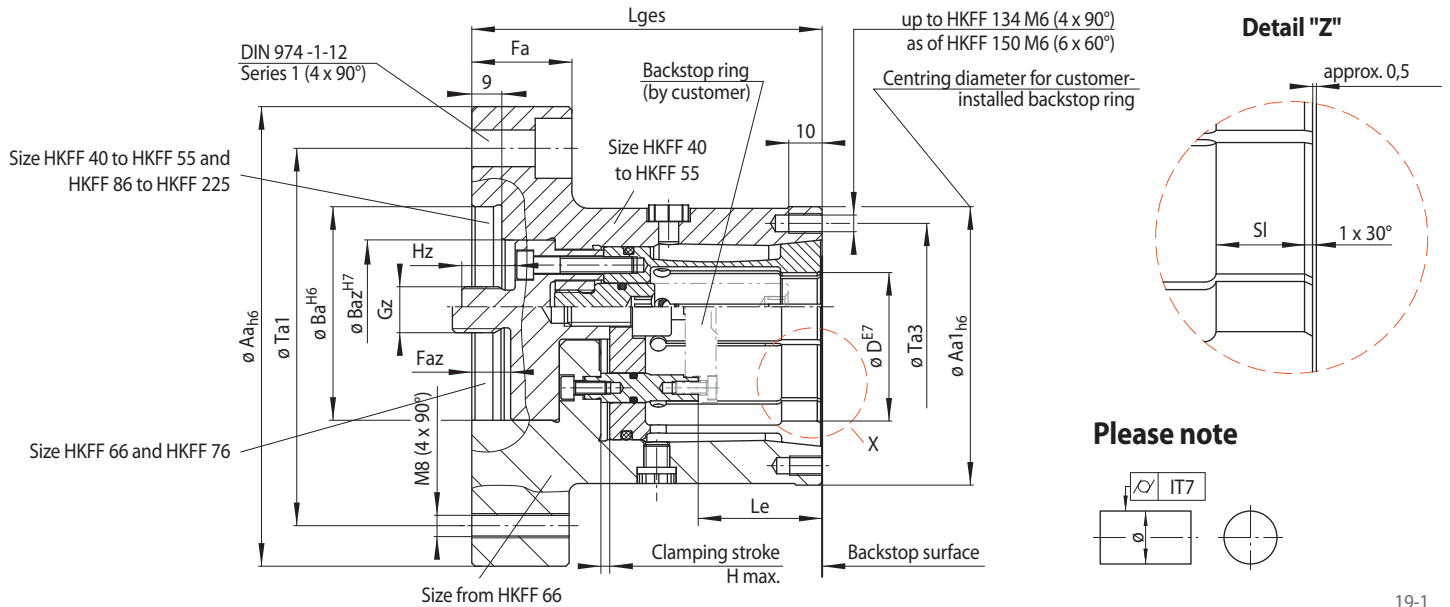

19-1

Size	Achievable clamping diameter D* mm	Maximum diameter change** Δ D mm	Max. transmissible torque*** M ¹⁾ Nm	Max. actuating force*** F N	Aa mm	Aa1 mm	Ba mm	Baz mm	Fa mm	Faz mm	Gz mm	H max. mm	Hz mm	Le mm	Lges mm	Sl mm	Ta1 mm	Ta3 mm
HKFF 40	15,00 - 20,50	0,5	20 - 30	10000	120	60	40	40	30	13	M 12	2,7	16	50,2	105	10,5	95	50
HKFF 45	20,00 - 30,50	0,5	50 - 80	17000	120	65	40	40	30	13	M 12	2,7	16	55,2	110	10,5	95	55
HKFF 55	30,00 - 40,50	0,5	90 - 125	20000	120	75	40	40	30	13	M 12	2,7	16	55,2	110	10,5	95	65
HKFF 66	40,00 - 50,50	0,5	130 - 160	20000	140	90	60	-	30	19,0	M 16	2,7	18	38,2	115	11	115	78
HKFF 76	50,00 - 60,50	0,5	160 - 190	20000	140	95	60	-	30	19,0	M 16	2,7	18	38,2	115	11	115	85
HKFF 86	60,00 - 70,50	0,5	240 - 280	25000	160	110	90	70	30	12,0	M 16	2,7	18	38,2	108	11	135	98
HKFF 96	70,00 - 80,50	0,5	280 - 320	25000	160	115	90	70	30	12,0	M 16	2,7	18	38,2	108	11	135	106
HKFF 106	80,00 - 90,50	0,5	390 - 440	30000	185	135	125	84	30	12,0	M 20	2,9	27	39,9	123	13	160	120
HKFF 114	90,00 - 100,50	0,5	440 - 490	30000	185	140	125	84	30	12,0	M 20	2,9	27	39,9	123	13	160	128
HKFF 124	100,00 - 110,50	0,5	570 - 630	35000	200	155	125	105	30	12,0	M 20	2,9	27	39,9	123	13	175	140
HKFF 134	110,00 - 120,50	0,5	630 - 680	35000	225	165	125	105	30	12,0	M 20	2,9	27	39,9	123	13	200	150
HKFF 150	120,00 - 131,00	1,0	685 - 740	35000	225	180	125	80	30	15,5	M 20	6,0	27	57,0	150	14	200	165
HKFF 160	130,00 - 146,00	1,0	740 - 825	35000	250	190	175	80	35	15,5	M 20	6,0	27	62,0	155	14	225	174
HKFF 175	145,00 - 161,00	1,0	820 - 910	35000	250	205	175	80	35	15,5	M 20	6,0	27	72,0	165	14	225	190
HKFF 190	160,00 - 176,00	1,0	905 - 1000	35000	275	225	200	80	40	15,5	M 20	6,0	27	71,0	173	14	250	208
HKFF 205	175,00 - 191,00	1,0	990 - 1080	35000	315	240	240	80	45	15,5	M 20	6,0	27	78,0	180	14	280	222
HKFF 225	190,00 - 206,00	1,0	1075 - 1165	35000	315	260	240	80	45	15,5	M 20	6,0	27	83,0	185	14	280	242

* Clamping diameter adjustable to two places after the decimal point • ** of the clamping diameter of the Clamping Element. • *** for clamping with pull-back action.
¹⁾ The lower value refers to the smallest clamping diameter of the respective size, the higher value to the largest. For values between the two can be determined through interpolation.

Example for ordering

Please indicate the size of the Clamping Fixture and the clamping diameter of your component, including component tolerance, in your order:

Size: HKFF 66
 Clamping diameter: 50,47 mm
 Component tolerance: h6
 ➔ HKFF 66-50,47h6

Clamping Elements Taper Sleeves HKF

for setup of Taper Sleeve Flange Chucks HKFF
to different clamping diameters within a given size

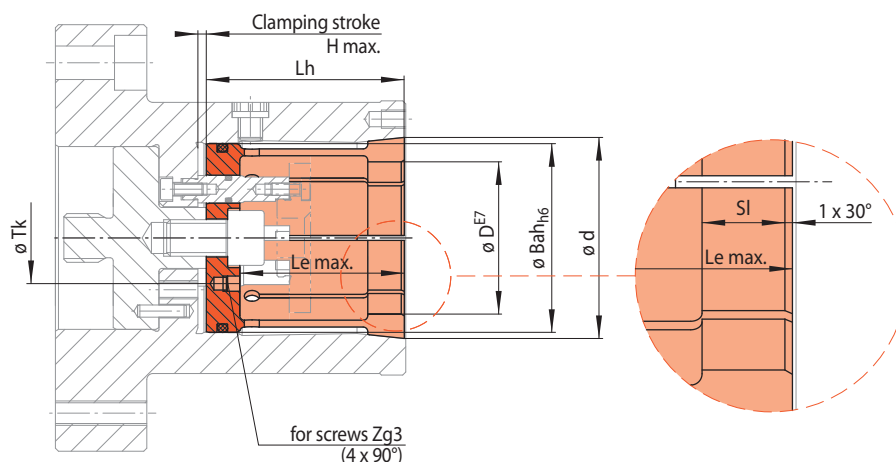

20-1

Size HKF ...	Achievable clamping diameter	Maximum diameter change**	Max. transmissible torque***	Max. actuating force***	Bah	H max. ****	Le max.	Lh	SI	Tk	Zg3	Art.-No.
d mm	D* mm	Δ D mm	M ¹⁾ Nm	F N	mm	mm	mm	mm	mm	mm		3198-
40	15,00 - 18,00	0,5	20 - 25	10000	36	2,7	50,2	65	10,5	-	-	040601
40	17,50 - 20,50	0,5	25 - 30	10000	36	2,7	50,2	65	10,5	-	-	040600
45	20,00 - 25,50	0,5	50 - 68	17000	40	2,7	55,2	70	10,5	-	-	045601
45	25,00 - 30,50	0,5	68 - 80	17000	40	2,7	55,2	70	10,5	-	-	045600
55	30,00 - 40,50	0,5	90 - 125	20000	50	2,7	55,2	70	10,5	-	-	055600
66	40,00 - 50,50	0,5	130 - 160	20000	62	2,7	54,0	65	11,0	30	M 5	066600
76	50,00 - 60,50	0,5	160 - 190	20000	72	2,7	54,0	65	11,0	30	M 5	076600
86	60,00 - 70,50	0,5	240 - 280	25000	82	2,7	54,0	65	11,0	30	M 5	086600
96	70,00 - 80,50	0,5	280 - 320	25000	92	2,7	54,0	65	11,0	30	M 5	096600
106	80,00 - 90,50	0,5	390 - 440	30000	102	2,9	64,0	78	13,0	38	M 6	106600
114	90,00 - 100,50	0,5	440 - 490	30000	110	2,9	64,0	78	13,0	38	M 6	114600
124	100,00 - 110,50	0,5	570 - 630	35000	120	2,9	64,0	78	13,0	38	M 6	124600
134	110,00 - 120,50	0,5	630 - 680	35000	130	2,9	64,0	78	13,0	38	M 6	134600
150	120,00 - 131,00	1,0	685 - 740	35000	143	6,0	78,0	95	14,0	38	M 6	150600
160	130,00 - 146,00	1,0	740 - 825	35000	155	6,0	83,0	100	14,0	38	M 6	160600
175	145,00 - 161,00	1,0	820 - 910	35000	170	6,0	92,0	110	14,0	38	M 6	175600
190	160,00 - 176,00	1,0	905 - 1 000	35000	185	6,0	95,0	118	14,0	38	M 6	190600
205	175,00 - 191,00	1,0	990 - 1 080	35000	200	6,0	102	125	14,0	38	M 6	205600
225	190,00 - 206,00	1,0	1 075 - 1 165	35000	220	6,0	107	130	14,0	38	M 6	225600

* Clamping diameter adjustable to two places after the decimal point • ** of the clamping diameter of the Clamping Element. • *** for clamping with pull-back action.

**** Clamping stroke H max. describes the load limit of the Clamping Element while activation without component.

1) The lower value refers to the smallest clamping diameter of the respective size, the higher value to the largest. For values between the two can be determined through interpolation.

Example for ordering

Please indicate the size of the Clamping Element and the clamping diameter of your component, including component tolerance, in your order:

Size: HKF 66
Clamping diameter: 50,47 mm
Component tolerance: h6

➔ HKF 66-50,47h6

for setup of Taper Sleeve Flange Chucks

Assembly group for hand clamping (optional)

for components with central through bore holes

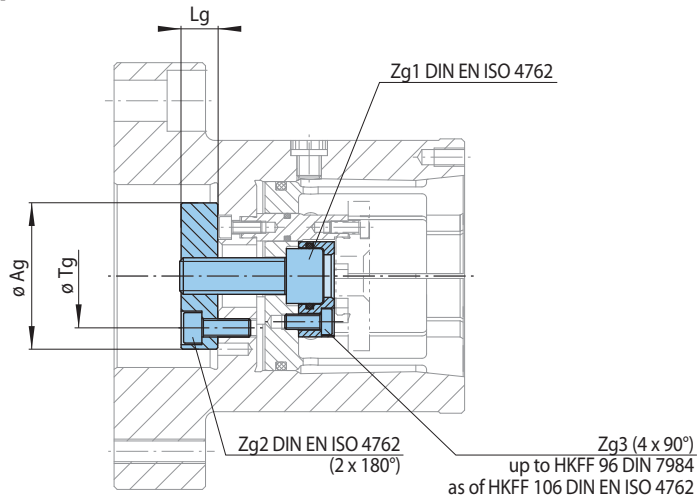

21-1

for size*	Max. permissible tightening torque M_A Nm	Ag mm	Lg mm	Tg mm	Zg1	Zg2	Zg3	Art.-No. 3128-
HKFF 66	40	48	12	34	M 12x35	M 6x16	M 5x12	048902
HKFF 76	40	48	12	34	M 12x35	M 6x16	M 5x12	048901
HKFF 86	49	48	12	34	M 12x35	M 6x16	M 5x12	048901
HKFF 96	49	48	12	34	M 12x35	M 6x20	M 5x12	048901
HKFF 106	77	68	15	54	M 16x45	M 6x20	M 6x20	068901
HKFF 114	77	68	15	54	M 16x45	M 6x20	M 6x20	068901
HKFF 124	90	68	15	54	M 16x45	M 6x20	M 6x20	068901
HKFF 134	90	68	15	54	M 16x45	M 6x20	M 6x20	068901
HKFF 150	90	68	15	54	M 16x55	M 6x20	M 6x20	068902
HKFF 160	90	68	15	54	M 16x55	M 6x20	M 6x20	068902
HKFF 175	90	68	15	54	M 16x55	M 6x20	M 6x20	068902
HKFF 190	90	68	15	54	M 16x60	M 6x20	M 6x20	068903
HKFF 205	90	68	15	54	M 16x60	M 6x20	M 6x20	068903
HKFF 225	90	68	15	54	M 16x60	M 6x20	M 6x20	068903

* Assembly group for hand clamping is not available for Taper Sleeve Flange Chucks HKFF 40 to HKFF 50.



22-1

Features

- For clamping diameters from 90 mm to 260 mm
- High true running accuracy $\leq 0,01$ mm
- Permissible component tolerance up to IT11
- Very short clamping fixture length
- Short clamping length
- Pull-back against internal backstop pins, external backstop surface or external backstop ring by the customer
- Hand clamping optional possible
- Rubberized slots in the Flat Element

Configuration

The Flat Element Flange Chuck consists of a seating body with backstop pins, a Flat Element and a draw bolt. An assembly for hand clamping is optionally available. The Flat Element Flange Chuck is attached to the machine with the seating body. The Clamping Fixture is actuated by the draw bolt, which is connected to the machine power actuating unit.

Intermediate Flanges and Spring Force Actuators are shown starting on page 58.

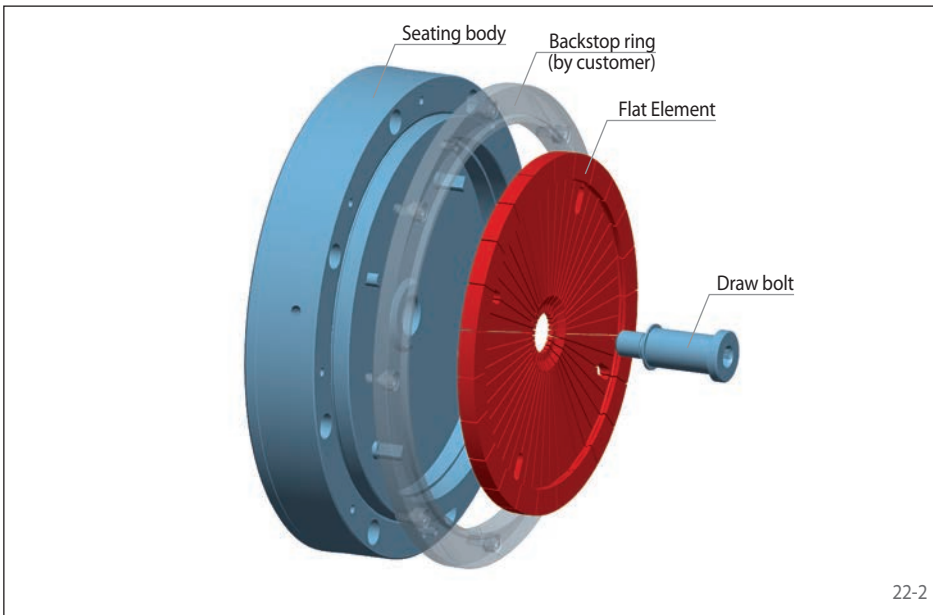

22-2

Clamping principle

The Flat Element sits pre-loaded in the seating diameter of the seating body. For clamping, the Flat Element is elastically deformed by the axial actuation force. The component is centred, pressed against the backstop and aligned flush.

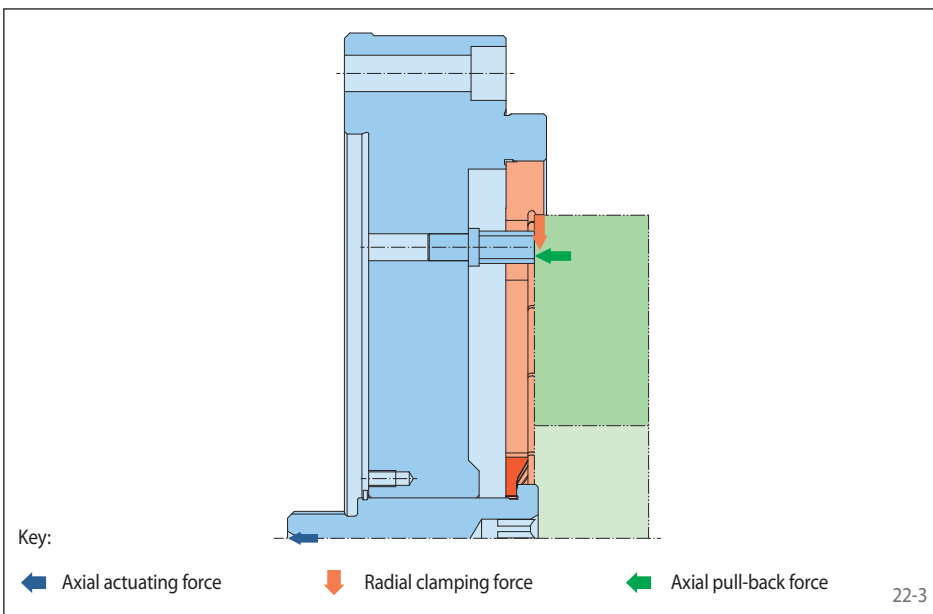

22-3

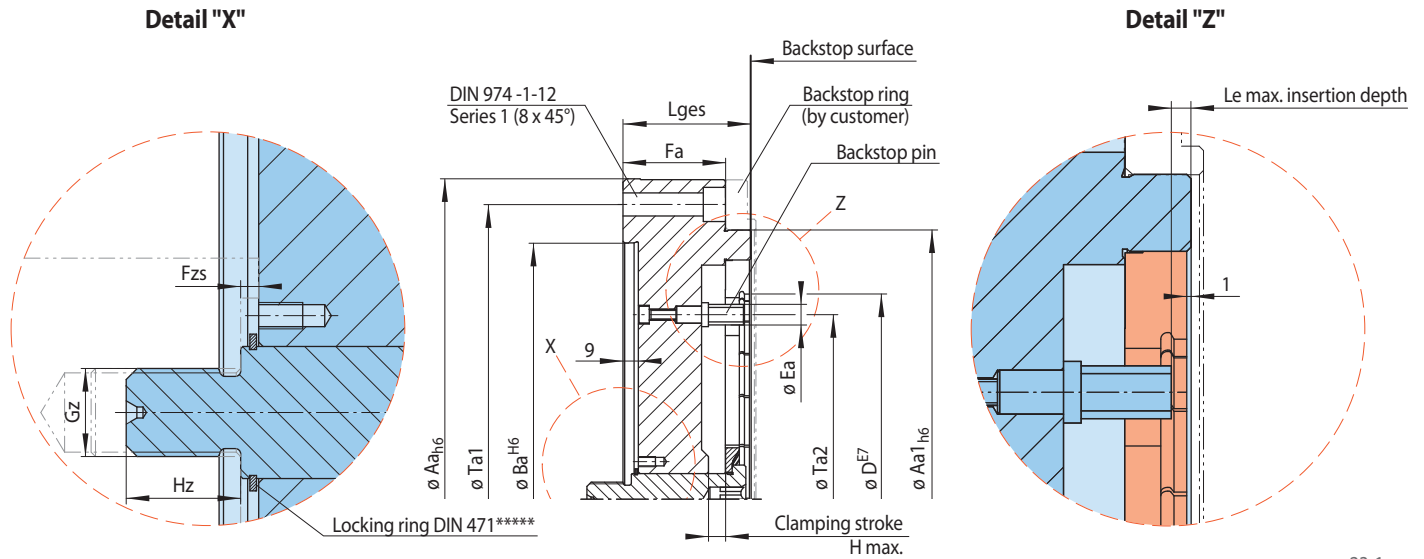

23-1

Size	Achievable clamping diameter D* mm	Maximum diameter change** ΔD mm	Max. transmissible torque*** M ¹⁾ Nm	Max. actuating force*** F N	Aa mm	Aa1 mm	Ba mm	Ea mm	Fa mm	Fzs mm	Gz mm	H max. mm	Hz mm	Le max. mm	Lges mm	Ta1 mm	Ta2 mm	Y ****
KFFF 110	90 - 100	0,27	550 - 610	14200	200	150	125	5,5	34,5	4,0	M 12	3,2	18	5	45,5	175	80,5	3
KFFF 120	100 - 110	0,27	680 - 740	14200	200	150	125	10	34,5	4,0	M 12	3,6	18	5	45,5	175	85,5	3
KFFF 130	110 - 120	0,30	730 - 780	13750	225	170	125	10	34,5	4,0	M 12	4,0	18	5	45,5	200	95,0	3
KFFF 140	120 - 130	0,33	780 - 840	13750	225	170	125	10	34,5	4,0	M 12	4,4	18	5	45,5	200	104	3
KFFF 155	130 - 140	0,36	1250 - 1300	19600	250	200	175	10	42,5	3,6	M 16	4,8	22	6	55,5	225	114	4
KFFF 170	140 - 155	0,40	1350 - 1500	19600	250	200	175	10	42,5	3,6	M 16	5,4	22	6	55,5	225	124	4
KFFF 185	155 - 170	0,46	1450 - 1600	19600	275	225	200	10	42,5	3,6	M 16	6,1	22	6	55,5	250	139	4
KFFF 200	170 - 185	0,50	1650 - 1750	19600	275	225	200	10	42,5	3,6	M 16	6,7	22	6	55,5	250	153	4
KFFF 220	185 - 200	0,56	1750 - 1850	18650	315	250	240	12	42,5	3,6	M 16	7,2	22	6	55,5	280	165	4
KFFF 240	200 - 220	0,50	2950 - 3350	29450	375	315	300	12	60,0	4,0	M 20	8,0	26	6	75,0	345	180	4
KFFF 260	220 - 240	0,66	3650 - 3900	33350	375	315	300	12	60,0	4,0	M 20	9,0	26	6	75,0	345	200	4
KFFF 280	240 - 260	0,73	4050 - 4350	34350	375	315	300	14	60,0	4,0	M 20	10,0	26	6	75,0	345	216	4

* Clamping diameter adjustable to two places after the decimal point. ** of the clamping diameter of the Clamping Element. *** for clamping with pull-back action. **** Y = Number of backstop pins on pitch circle diameter Ta2. ***** The locking ring prevents loss of the draw bolt during transport and storage of the Clamping Fixture. It must be removed prior to installation and commissioning.

¹⁾ The lower value refers to the smallest clamping diameter of the respective size, the higher value to the largest. For values between the two can be determined through interpolation.

Example for ordering

Please indicate the size of the Clamping Fixture, the clamping diameter of your component, including component tolerance, and the insertion depth in your order:

Size: KFFF 120
 Clamping diameter: 105,47 mm
 Component tolerance: h6
 Insertion depth: 2,8 mm

➔ KFFF 120-105,47h6-2,8

for setup of Flat Element Flange Chucks KFFF
to different clamping diameters within a given size

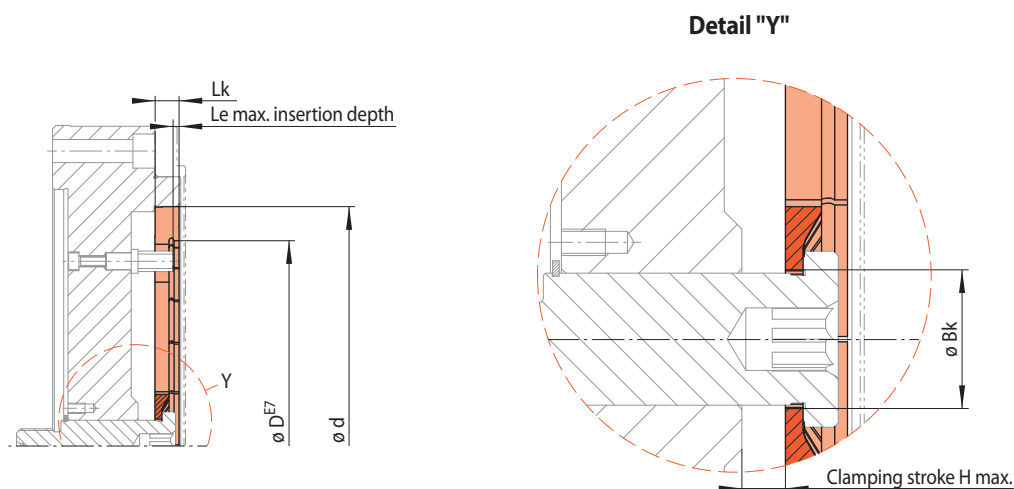

24-1

Size KFF ...	Achievable clamping diameter	Maximum diameter change**	Max. transmissible torque***	Max. actuating force***	Bk	H max. ****	Le max.	Lk	Art.-No.
d mm	D* mm	Δ D mm	M ¹⁾ Nm	F N	mm	mm	mm	mm	1190-
42	30 - 36	0,15	20 - 24	2700	10,5	1,0	2	6	042002
47	35 - 41	0,15	54 - 61	5900	10,5	1,0	2	6	047002
52	40 - 46	0,15	69 - 78	5700	10,5	1,2	2	6	052002
62	45 - 54	0,20	120 - 140	9800	12,5	1,4	3	8	062002
70	52 - 62	0,20	155 - 185	9500	12,5	1,8	3	8	070002
80	62 - 72	0,21	215 - 245	9200	12,5	2,2	3	8	080002
90	72 - 80	0,21	280 - 310	8950	12,5	2,6	3	8	090002
100	80 - 90	0,27	440 - 490	14200	16,5	2,8	4	10	100002
110	90 - 100	0,27	550 - 610	14200	16,5	3,2	5	10	110002
120	100 - 110	0,27	680 - 740	14200	16,5	3,6	5	10	120002
130	110 - 120	0,30	730 - 780	13750	16,5	4,0	5	10	130002
140	120 - 130	0,33	780 - 840	13750	16,5	4,4	5	10	140002
155	130 - 140	0,36	1250 - 1300	19600	21,0	4,8	6	12	155002
170	140 - 155	0,40	1350 - 1500	19600	21,0	5,4	6	12	170002
185	155 - 170	0,46	1450 - 1600	19600	21,0	6,1	6	12	185002
200	170 - 185	0,50	1650 - 1750	19600	21,0	6,7	6	12	200002
220	185 - 200	0,56	1750 - 1850	18650	21,0	7,2	6	12	220002
240	200 - 220	0,50	2950 - 3350	29450	31,5	8,0	6	14	240002
260	220 - 240	0,66	3650 - 3900	33350	31,5	9,0	6	14	260002
280	240 - 260	0,73	4050 - 4350	34350	31,5	10,0	6	14	280002
300	260 - 280	0,74	4700 - 5050	34350	31,5	11,0	6	14	300002
325	280 - 300	0,74	4800 - 5200	29450	31,5	12,0	6	16	325002
350	300 - 325	0,74	5600 - 6100	29450	31,5	13,0	6	16	350002
375	325 - 350	0,74	6600 - 7150	29450	31,5	14,0	6	16	375002
400	350 - 375	0,86	6200 - 6700	29450	52,0	14,0	6	18	400002
425	375 - 400	0,86	7200 - 7700	29450	52,0	15,0	6	18	425002
455	400 - 425	0,86	8250 - 8750	29450	52,0	16,0	6	18	455002
485	425 - 455	0,98	6900 - 7400	24550	52,0	16,0	6	20	485002
520	455 - 485	0,98	7950 - 8450	24550	52,0	19,5	6	20	520002
560	485 - 520	0,98	9150 - 9850	24550	52,0	21,0	6	20	560002

* Clamping diameter adjustable to two places after the decimal point • ** of the clamping diameter of the Clamping Element. • *** for clamping with pull-back action.

**** Clamping stroke H max. describes the load limit of the Clamping Element while activation without component.

¹⁾ The lower value refers to the smallest clamping diameter of the respective size, the higher value to the largest. For values between the two can be determined through interpolation.

Example for ordering

Please indicate the size of the Clamping Element and the clamping diameter of your component, including component tolerance, in your order:

Size: KFF 62
Clamping diameter: 50,47 mm
Component tolerance: h6

➔ KFF 62-50,47h6

for setup of Flat Element Flange Chucks

Assembly group for hand clamping (optional)

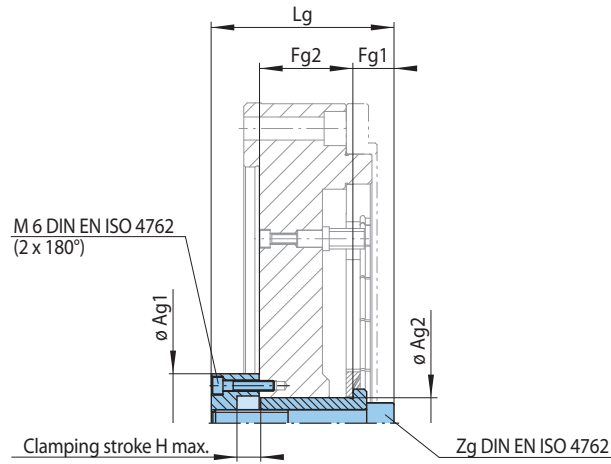

25-1

for size	Max. permissible tightening torque M_A Nm	Ag1 mm	Ag2 mm	Fg1 mm	Fg2 mm	H max. mm	Lg mm	Zg	Art.-No. 3182-
KFFF 110	25	43	16	16	27	3,2	59	M 10	022900
KFFF 120	25	43	16	16	27	3,6	59	M 10	022900
KFFF 130	24	43	16	16	27	4,0	59	M 10	022900
KFFF 140	24	43	16	16	27	4,4	59	M 10	022900
KFFF 155	40	48	20	19	35	4,8	79	M 12	028900
KFFF 170	40	48	20	19	35	5,4	79	M 12	028900
KFFF 185	40	48	20	19	35	6,1	79	M 12	028900
KFFF 200	40	48	20	19	35	6,7	79	M 12	028900
KFFF 220	38	48	20	19	35	7,2	79	M 12	028900
KFFF 240	77	58	30	24	54	8,0	106	M 16	040900
KFFF 260	88	58	30	24	54	9,0	106	M 16	040900
KFFF 280	90	58	30	24	54	10,0	106	M 16	040900

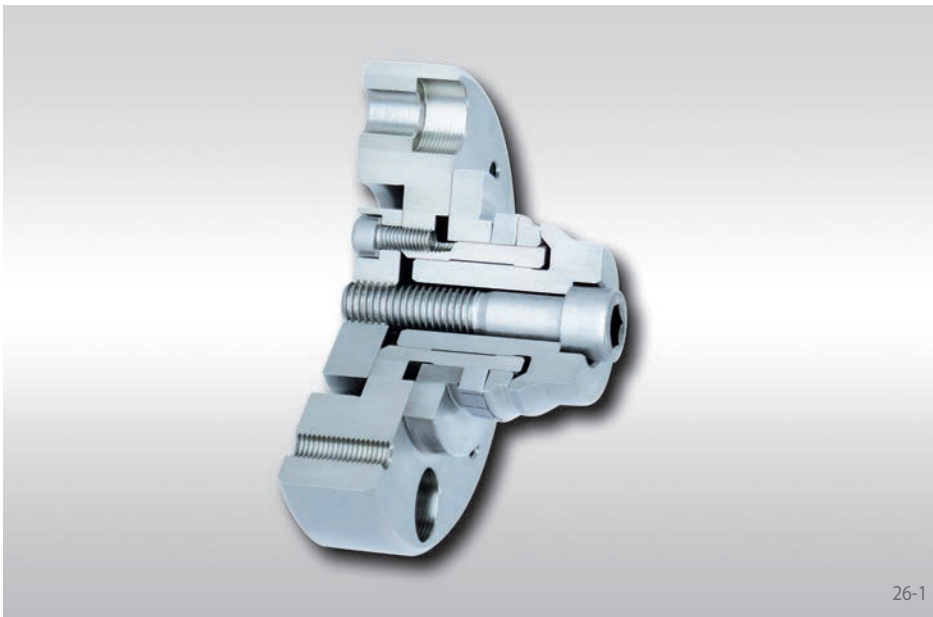

26-1

Features

- For clamping diameters from 18 mm to 140 mm
- High true running accuracy $\leq 0,01$ mm
- Permissible component tolerance up to IT11
- Short or long clamping length possible
- Pull-back against external backstop surface or external backstop ring by the customer
- For thin-walled or solid components
- Hand clamping optional possible
- Impervious to ingress of foreign objects due to the rubberized slots in the Bonded Disc Pack

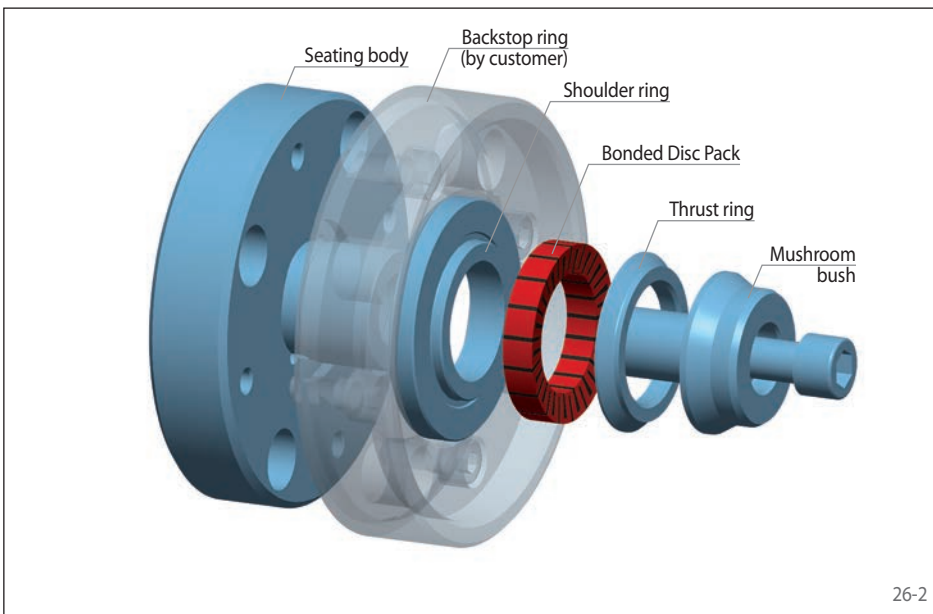

26-2

Configuration

The Bonded Disc Pack Flange Mandrel consists of a seating body, a shoulder ring, a Bonded Disc Pack, a thrust ring and a mushroom bush. A plate with a threaded bore is optionally available for hand clamping. The Bonded Disc Pack Flange Mandrel is attached to the machine with the seating body. The Clamping Fixture is actuated by the central bolt of the mushroom bush, which is connected to the machine power actuating unit. Depending on the required transmitted torque, Bonded Disc Packs of different widths may be installed. The required installation situations for the shoulder ring are shown in Fig. 27-2.

Intermediate Flanges and Spring Force Actuators are shown starting on page 58.

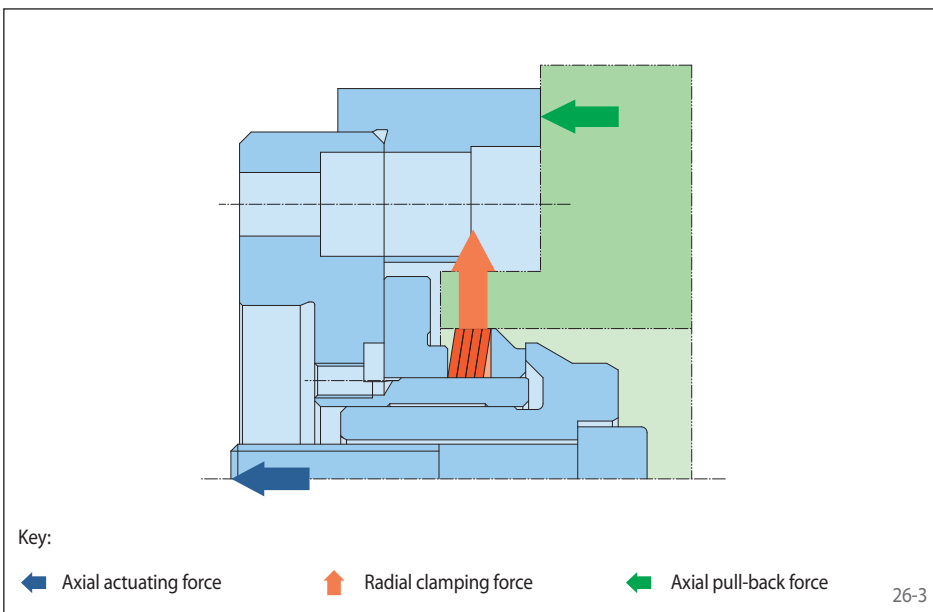

26-3

Clamping principle

The Bonded Disc Pack sits pre-loaded on the seating diameter of the seating body. When axial actuating force is applied, the Bonded Disc Pack is raised to an upright position. The component is centred, pressed against the shoulder ring or the backstop and aligned flush. The tipping movement of the Bonded Disc Pack converts the axial actuating force into a radial clamping force that is up to ten times higher.

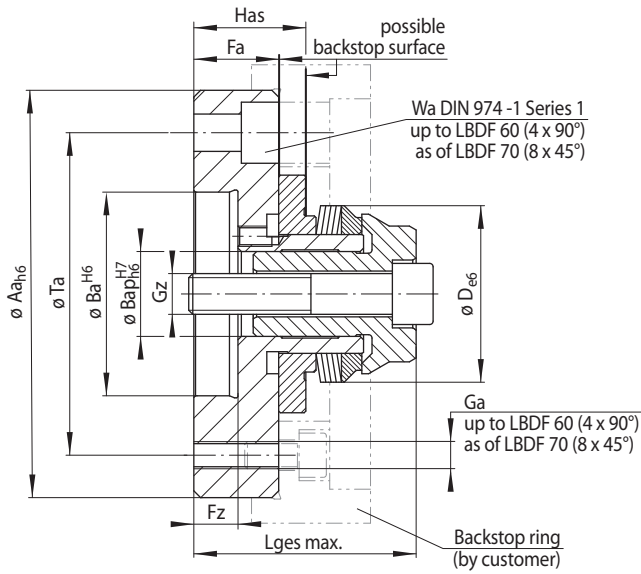

Installation situations

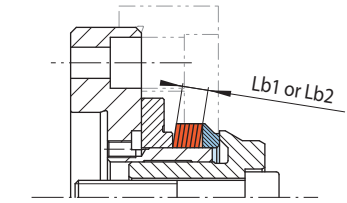

Bonded disc pack widths Lb1 and Lb2

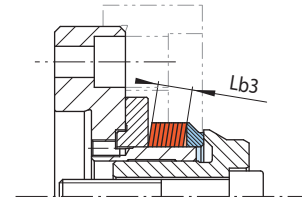

Bonded disc pack width Lb3

27-1

27-2

Size	Achievable clamping diameter D* mm	Maximum diameter change** Δ D mm	Bonded disc pack width Lb1			Bonded disc pack width Lb2			Bonded disc pack width Lb3			Aa mm	Ba mm	Bap mm	Fa mm	Fz mm	Ga mm	Gz mm	Has mm	Lges max. mm	Ta mm	Wa mm
			Lb1 mm	M Nm	Fm kN	Lb2 mm	M Nm	Fm kN	Lb3 mm	M Nm	Fm kN											
LBDF 11	18 - 22	0,10	4	7	3,1	6	11	4,7	8	15	6,3	70	37	8	20	9	M 6	M 5	25	47	50	8
LBDF 15	22 - 27	0,10	4	15	4,5	6	22	6,8	8	29	9,1	90	50	10	20	9	M 6	M 6	29,5 ¹⁾	54	70	8
	27 - 32	0,15	6	22	7,0	9	33	10,5	12	40	14,0	90	50	10	20	9	M 6	M 6	29,5 ²⁾	55	70	8
LBDF 20	32 - 37	0,15	6	39	9,6	9	50	14,4	12	60	19,2	90	50	15	20	9	M 6	M 8	28	57	70	8
	37 - 42	0,15	6	38	8,4	9	50	12,6	12	60	16,8	90	50	15	20	9	M 6	M 8	28	57	70	8
LBDF 25	37 - 42	0,15	6	60	12,0	9	90	18,0	12	120	24,0	90	50	18	25	11	M 6	M 10	34	67	70	8
	42 - 47	0,15	6	60	10,8	9	90	16,2	12	120	21,6	90	50	18	25	11	M 6	M 10	34	67	70	8
LBDF 30	42 - 47	0,15	6	80	14,4	9	130	21,6	12	170	28,8	120	60	20	27	13	M 8	M 12	35	69	95	10
	47 - 52	0,15	6	80	12,8	9	120	19,2	12	160	25,6	120	60	20	27	13	M 8	M 12	35	69	95	10
LBDF 35	47 - 52	0,15	6	120	17,2	9	190	25,8	12	250	34,4	120	60	20	25	13	M 8	M 12	33	69	95	10
	52 - 57	0,15	6	120	15,6	9	180	23,4	12	240	31,2	120	60	20	25	13	M 8	M 12	33	69	95	10
LBDF 40	52 - 57	0,15	6	160	19,6	9	250	29,4	12	330	39,2	120	60	25	30	13	M 8	M 12	41	73	95	10
	57 - 62	0,15	6	160	18,4	9	240	27,6	12	320	36,8	120	60	25	30	13	M 8	M 12	41	73	95	10
LBDF 45	57 - 62	0,15	6	210	22,4	9	320	33,6	12	420	44,8	120	60	30	35	16	M 8	M 16	48	84	95	10
	62 - 67	0,15	6	200	20,8	9	310	31,2	12	410	41,6	120	60	30	35	16	M 8	M 16	48	84	95	10
LBDF 50	67 - 70	0,15	6	250	23,2	9	380	34,8	12	500	46,4	140	60	35	30	16	M 8	M 16	40,5	79,5	115	12
	70 - 75	0,25	6	250	24,0	10	430	40,0	16	680	64,0	140	60	35	30	16	M 8	M 16	40,5 ¹⁾	80	115	12
	75 - 80	0,25	6	250	22,8	10	420	38,0	16	670	60,8	140	60	35	30	16	M 8	M 16	40,5 ¹⁾	80	115	12
LBDF 60	80 - 85	0,25	6	370	29,4	10	630	49,0	16	1000	78,4	160	90	40	35	16	M 8	M 16	49	96,5	135	12
	85 - 90	0,25	6	370	27,6	10	620	46,0	16	990	73,6	160	90	40	35	16	M 8	M 16	49	96,5	135	12
LBDF 70	90 - 95	0,25	6	510	34,8	10	860	58,0	16	1370	92,8	160	90	45	37	16	M 8	M 16	52,5	101	135	12
	95 - 100	0,25	6	510	33,0	10	850	55,0	16	1360	88,0	160	90	45	37	16	M 8	M 16	52,5	101	135	12
LBDF 80	100 - 105	0,25	6	660	39,6	10	1100	66,0	16	1760	105,6	185	125	50	45	14	M 8	M 20	69,5	121	160	12
	105 - 110	0,25	6	660	38,4	10	1100	64,0	16	1760	102,4	185	125	50	45	14	M 8	M 20	69,5	121	160	12
LBDF 90	110 - 115	0,25	6	840	45,6	10	1400	76,0	16	2240	121,6	185	125	60	45	14	M 8	M 20	70	120,5	160	12
	115 - 120	0,25	6	840	43,2	10	1400	72,0	16	2240	115,2	185	125	60	45	14	M 8	M 20	70	120,5	160	12
LBDF 100	120 - 125	0,25	6	1080	51,0	10	1800	85,0	16	2880	136,0	200	125	60	45	14	M 8	M 20	66	124	175	12
	125 - 130	0,25	6	1080	48,6	10	1800	81,0	16	2880	129,6	200	125	60	45	14	M 8	M 20	66	124,5	175	12
	130 - 140	0,35	6,3	950	43,9	10	1520	69,7	20	3040	139,4	200	125	60	45	14	M 8	M 20	66	126,5	175	12

* Clamping diameter from > up to ≤ adjustable to two places after the decimal point • ** of the clamping diameter of the Clamping Element.

¹⁾ A number of different shoulder rings are available for sizes LBDF 15 D = 22 - 27. Consequently, when using Bonded Disc Pack widths of Lb3 dimension Has is reduced by 2,5 mm.

²⁾ A number of different shoulder rings are available for sizes LBDF 15 and LBDF 50, regardless of clamping diameter. Consequently, when using Bonded Disc Pack widths of Lb2 and Lb3, dimension Has is reduced by 2,5 mm with LBDF 15 and by 2 mm with LBDF 50.

Key

- D = Achievable clamping diameter
- Δ D = Maximum diameter change of the clamping diameter of the Clamping Element
- Lb = Bonded disc pack width
- M = Max. transmissible torque
- Fm = Required actuating force for component clamping with pull-back action for max. transmissible torque

Example for ordering

Please indicate the size of the Clamping Fixture and the clamping diameter of your component, including component tolerance, and the desired bonded disc pack width in your order:

Size: LBDF 11
 Clamping diameter: 21,47 mm
 Component tolerance: H7
 Bonded disc pack width: 4 mm

➔ LBDF 11-21,47H7-4

for setup of Bonded Disc Pack Flange Mandrels LBDF to different clamping diameters within a given size and high true running accuracy

Installation situations

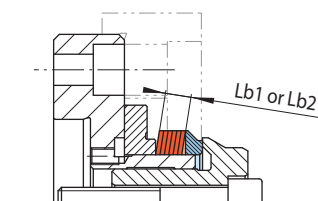
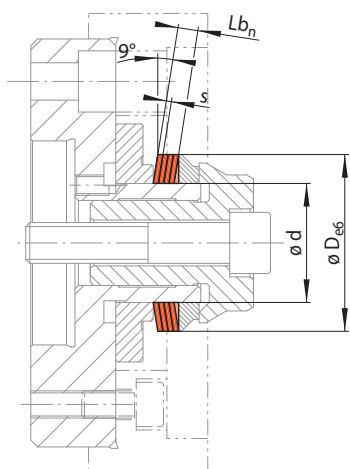

Bonded disc pack widths Lb1 and Lb2

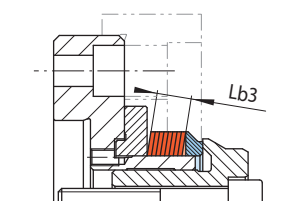

Bonded disc pack width Lb3

28-1

28-2

Size LBD ... ¹⁾	Clamping Discs LBD							Bonded Disc Packs LBD														
	d	D*	ΔD	s	M ₁	Fm ₁	Fo ₁	Art.-No.	Bonded disc pack width Lb1				Bonded disc pack width Lb2				Bonded disc pack width Lb3					
									Lb1	M _n	Fm _n	Fo _n	Art.-No.	Lb2	M _n	Fm _n	Fo _n	Art.-No.	Lb3	M _n	Fm _n	Fo _n
mm	mm	mm	mm	Nm	N	N	1001-	mm	Nm	N	N	3021-	mm	Nm	N	N	3021-	mm	Nm	N	N	3021-
11	18 - 22	0,10	0,5	0,9	380	260	011001	4	7	3100	2100	011001	6	11	4700	3200	011002	8	15	6300	4300	011003
15	22 - 27	0,10	0,5	1,8	560	390	015001	4	15	4500	3200	015001	6	22	6800	4800	015002	8	29	9100	6400	015003
	27 - 32	0,15	0,75	2,7	870	630	015004	6	22	7000	5100	015004	9	33	10500	7700	015005	12	40	14000	10300	015006
20	32 - 37	0,15	0,75	4,9	1200	890	020001	6	39	9600	7200	020001	9	50	14400	10800	020002	12	60	19200	14400	020003
	37 - 42	0,15	0,75	4,7	1050	730	020004	6	38	8400	5900	020004	9	50	12600	8900	020005	12	60	16800	11900	020006
25	37 - 42	0,15	0,75	7,9	1500	1100	025001	6	60	12000	8800	025001	9	90	18000	13200	025002	12	120	24000	17600	025003
	42 - 47	0,15	0,75	7,5	1350	930	025004	6	60	10800	7500	025004	9	90	16200	11300	025005	12	120	21600	15100	025006
30	42 - 47	0,15	0,75	11	1800	1300	030001	6	80	14400	10400	030001	9	130	21600	15600	030002	12	170	28800	20800	030003
	47 - 52	0,15	0,75	10	1600	1100	030004	6	80	12800	8800	030004	9	120	19200	13200	030005	12	160	25600	17600	030006
35	47 - 52	0,15	0,75	16	2150	1550	035001	6	120	17200	12400	035001	9	190	25800	18600	035002	12	250	34400	24800	035003
	52 - 57	0,15	0,75	15	1950	1350	035004	6	120	15600	10800	035004	9	180	23400	16200	035005	12	240	31200	21600	035006
40	52 - 57	0,15	0,75	21	2450	1750	040001	6	160	19600	14000	040001	9	250	29400	21000	040002	12	330	39200	28000	040003
	57 - 62	0,15	0,75	20	2300	1550	040004	6	160	18400	12400	040004	9	240	27600	18600	040005	12	320	36800	24800	040006
45	57 - 62	0,15	0,75	27	2800	2000	045001	6	210	22400	16000	045001	9	320	33600	24000	045002	12	420	44800	32000	045003
	62 - 67	0,15	0,75	26	2600	1600	045004	6	200	20800	12800	045004	9	310	31200	19200	045005	12	410	41600	25600	045006
50	67 - 70	0,15	0,75	32	2900	2000	050004	6	250	23200	16000	050004	9	380	34800	24000	050005	12	500	46400	32000	050006
	70 - 75	0,25	1,0	43	4000	2900	050007	6	250	24000	17400	050007	10	430	40000	29000	050008	16	680	64000	46400	050009
	75 - 80	0,25	1,0	42	3800	2600	050010	6	250	22800	15600	050010	10	420	38000	26000	050011	16	670	60800	41600	050012

¹⁾ Intermediate sizes on request

* Clamping diameter from > up to ≤ adjustable to two places after the decimal point

for setup of Bonded Disc Pack Flange Mandrels LBDF to different clamping diameters within a given size and high true running accuracy

Installation situations

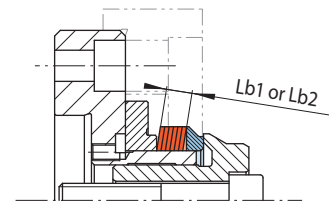
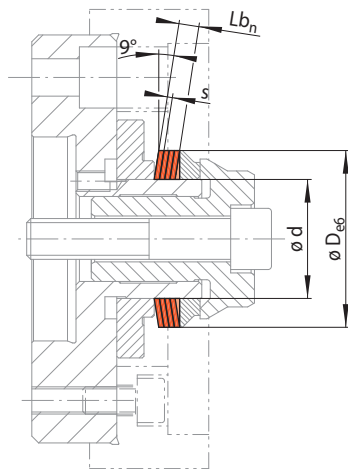

Bonded disc pack widths Lb1 and Lb2

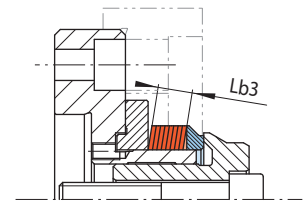

Bonded disc pack width Lb3

29-1

29-2

Size LBD ... ¹⁾	Clamping Discs LBD							Bonded Disc Packs LBD														
	d	D*	ΔD	s	M ₁	Fm ₁	Fo ₁	Art.-No.	Bonded disc pack width Lb1				Bonded disc pack width Lb2				Bonded disc pack width Lb3					
									Lb1	M _n	Fm _n	Fo _n	Art.-No.	Lb2	M _n	Fm _n	Fo _n	Art.-No.	Lb3	M _n	Fm _n	Fo _n
mm	mm	mm	mm	Nm	N	N	1001-	mm	Nm	N	N	3021-	mm	Nm	N	N	3021-	mm	Nm	N	N	3021-
60	80 - 85	0,25	1,0	63	4900	3500	060001	6	370	29400	21000	060001	10	630	49000	35000	060002	16	1000	78400	56000	060003
	85 - 90	0,25	1,0	62	4600	3200	060004	6	370	27600	19200	060004	10	620	46000	32000	060005	16	990	73600	51200	060006
70	90 - 95	0,25	1,0	86	5800	4100	070001	6	510	34800	24600	070001	10	860	58000	41000	070002	16	1370	92800	65600	070003
	95 - 100	0,25	1,0	85	5500	3800	070004	6	510	33000	22800	070004	10	850	55000	38000	070005	16	1360	88000	60800	070006
80	100 - 105	0,25	1,0	110	6600	4700	080001	6	660	39600	28200	080001	10	1100	66000	47000	080002	16	1760	105600	75200	080003
	105 - 110	0,25	1,0	110	6400	4400	080004	6	660	38400	26400	080004	10	1100	64000	44000	080005	16	1760	102400	70400	080006
90	110 - 115	0,25	1,0	140	7600	5400	090001	6	840	45600	32400	090001	10	1400	76000	54000	090002	16	2240	121600	86400	090003
	115 - 120	0,25	1,0	140	7200	5000	090004	6	840	43200	30000	090004	10	1400	72000	50000	090005	16	2240	115200	80000	090006
100	120 - 125	0,25	1,0	180	8500	6000	100001	6	1080	51000	36000	100001	10	1800	85000	60000	100002	16	2880	136000	96000	100003
	125 - 130	0,25	1,0	180	8100	5600	100004	6	1080	48600	33600	100004	10	1800	81000	56000	100005	16	2880	129600	89600	100006
	130 - 140	0,35	1,25	190	8700	6200	100007	6,3	950	43900	31300	100007	10	1520	69700	49700	100008	20	3040	139400	99400	100009
115	140 - 150	0,35	1,25	260	10600	7700	115001	6,3	1310	53500	38900	115001	10	2080	85000	61800	115002	20	4160	170000	123600	115003
	150 - 160	0,35	1,25	260	10000	7000	115004	6,3	1310	50400	35300	115004	10	2080	80000	56100	115005	20	4160	160000	112200	115006
135	160 - 170	0,35	1,25	370	12800	9300	135001	6,3	1860	64600	46900	135001	10	2960	102600	74500	135002	20	5920	205200	149000	135003
	170 - 180	0,35	1,25	370	12000	8400	135004	6,3	1860	60500	42400	135004	10	2960	96100	67400	135005	20	5920	192200	134800	135006
155	180 - 190	0,35	1,25	500	14900	10700	155001	6,3	2520	75100	54000	155001	10	4000	119300	85800	155002	20	8000	238600	171600	155003
	190 - 200	0,35	1,25	500	14000	9700	155004	6,3	2520	70600	48900	155004	10	4000	112100	77700	155005	20	8000	224200	155400	155006

¹⁾ Intermediate sizes on request

* Clamping diameter from > up to ≤ adjustable to two places after the decimal point

Key

d = Seating diameter

D = Achievable clamping diameter

ΔD = Maximum diameter change of the clamping diameter of the Clamping Element

s = Clamping disc thickness

n = Number of Clamping Discs (max. 16)

Lb_n = s · n

= Bonded disc pack width

$$M_n = M_1 \cdot n$$

= Max. transmissible torque

$$Fm_n = Fm_1 \cdot n$$

= Required actuating force for component clamping with pull-back action for max. transmissible torque

$$Fo_n = Fo_1 \cdot n$$

= Required actuating force for component clamping without pull-back action for max. transmissible torque

Example for ordering

Please indicate the size of the Clamping Element, the clamping diameter of your component, including component tolerance, and the desired bonded disc pack width in your order:

Size: LBD 11
Clamping diameter: 21,47 mm
Component tolerance: H7
Bonded disc pack width: 4 mm

➔ LBD 11-21,47 H7-4

for setup of Bonded Disc Pack Flange Mandrels LIDF to different clamping diameters within a given size with large component tolerances, high true running accuracy and high clearance

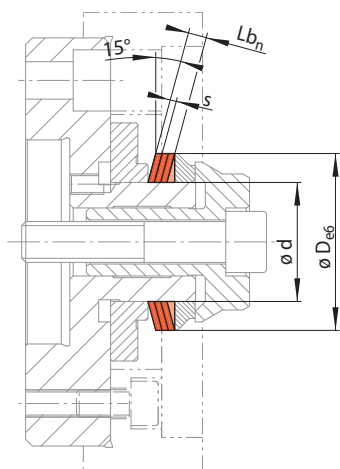

Key

- d = Seating diameter
- D = Achievable clamping diameter
- ΔD = Maximum diameter change of the clamping diameter of the Clamping Element
- s = Clamping disc thickness
- n = Number of Clamping Discs (max. 16)
- $Lb_n = s \cdot n$
= Bonded disc pack width
- $M_n = M_1 \cdot n$
= Max. transmissible torque
- $Fm_n = Fm_1 \cdot n$
= Required actuating force for component clamping with pull-back action
- $Fo_n = Fo_1 \cdot n$
= Required actuating force for component clamping without pull-back action

Installation situations

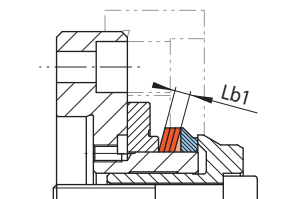

Bonded disc pack widths Lb1

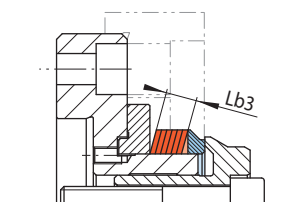

Bonded disc pack width Lb3

30-1

30-2

Size LID ...	Clamping Discs LID							Bonded Disc Packs LID										
	d	D*	ΔD	s	M_1	Fm_1	Fo_1	Art.-No.	Bonded disc pack width Lb1					Bonded disc pack width Lb3				
									Lb1	M_n	Fm_n	Fo_n	Art.-No.	Lb3	M_n	Fm_n	Fo_n	Art.-No.
mm	mm	mm	mm	Nm	N	N	1003-	mm	Nm	N	N	3023-	mm	Nm	N	N	3023-	
15	32 - 37	0,7	0,75	2,5	1000	830	015002	6	20	8000	6640	015006	12	40	16000	13280	015007	
20	37 - 42	0,7	0,75	4,5	1400	1150	020002	6	36	11200	9200	020004	12	72	22400	18400	020005	
25	42 - 47	0,7	0,75	7,5	1850	1500	025002	6	60	14800	12000	025003	12	120	29600	24000	025004	
30	47 - 52	0,7	0,75	10	2150	1750	030002	6	80	17200	14000	030006	12	160	34400	28000	030007	
35	52 - 57	0,7	0,75	14	2500	2000	035002	6	112	20000	16000	035006	12	224	40000	32000	035007	
40	57 - 62	0,7	0,75	19	2900	2350	040002	6	152	23200	18800	040008	12	304	26400	37600	040009	
45	62 - 67	0,7	0,75	25	3350	2700	045002	6	200	26800	21600	045004	12	400	53600	43200	045005	
50	67 - 70	0,7	0,75	32	3800	3050	050004	6	256	30400	24400	050012	12	512	60800	48800	050013	
	70 - 75	0,8	1,0	42	5250	4300	050005	8	336	42000	34400	050014	16	672	84000	68800	050015	
	75 - 80	0,8	1,0	41	4900	4000	050006	8	328	39200	32000	050016	16	656	78400	64000	050017	
60	80 - 85	0,8	1,0	62	6350	5200	060003	8	496	50800	41600	060005	16	992	101600	83200	060006	
	85 - 90	0,8	1,0	60	6000	4850	060004	8	480	48000	38800	060007	16	960	96000	77600	060008	
70	90 - 95	0,8	1,0	85	7500	6150	070003	8	680	60000	49200	070005	16	1360	120000	98400	070006	
	95 - 100	0,8	1,0	85	7200	5800	070004	8	680	57600	46400	070007	16	1360	115200	92800	070008	
80	100 - 105	0,8	1,0	110	8600	7100	080003	8	880	68800	56800	080012	16	1760	137600	113600	080013	
	105 - 110	0,8	1,0	110	8350	6800	080004	8	880	66800	54400	080014	16	1760	133600	108800	080015	
90	110 - 115	0,8	1,0	140	9850	8150	090003	8	1120	78800	65200	090010	16	2240	157600	130400	090011	
	115 - 120	0,8	1,0	140	9500	7700	090004	8	1120	76000	61600	090012	16	2240	152000	123200	090013	
100	120 - 125	0,8	1,0	160	10000	8250	100004	8	1280	80000	66000	100007	16	2560	160000	132000	100008	
	125 - 130	0,8	1,0	175	10600	8600	100005	8	1400	84800	68800	100009	16	2800	169600	137600	100010	
	130 - 140	1,0	1,25	190	11500	9400	100006	10	1520	92000	75200	100011	20	3040	184000	150400	100012	
115	140 - 150	1,0	1,25	255	13900	11500	115002	10	2040	111200	92000	115003	20	4080	222400	184000	115004	
125	150 - 160	1,0	1,25	310	15600	12900	125002	10	2480	124800	103200	125004	20	4960	249600	206400	125005	
135	160 - 170	1,0	1,25	365	16800	13900	135002	10	2920	134400	111200	135003	20	5840	268800	222400	135004	
145	170 - 180	1,0	1,25	430	18500	15300	145002	10	3440	148000	122400	145005	20	6880	296000	244800	145006	
155	180 - 190	1,0	1,25	490	19700	16200	155003	10	3920	157600	129600	155005	20	7840	315200	259200	155006	
	190 - 200	1,0	1,25	475	18000	14600	155004	10	3800	144000	116900	155007	20	7600	288000	233600	155008	

* Clamping diameter from > up to ≤ adjustable to two places after the decimal point

The Bonded Disc Packs LID have a larger taper angle than the Bonded Disc Packs LBD. This makes it possible to clamp larger component tolerances up to IT14 securely. The achievable true running accuracy is ≤ 0,015 mm. Bonded Disc Packs LID can limited be used in Bonded Disc Pack Flange Mandrels. We request that you contact us.

Example for ordering

Please indicate the size of the Clamping Element, the clamping diameter of your component, including component tolerance, and the desired bonded disc pack width in your order:

Size: LID 15
 Clamping diameter: 35,47 mm
 Component tolerance: H7
 Bonded disc pack width: 6 mm
 ➔ LID 15-35,47H7-6

Thrust ring

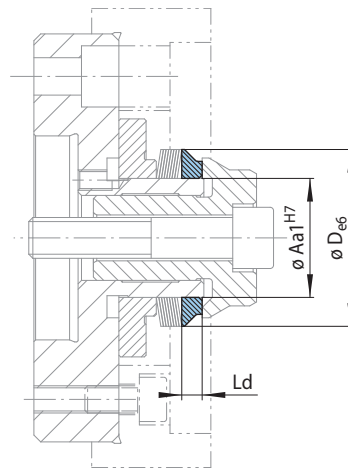

31-1

for size	Aa1	D*	Ld	Art-No.
	mm	mm	mm	1116-
LBDF 11	11	18 - 22	5	011001
LBDF 15	15	22 - 27	5	015001
	15	27 - 32	5	015002
	15	32 - 37	5	015003
LBDF 20	20	32 - 37	5	020001
	20	37 - 42	5	020002
LBDF 25	25	37 - 42	5	025001
	25	42 - 47	5	025002
LBDF 30	30	42 - 47	6	030001
	30	47 - 52	6	030002
LBDF 35	35	47 - 52	6	035001
	35	52 - 57	6	035002
LBDF 40	40	52 - 57	6	040001
	40	57 - 62	6	040002
LBDF 45	45	57 - 62	6	045001
	45	62 - 67	6	045002
LBDF 50	50	67 - 70	6	050002
	50	70 - 75	6	050003
	50	75 - 80	6	050004
LBDF 60	60	80 - 85	6	060001
	60	85 - 90	6	060002
LBDF 70	70	90 - 95	6	070001
	70	95 - 100	6	070002
LBDF 80	80	100 - 105	8	080001
	80	105 - 110	8	080002
LBDF 90	90	110 - 115	8	090001
	90	115 - 120	8	090002
LBDF 100	100	120 - 125	8	100001
	100	125 - 130	8	100002
	100	130 - 140	8	100004

* Clamping diameter from > up to ≤ adjustable to two places after the decimal point • $\varnothing D_{e6}$ for thrust ring and disc / bonded disc pack has to be manufactured in same nominal dimensions.

Assembly group for hand clamping (optional)

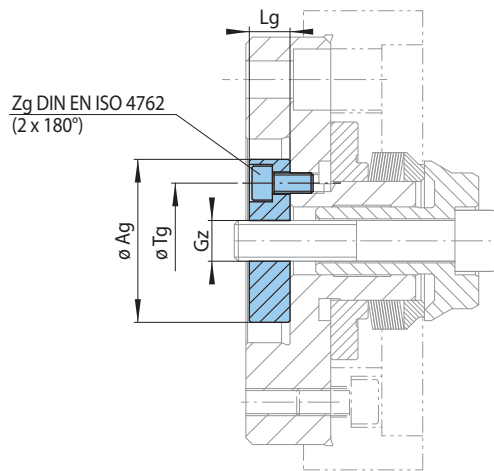

32-1

for size	Max. permissible tightening torque M_A for bonded disc pack width			Ag mm	Gz	Lg mm	Tg mm	Zg	Art.-No. 3128-
	Lb1	Lb2	Lb3						
	Nm	Nm	Nm						
LBDF 11	2,5	3,9	5,2	36	M 5	8	24	M 5	036900
LBDF 15	4,5	6,7	9,1	36	M 6	8	24	M 5	036901
	6,9	10,4	14,0	36	M 6	8	24	M 5	036901
LBDF 20	12,7	19,0	25,4	36	M 8	8	24	M 5	036902
	11,1	16,7	22,2	36	M 8	8	24	M 5	036902
LBDF 25	19,5	29,2	38,9	43	M 10	10	30	M 6	043900
	17,5	26,3	35,0	43	M 10	10	30	M 6	043900
LBDF 30	28,1	42,2	56,3	48	M 12	12	34	M 6	048900
	25,0	37,5	50,0	48	M 12	12	34	M 6	048900
LBDF 35	33,6	50,4	67,2	48	M 12	12	34	M 6	048900
	30,5	45,7	61,0	48	M 12	12	34	M 6	048900
LBDF 40	38,3	57,4	76,6	48	M 12	12	34	M 6	048900
	36,0	53,9	71,9	48	M 12	12	34	M 6	048900
LBDF 45	57,0	85,6	114,1	58	M 16	15	44	M 6	058900
	53,0	79,5	105,9	58	M 16	15	44	M 6	058900
LBDF 50	59,1	88,6	118,2	58	M 16	15	44	M 6	058900
	61,1	101,9	163,0	58	M 16	15	44	M 6	058900
	58,1	96,8	154,8	58	M 16	15	44	M 6	058900
LBDF 60	74,9	124,8	199,6	68	M 16	15	54	M 6	068900
	70,3	117,1	187,4	68	M 16	15	54	M 6	068900
LBDF 70	88,6	147,7	235,9	68	M 16	15	54	M 6	068900
	84,0	140,0	223,7	68	M 16	15	54	M 6	068900
LBDF 80	126,4	210,7	337,1	89,5	M 20	20	72	M 8	089900
	122,6	204,3	326,9	89,5	M 20	20	72	M 8	089900
LBDF 90	145,6	242,6	388,2	89,5	M 20	20	72	M 8	089900
	137,9	229,8	367,8	89,5	M 20	20	72	M 8	089900
LBDF 100	162,8	271,3	432,9	89,5	M 20	20	72	M 8	089900
	155,2	258,6	412,5	89,5	M 20	20	72	M 8	089900
	140,1	222,5	443,7	89,5	M 20	20	72	M 8	089900

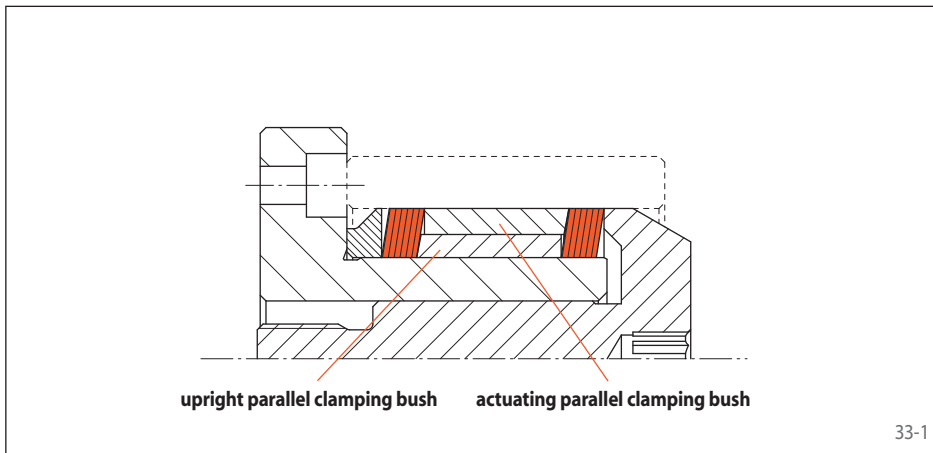

Parallel Bonded Disc Pack Flange Mandrel

to transmit high operating torque and for clamping in long bores with tolerance $\leq IT7$.

Functional principle:

The upright parallel clamping bush remains stationary and retains the Bonded Disc Pack in position, the actuating bush transmits the actuating force by axial movement.

Precondition:

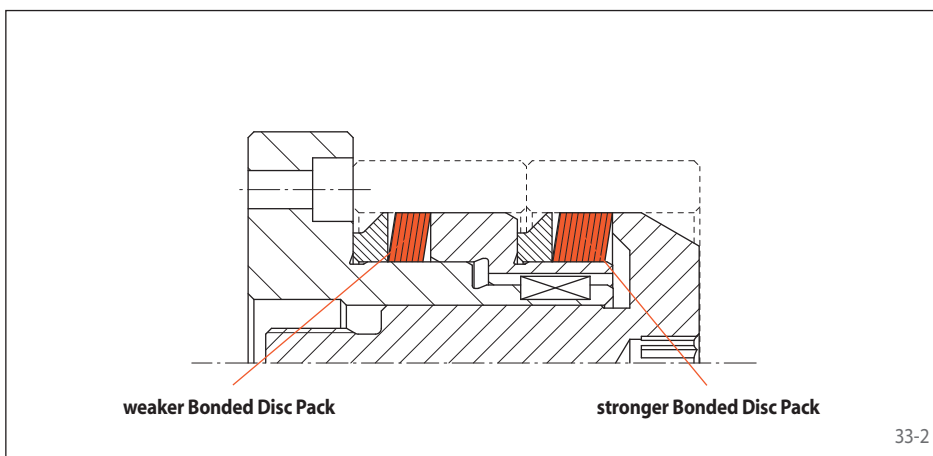

Series Bonded Disc Pack Flange Mandrel

for clamping two identical components.

Functional principle:

The weaker Bonded Disc Pack is raised first. It clamps the first component. Then the stronger Bonded Disc Pack is raised and clamps the second component. Alignment with the first component is achieved through pull-back action.

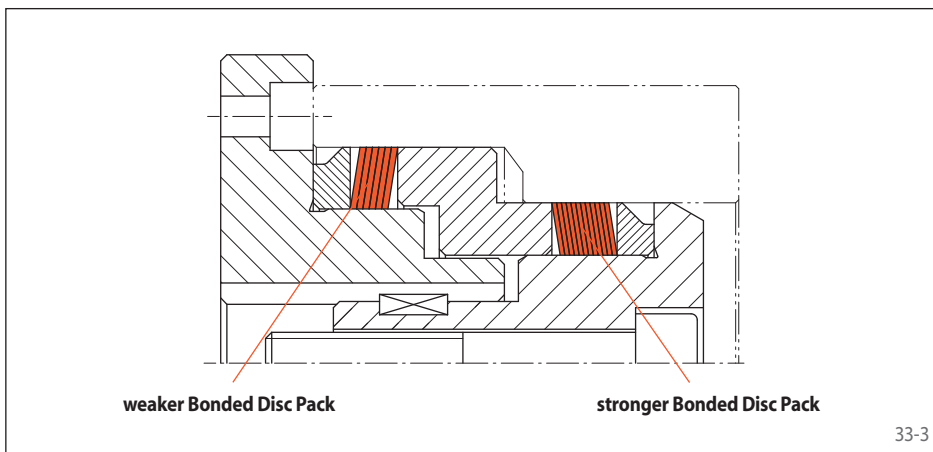

Direct Differential Bonded Disc Pack Flange Mandrel

for clamping components with two different clamping diameters.

Functional principle:

The weaker Bonded Disc Pack is raised first. It centres the component and presses it against the backstop surface for alignment. Only then does the stronger Bonded Disc Pack centre the component at the second clamping point.

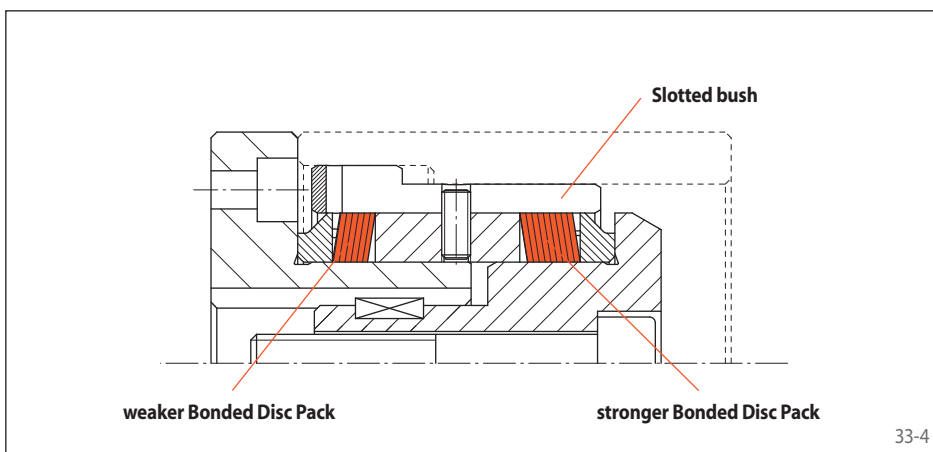

Indirect Differential Bonded Disc Pack Flange Mandrel

for clamping components with two different clamping diameters on sensitive surface.

Functional principle:

The weaker Bonded Disc Pack is raised first. It centres the component and presses it against the backstop surface for alignment. Only then does the stronger Bonded Disc Pack centre the component. By changing the slotted bush different components can be clamped.

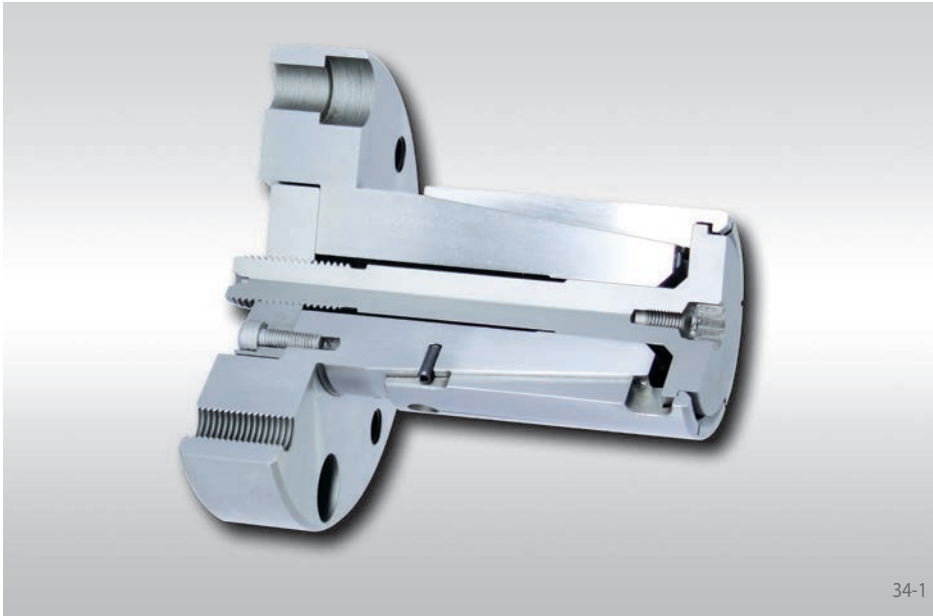

34-1

Features

- For clamping diameters from 11,9 mm to 132 mm
- High true running accuracy $\leq 0,01$ mm
- Permissible component tolerance up to IT15
- Pull-back against external backstop surface or external backstop ring by the customer
- For thin-walled or solid components
- Hand clamping optional possible

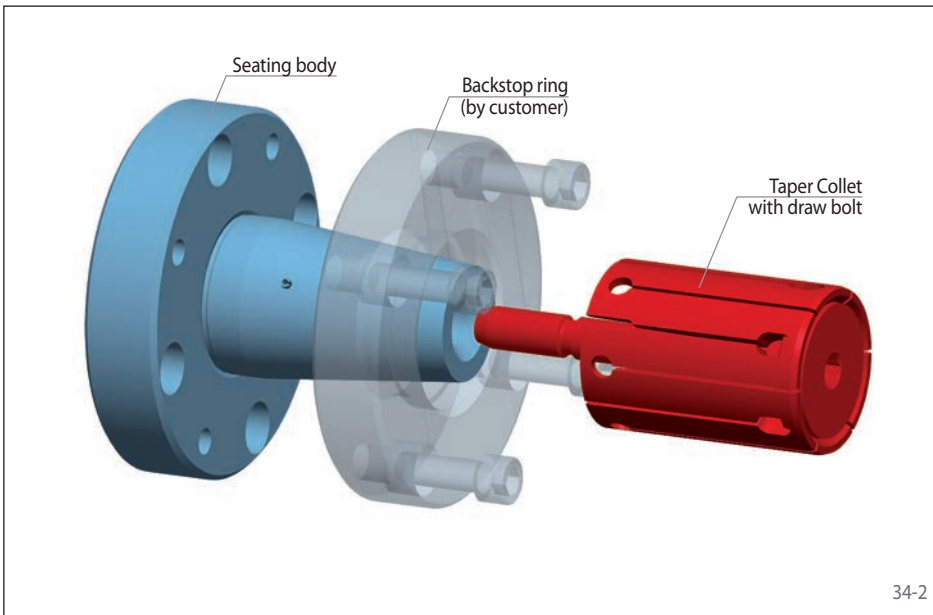

34-2

Configuration

The Taper Collet Flange Mandrel consists of a seating body and a Taper Collet with draw bolt. Taper Collets with hexagon head or pre-centering and a plate with threaded bore are optionally available. The Taper Collet Flange Mandrel is attached to the machine with the seating body. The Clamping Fixture is actuated by the draw bolt, which is connected to the machine power actuating unit.

Intermediate Flanges and Spring Force Actuators are shown starting on page 58.

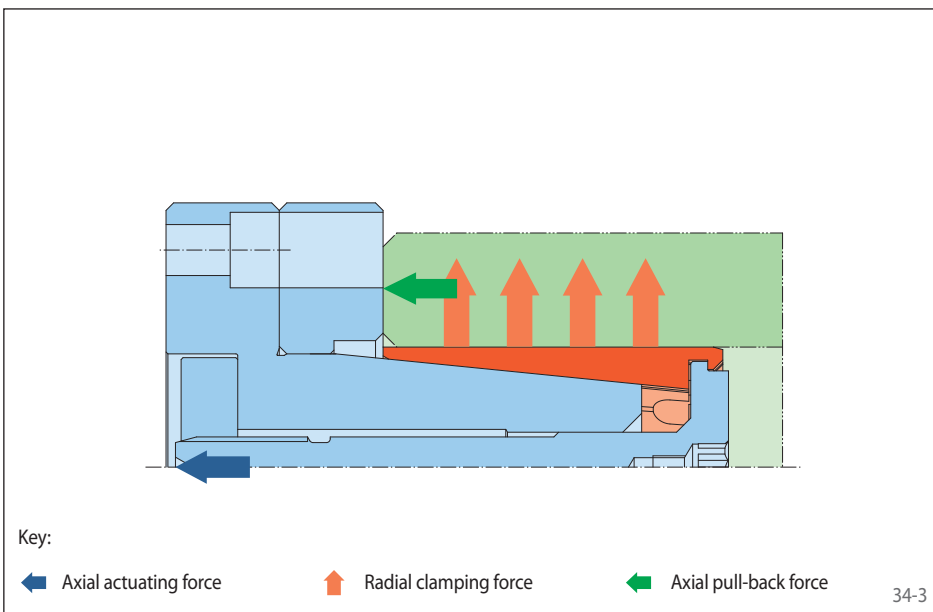

34-3

Clamping principle

For clamping, the Taper Collet is pulled against the seating body and radially expands over the cone of basebody. The component is centred, pressed against the backstop and aligned flush.

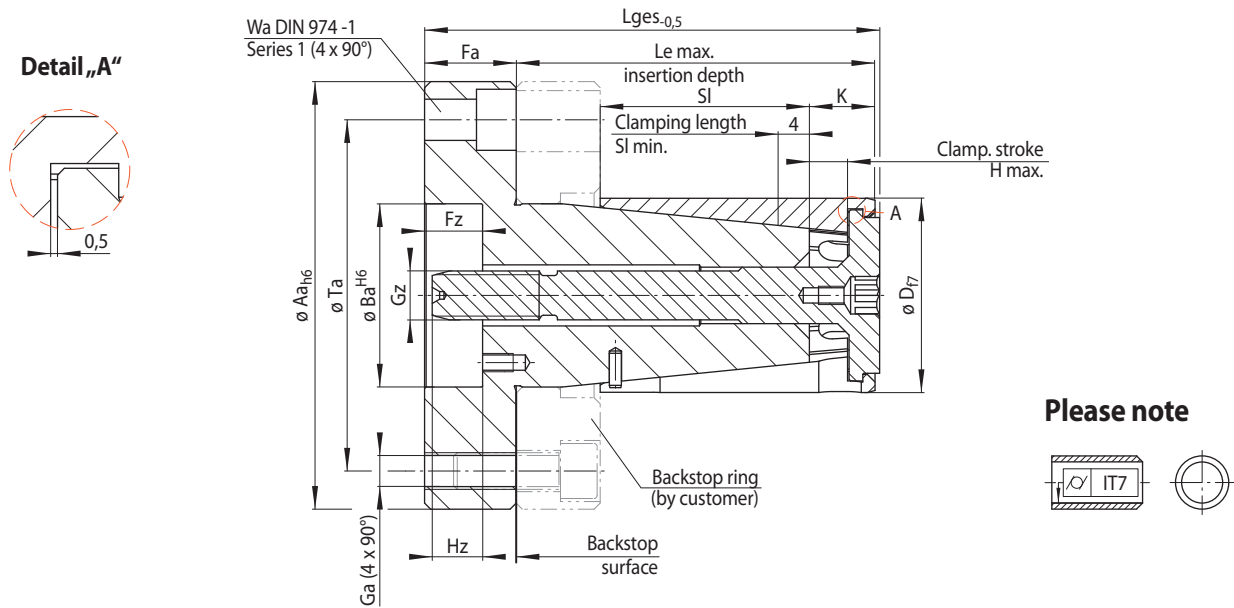

35-1

Size	Clamping range D ¹⁾ mm	Maximum diameter change* ΔD mm	Max. transmissible torque** M Nm	Max. actuating force** F N	Aa mm	Ba mm	Fa mm	Fz mm	Ga mm	Gz mm	H max. mm	Hz mm	K mm	Le max. mm	Lges mm	SI mm	Ta mm	Wa mm
BKDF 6	11,90 - 15,00	0,6	11	5000	70	37	20	9	M 8	M 5	4,1	18,4	8,1	31,9	53,1	14,9	50	8
BKDF 7	14,70 - 20,90	1,2	13	5000	70	37	20	9	M 8	M 5	6,9	18,4	10,9	46,9	69,6	24,1	50	8
BKDF 12	20,70 - 27,90	1,2	44	12000	70	37	20	9	M 8	M 8	6,95	16,35	11,45	61,45	84,65	33,55	50	8
BKDF 18	27,70 - 32,80	1,2	58	12000	70	37	20	9	M 8	M 8	7,0	16,4	11,5	60,5	82,0	33,5	50	8
BKDF 19	32,60 - 42,80	1,2	114	20000	90	50	30	14	M 8	M 12	7,0	18,3	13,0	82,0	113,5	52,0	70	8
BKDF 27	42,60 - 51,80	1,2	147	20000	90	50	30	14	M 8	M 12	7,0	18,3	13,0	82,0	113,5	52,0	70	8
BKDF 32	51,60 - 64,00	2,4	273	30000	120	60	30	19	M 10	M 16	13,0	16,5	21,5	117,5	149,0	68,5	95	10
BKDF 43	63,60 - 72,00	2,4	333	30000	140	60	30	19	M 12	M 16	13,0	16,5	21,5	117,5	149,0	68,5	115	12
BKDF 44	71,60 - 82,00	2,4	373	30000	140	60	30	19	M 12	M 16	13,0	16,5	21,5	147,5	179,0	98,5	115	12
BKDF 54	81,60 - 132,00	2,4	424	30000	140	60	30	19	M 12	M 16	13,05	16,45	21,55	147,55	179,05	98,45	115	12

¹⁾ Please note the standard clamping ranges according to the tables on the next pages „Clamping Elements Taper Collets“.

* of the clamping diameter of the Clamping Element.

** for clamping with pull-back action.

Example for ordering

Please indicate the size of the Clamping Fixture and the clamping range of the requested Taper Collet, in your order:

Size: BKDF 27
 Clamping range: 46,60 - 47,80 mm
 ➔ BKDF 27-46,60-47,80

Insertion depth

The minimum insertion depth $Le_{min.}$ is derived according to the following formula from the component chamfer length Lf and dimension K :

$$Le_{min.} = K + Lf + 4 \text{ mm (SI}_{min.})$$

for setup of Taper Collet Flange Mandrels BKDF
to different clamping diameters within a given size

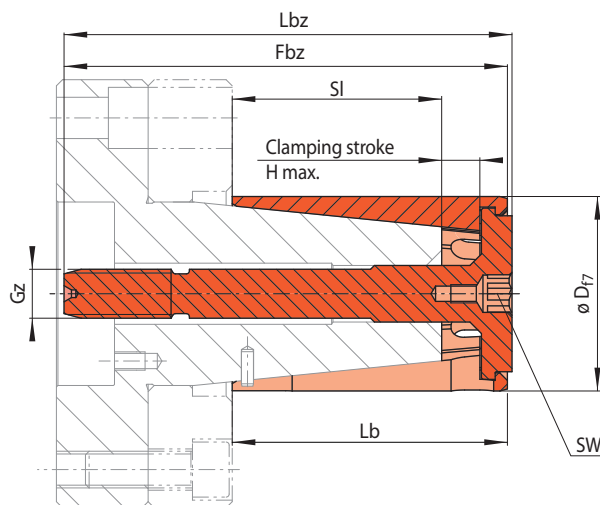

Example for ordering

Please indicate the size of the Clamping Element and the clamping range of the requested Taper Collet, in your order:

Size: **BKD 27**
Clamping range: **46,60 - 47,80 mm**
➔ **BKD 27-46,60-47,80**

36-1

Size BKD ...	Clamping range ¹⁾		Max. transmissible torque*	Max. actuating force*	Tightening torque for hand clamping*	Fbz	Gz	H max.	Lb	Lbz	SI	SW	Art.-No.
	D mm	M Nm											
6**	11,90 - 12,50	11	5000	5	61,3	M 5	4,1	23	62,5	14,9	3	006103-011.90	
	12,40 - 13,00	11	5000	5	61,3	M 5	4,1	23	62,5	14,9	3	006103-012.40	
	12,90 - 13,50	11	5000	5	61,3	M 5	4,1	23	62,5	14,9	3	006103-012.90	
	13,40 - 14,00	11	5000	5	61,3	M 5	4,1	23	62,5	14,9	3	006103-013.40	
	13,90 - 14,50	11	5000	5	61,3	M 5	4,1	23	62,5	14,9	3	006103-013.90	
	14,40 - 15,00	11	5000	5	61,3	M 5	4,1	23	62,5	14,9	3	006103-014.40	
7	14,70 - 15,90	13	5000	5	76,3	M 5	6,9	35	79,0	24,1	3	007106-014.70	
	15,70 - 16,90	13	5000	5	76,3	M 5	6,9	35	79,0	24,1	3	007106-015.70	
	16,70 - 17,90	13	5000	5	76,3	M 5	6,9	35	79,0	24,1	3	007106-016.70	
	17,70 - 18,90	13	5000	5	76,3	M 5	6,9	35	79,0	24,1	3	007106-017.70	
	18,70 - 19,90	13	5000	5	76,3	M 5	6,9	35	79,0	24,1	3	007106-018.70	
	19,70 - 20,90	13	5000	5	76,3	M 5	6,9	35	79,0	24,1	3	007106-019.70	
12	20,70 - 21,90	44	12000	20	88,8	M 8	6,95	45	92,0	33,55	5	012165-020.70	
	21,70 - 22,90	44	12000	20	88,8	M 8	6,95	45	92,0	33,55	5	012165-021.70	
	22,70 - 23,90	44	12000	20	88,8	M 8	6,95	45	92,0	33,55	5	012165-022.70	
	23,70 - 24,90	44	12000	20	88,8	M 8	6,95	45	92,0	33,55	5	012165-023.70	
	24,70 - 25,90	44	12000	20	88,8	M 8	6,95	45	92,0	33,55	5	012165-024.70	
	25,70 - 26,90	44	12000	20	88,8	M 8	6,95	45	92,0	33,55	5	012165-025.70	
	26,70 - 27,90	44	12000	20	88,8	M 8	6,95	45	92,0	33,55	5	012165-026.70	
18	27,70 - 28,90	58	12000	24	87,9	M 8	7,0	45	89,4	33,5	5	018179-027.70	
	28,70 - 29,90	58	12000	24	87,9	M 8	7,0	45	89,4	33,5	5	018179-028.70	
	29,70 - 30,90	58	12000	24	87,9	M 8	7,0	45	89,4	33,5	5	018179-029.70	
	30,60 - 31,80	58	12000	24	87,9	M 8	7,0	45	89,4	33,5	5	018179-030.60	
	31,60 - 32,80	58	12000	24	87,9	M 8	7,0	45	89,4	33,5	5	018179-031.60	
19	32,60 - 33,80	114	20000	51	116,3	M 12	7,0	65	117,8	52,0	8	018180-032.60	
	33,60 - 34,80	114	20000	51	116,3	M 12	7,0	65	117,8	52,0	8	018180-033.60	
	34,60 - 35,80	114	20000	51	116,3	M 12	7,0	65	117,8	52,0	8	018180-034.60	
	35,60 - 36,80	114	20000	51	116,3	M 12	7,0	65	117,8	52,0	8	018180-035.60	
	36,60 - 37,80	114	20000	51	116,3	M 12	7,0	65	117,8	52,0	8	018180-036.60	
	37,60 - 38,80	114	20000	51	116,3	M 12	7,0	65	117,8	52,0	8	018180-037.60	
	38,60 - 39,80	114	20000	51	116,3	M 12	7,0	65	117,8	52,0	8	018180-038.60	
	39,60 - 40,80	114	20000	51	116,3	M 12	7,0	65	117,8	52,0	8	018180-039.60	
	40,60 - 41,80	114	20000	51	116,3	M 12	7,0	65	117,8	52,0	8	018180-040.60	
	41,60 - 42,80	114	20000	51	116,3	M 12	7,0	65	117,8	52,0	8	018180-041.60	
27	42,60 - 43,80	147	20000	62	116,3	M 12	7,0	65	117,8	52,0	8	027108-042.60	
	43,60 - 44,80	147	20000	62	116,3	M 12	7,0	65	117,8	52,0	8	027108-043.60	
	44,60 - 45,80	147	20000	62	116,3	M 12	7,0	65	117,8	52,0	8	027108-044.60	
	45,60 - 46,80	147	20000	62	116,3	M 12	7,0	65	117,8	52,0	8	027108-045.60	
	46,60 - 47,80	147	20000	62	116,3	M 12	7,0	65	117,8	52,0	8	027108-046.60	
	47,60 - 48,80	147	20000	62	116,3	M 12	7,0	65	117,8	52,0	8	027108-047.60	
	48,60 - 49,80	147	20000	62	116,3	M 12	7,0	65	117,8	52,0	8	027108-048.60	
	49,60 - 50,80	147	20000	62	116,3	M 12	7,0	65	117,8	52,0	8	027108-049.60	
	50,60 - 51,80	147	20000	62	116,3	M 12	7,0	65	117,8	52,0	8	027108-050.60	

* for clamping with pull-back action. ** Size BKD 6 without guidance

¹⁾ Other clamping ranges available on short notice by request

for setup of Taper Collet Flange Mandrels BKDF
to different clamping diameters within a given size

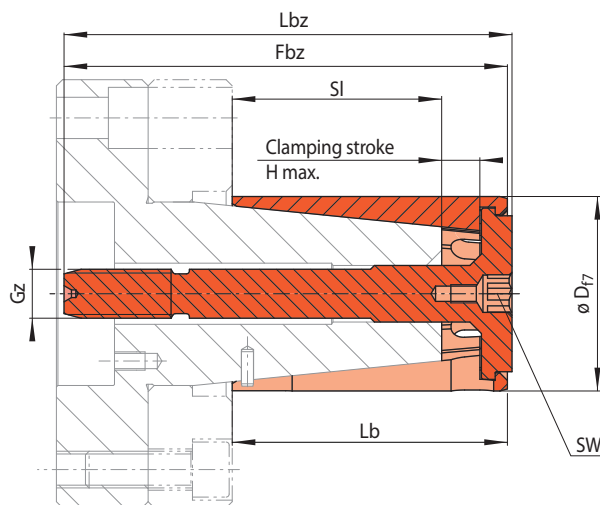

Example for ordering

Please indicate the size of the Clamping Element and the clamping range of the requested Taper Collet, in your order:

Size: BKD 32
Clamping range: 55,60 - 58,00 mm
➔ BKD 32-55,60-58,00

37-1

Size BKD ...	Clamping range ¹⁾	Max. transmissible torque*	Max. actuating force*	Tightening torque for hand clamping*	Fbz	Gz	H max.	Lb	Lbz	SI	SW	Art.-No.
	D mm											
32	51,60 - 54,00	273	30000	113	145	M 16	13,0	90	146,5	68,5	12	032112-051.60
	53,60 - 56,00	273	30000	113	145	M 16	13,0	90	146,5	68,5	12	032112-053.60
	55,60 - 58,00	273	30000	113	145	M 16	13,0	90	146,5	68,5	12	032112-055.60
	57,60 - 60,00	273	30000	113	145	M 16	13,0	90	146,5	68,5	12	032112-057.60
	59,60 - 62,00	273	30000	113	145	M 16	13,0	90	146,5	68,5	12	032112-059.60
43	61,60 - 64,00	273	30000	113	145	M 16	13,0	90	146,5	68,5	12	032112-061.60
	63,60 - 66,00	333	30000	134	145	M 16	13,0	90	146,5	68,5	12	043107-063.60
	65,60 - 68,00	333	30000	134	145	M 16	13,0	90	146,5	68,5	12	043107-065.60
	67,60 - 70,00	333	30000	134	145	M 16	13,0	90	146,5	68,5	12	043107-067.60
44	69,60 - 72,00	333	30000	134	145	M 16	13,0	90	146,5	68,5	12	043107-069.60
	71,60 - 74,00	373	30000	140	175	M 16	13,0	120	176,5	98,5	12	043108-071.60
	73,60 - 76,00	373	30000	140	175	M 16	13,0	120	176,5	98,5	12	043108-073.60
	75,60 - 78,00	373	30000	140	175	M 16	13,0	120	176,5	98,5	12	043108-075.60
54	77,60 - 80,00	373	30000	140	175	M 16	13,0	120	176,5	98,5	12	043108-077.60
	79,60 - 82,00	373	30000	140	175	M 16	13,0	120	176,5	98,5	12	043108-079.60
	81,60 - 84,00	424	30000	159	175	M 16	13,05	120	176,5	98,45	12	054110-081.60
	83,60 - 86,00	424	30000	159	175	M 16	13,05	120	176,5	98,45	12	054110-083.60
	85,60 - 88,00	424	30000	159	175	M 16	13,05	120	176,5	98,45	12	054110-085.60
	87,60 - 90,00	424	30000	159	175	M 16	13,05	120	176,5	98,45	12	054110-087.60
	89,60 - 92,00	424	30000	159	175	M 16	13,05	120	176,5	98,45	12	054110-089.60
	91,60 - 94,00	424	30000	159	175	M 16	13,05	120	176,5	98,45	12	054110-091.60
	93,60 - 96,00	424	30000	159	175	M 16	13,05	120	176,5	98,45	12	054110-093.60
	95,60 - 98,00	424	30000	159	175	M 16	13,05	120	176,5	98,45	12	054110-095.60
	97,60 - 100,00	424	30000	159	175	M 16	13,05	120	176,5	98,45	12	054110-097.60
	99,60 - 102,00	424	30000	159	175	M 16	13,05	120	176,5	98,45	12	054110-099.60
	101,60 - 104,00	424	30000	159	175	M 16	13,05	120	176,5	98,45	12	054111-101.60
	103,60 - 106,00	424	30000	159	175	M 16	13,05	120	176,5	98,45	12	054111-103.60
	105,60 - 108,00	424	30000	159	175	M 16	13,05	120	176,5	98,45	12	054111-105.60
	107,60 - 110,00	424	30000	159	175	M 16	13,05	120	176,5	98,45	12	054111-107.60
	109,60 - 112,00	424	30000	159	175	M 16	13,05	120	176,5	98,45	12	054111-109.60
	111,60 - 114,00	424	30000	159	175	M 16	13,05	120	176,5	98,45	12	054112-111.60
	113,60 - 116,00	424	30000	159	175	M 16	13,05	120	176,5	98,45	12	054112-113.60
	115,60 - 118,00	424	30000	159	175	M 16	13,05	120	176,5	98,45	12	054112-115.60
117,60 - 120,00	424	30000	159	175	M 16	13,05	120	176,5	98,45	12	054112-117.60	
119,60 - 122,00	424	30000	159	175	M 16	13,05	120	176,5	98,45	12	054112-119.60	
121,60 - 124,00	424	30000	159	175	M 16	13,05	120	176,5	98,45	12	054113-121.60	
123,60 - 126,00	424	30000	159	175	M 16	13,05	120	176,5	98,45	12	054113-123.60	
125,60 - 128,00	424	30000	159	175	M 16	13,05	120	176,5	98,45	12	054113-125.60	
127,60 - 130,00	424	30000	159	175	M 16	13,05	120	176,5	98,45	12	054113-127.60	
129,60 - 132,00	424	30000	159	175	M 16	13,05	120	176,5	98,45	12	054113-129.60	

* for clamping with pull-back action.

¹⁾ Other clamping ranges available on short notice by request

Clamping Elements Taper Collets with pre-centring BVD **RINGSPANN®**

for setup of Taper Collet Flange Mandrels BKDF
to different clamping diameters within a given size

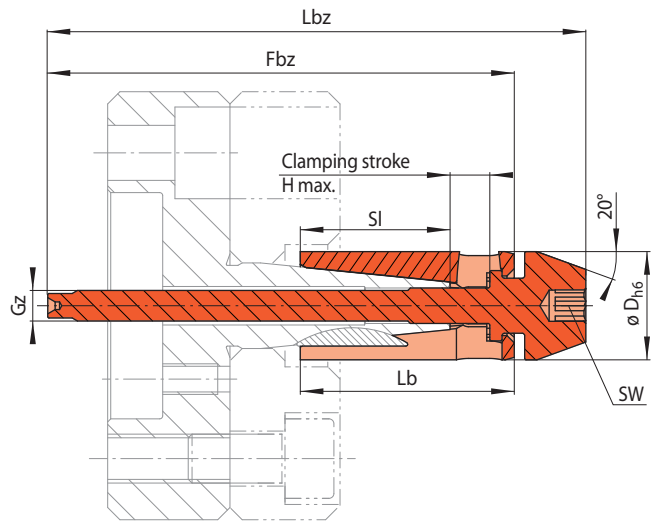

Sizes BVD 6 and BVD 7

38-1

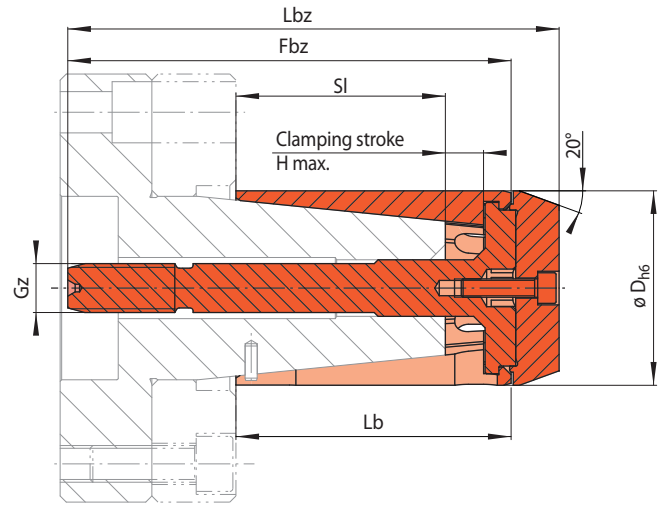

Sizes BVD 12 to BVD 54

38-2

Size BVD ...	Clamping range ¹⁾	Max. transmissible torque*	Max. actuating force*	Tightening torque for hand clamping*	Fbz	Gz	H max.	Lb	Lbz	SI	SW	Art.-No.
6**	11,90 - 12,50	11	5000	5	61,3	M 5	4,1	23	70,5	14,9	5	006400-011.90
	12,40 - 13,00	11	5000	5	61,3	M 5	4,1	23	70,5	14,9	5	006400-012.40
	12,90 - 13,50	11	5000	5	61,3	M 5	4,1	23	70,5	14,9	5	006400-012.90
	13,40 - 14,00	11	5000	5	61,3	M 5	4,1	23	70,5	14,9	5	006400-013.40
	13,90 - 14,50	11	5000	5	61,3	M 5	4,1	23	70,5	14,9	5	006400-013.90
7	14,40 - 15,00	11	5000	5	61,3	M 5	4,1	23	70,5	14,9	5	006400-014.40
	14,70 - 15,90	13	5000	5	76,3	M 5	6,9	35	88,0	24,1	5	007400-014.70
	15,70 - 16,90	13	5000	5	76,3	M 5	6,9	35	88,0	24,1	5	007400-015.70
	16,70 - 17,90	13	5000	5	76,3	M 5	6,9	35	88,0	24,1	5	007400-016.70
	17,70 - 18,90	13	5000	5	76,3	M 5	6,9	35	88,0	24,1	5	007400-017.70
12	18,70 - 19,90	13	5000	5	76,3	M 5	6,9	35	88,0	24,1	5	007400-018.70
	19,70 - 20,90	13	5000	5	76,3	M 5	6,9	35	88,0	24,1	5	007400-019.70
	20,70 - 21,90	44	12000	Power actuating only	88,8	M 8	6,95	45	99,5	33,55	-	012400-020.70
	21,70 - 22,90	44	12000		88,8	M 8	6,95	45	99,5	33,55	-	012400-021.70
	22,70 - 23,90	44	12000		88,8	M 8	6,95	45	99,5	33,55	-	012400-022.70
23,70 - 24,90	44	12000	88,8		M 8	6,95	45	99,5	33,55	-	012400-023.70	
24,70 - 25,90	44	12000	88,8		M 8	6,95	45	99,5	33,55	-	012400-024.70	
18	25,70 - 26,90	44	12000		88,8	M 8	6,95	45	99,5	33,55	-	012400-025.70
	26,70 - 27,90	44	12000		88,8	M 8	6,95	45	99,5	33,55	-	012400-026.70
	27,70 - 28,90	58	12000		87,9	M 8	7,0	45	98,6	33,5	-	018400-027.70
	28,70 - 29,90	58	12000		87,9	M 8	7,0	45	98,6	33,5	-	018400-028.70
	29,70 - 30,90	58	12000		87,9	M 8	7,0	45	98,6	33,5	-	018400-029.70
19	30,60 - 31,80	58	12000		87,9	M 8	7,0	45	98,6	33,5	-	018400-030.60
	31,60 - 32,80	58	12000		87,9	M 8	7,0	45	98,6	33,5	-	018400-031.60
	32,60 - 33,80	114	20000		116,3	M 12	7,0	65	127	52,0	-	019400-032.60
	33,60 - 34,80	114	20000		116,3	M 12	7,0	65	127	52,0	-	019400-033.60
	34,60 - 35,80	114	20000	116,3	M 12	7,0	65	127	52,0	-	019400-034.60	
	35,60 - 36,80	114	20000	116,3	M 12	7,0	65	127	52,0	-	019400-035.60	
	36,60 - 37,80	114	20000	116,3	M 12	7,0	65	127	52,0	-	019400-036.60	
	37,60 - 38,80	114	20000	116,3	M 12	7,0	65	127	52,0	-	019400-037.60	
	38,60 - 39,80	114	20000	116,3	M 12	7,0	65	127	52,0	-	019400-038.60	
	39,60 - 40,80	114	20000	116,3	M 12	7,0	65	127	52,0	-	019400-039.60	
27	40,60 - 41,80	114	20000	116,3	M 12	7,0	65	127	52,0	-	019400-040.60	
	41,60 - 42,80	114	20000	116,3	M 12	7,0	65	127	52,0	-	019400-041.60	
	42,60 - 43,80	147	20000	116,3	M 12	7,0	65	132	52,0	-	027400-042.60	
	43,60 - 44,80	147	20000	116,3	M 12	7,0	65	132	52,0	-	027400-043.60	
	44,60 - 45,80	147	20000	116,3	M 12	7,0	65	132	52,0	-	027400-044.60	
	45,60 - 46,80	147	20000	116,3	M 12	7,0	65	132	52,0	-	027400-045.60	
	46,60 - 47,80	147	20000	116,3	M 12	7,0	65	132	52,0	-	027400-046.60	
	47,60 - 48,80	147	20000	116,3	M 12	7,0	65	132	52,0	-	027400-047.60	
	48,60 - 49,80	147	20000	116,3	M 12	7,0	65	132	52,0	-	027400-048.60	
	49,60 - 50,80	147	20000	116,3	M 12	7,0	65	132	52,0	-	027400-049.60	
50,60 - 51,80	147	20000	116,3	M 12	7,0	65	132	52,0	-	027400-050.60		

* for clamping with pull-back action. ** Size BKD 6 without guidance

¹⁾ Other clamping ranges available on short notice by request

Clamping Elements Taper Collets with pre-centring BVD **RINGSPANN®**

for setup of Taper Collet Flange Mandrels BKDF
to different clamping diameters within a given size

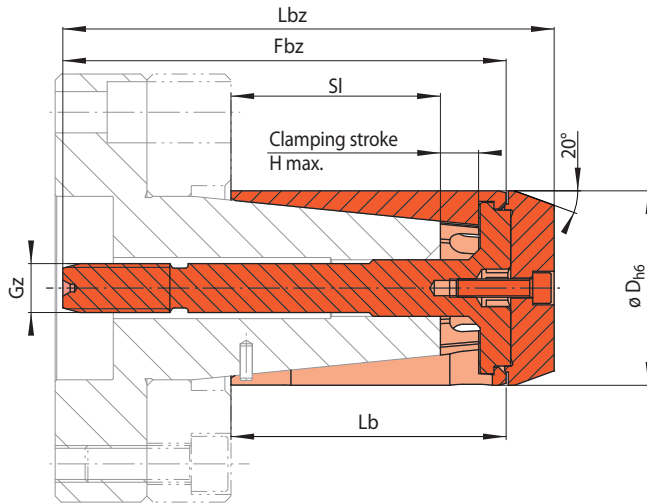

Sizes BVD 12 to BVD 54

39-1

Example for ordering

Please indicate the size of the Clamping Element and the clamping range of the requested Taper Collet, in your order:

Size: BVD 32
Clamping range: 55,60 - 58,00 mm
➔ BVD 32-55,60-58,00

Size BVD ...	Clamping range ¹⁾	Max. transmissible torque* M Nm	Max. actuating force* F N	Fbz mm	Gz	H max. mm	Lb mm	Lbz mm	Sl mm	Art.-No. 3198-
	D mm									
32	51,60 – 54,00	273	30000	145	M 16	13,0	90	160,7	68,5	032400-051.60
	53,60 – 56,00	273	30000	145	M 16	13,0	90	160,7	68,5	032400-053.60
	55,60 – 58,00	273	30000	145	M 16	13,0	90	160,7	68,5	032400-055.60
	57,60 – 60,00	273	30000	145	M 16	13,0	90	160,7	68,5	032400-057.60
	59,60 – 62,00	273	30000	145	M 16	13,0	90	160,7	68,5	032400-059.60
	61,60 – 64,00	273	30000	145	M 16	13,0	90	160,7	68,5	032400-061.60
43	63,60 – 66,00	333	30000	145	M 16	13,0	90	160,7	68,5	043400-063.60
	65,60 – 68,00	333	30000	145	M 16	13,0	90	160,7	68,5	043400-065.60
	67,60 – 70,00	333	30000	145	M 16	13,0	90	160,7	68,5	043400-067.60
	69,60 – 72,00	333	30000	145	M 16	13,0	90	160,7	68,5	043400-069.60
44	71,60 – 74,00	373	30000	175	M 16	13,0	120	190,7	98,5	044400-071.60
	73,60 – 76,00	373	30000	175	M 16	13,0	120	190,7	98,5	044400-073.60
	75,60 – 78,00	373	30000	175	M 16	13,0	120	190,7	98,5	044400-075.60
	77,60 – 80,00	373	30000	175	M 16	13,0	120	190,7	98,5	044400-077.60
	79,60 – 82,00	373	30000	175	M 16	13,0	120	190,7	98,5	044400-079.60
54	81,60 – 84,00	424	30000	175	M 16	13,05	120	195,6	98,45	054400-081.60
	83,60 – 86,00	424	30000	175	M 16	13,05	120	195,6	98,45	054400-083.60
	85,60 – 88,00	424	30000	175	M 16	13,05	120	195,6	98,45	054400-085.60
	87,60 – 90,00	424	30000	175	M 16	13,05	120	195,6	98,45	054400-087.60
	89,60 – 92,00	424	30000	175	M 16	13,05	120	195,6	98,45	054400-089.60
	91,60 – 94,00	424	30000	175	M 16	13,05	120	195,6	98,45	054400-091.60
	93,60 – 96,00	424	30000	175	M 16	13,05	120	195,6	98,45	054400-093.60
	95,60 – 98,00	424	30000	175	M 16	13,05	120	195,6	98,45	054400-095.60
	97,60 – 100,00	424	30000	175	M 16	13,05	120	195,6	98,45	054400-097.60
	99,60 – 102,00	424	30000	175	M 16	13,05	120	195,6	98,45	054400-099.60
	101,60 – 104,00	424	30000	175	M 16	13,05	120	195,6	98,45	054401-101.60
	103,60 – 106,00	424	30000	175	M 16	13,05	120	195,6	98,45	054401-103.60
	105,60 – 108,00	424	30000	175	M 16	13,05	120	195,6	98,45	054401-105.60
	107,60 – 110,00	424	30000	175	M 16	13,05	120	195,6	98,45	054401-107.60
	109,60 – 112,00	424	30000	175	M 16	13,05	120	195,6	98,45	054401-109.60
	111,60 – 114,00	424	30000	175	M 16	13,05	120	195,6	98,45	054402-111.60
	113,60 – 116,00	424	30000	175	M 16	13,05	120	195,6	98,45	054402-113.60
	115,60 – 118,00	424	30000	175	M 16	13,05	120	195,6	98,45	054402-115.60
	117,60 – 120,00	424	30000	175	M 16	13,05	120	195,6	98,45	054402-117.60
	119,60 – 122,00	424	30000	175	M 16	13,05	120	195,6	98,45	054402-119.60
121,60 – 124,00	424	30000	175	M 16	13,05	120	195,6	98,45	054403-121.60	
123,60 – 126,00	424	30000	175	M 16	13,05	120	195,6	98,45	054403-123.60	
125,60 – 128,00	424	30000	175	M 16	13,05	120	195,6	98,45	054403-125.60	
127,60 – 130,00	424	30000	175	M 16	13,05	120	195,6	98,45	054403-127.60	
129,60 – 132,00	424	30000	175	M 16	13,05	120	195,6	98,45	054403-129.60	

* for clamping with pull-back action.

¹⁾ Other clamping ranges available on short notice by request
Power actuating only

Clamping Elements Taper Collets with hexagon head BAD **RINGSPANN®**

for setup of Taper Collet Flange Mandrels BKDF
to different clamping diameters within a given size

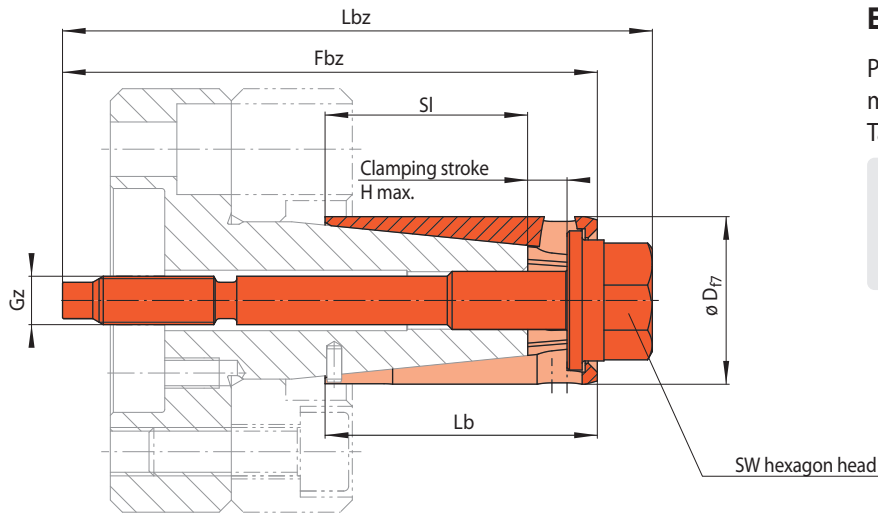

Example for ordering

Please indicate the size of the Clamping Element and the clamping range of the requested Taper Collet, in your order:

Size: BAD 18
Clamping range: 29,70 - 30,90 mm
➔ BAD 27-29,70-30,90

40-1

Size BAD ...	Clamping range ¹⁾	Max. transmissible torque*	Tightening torque for hand clamping*	Fbz	Gz	H max.	Lb	Lbz	SI	SW	Art.-No.
6**	11,90 - 12,50	11	5	61,3	M5	4,1	23	66,5	14,9	6	006500-011.90
	12,40 - 13,00	11	5	61,3	M5	4,1	23	66,5	14,9	6	006500-012.40
	12,90 - 13,50	11	5	61,3	M5	4,1	23	66,5	14,9	6	006500-012.90
	13,40 - 14,00	11	5	61,3	M5	4,1	23	66,5	14,9	6	006500-013.40
	13,90 - 14,50	11	5	61,3	M5	4,1	23	66,5	14,9	6	006500-013.90
	14,40 - 15,00	11	5	61,3	M5	4,1	23	66,5	14,9	6	006500-014.40
7	14,70 - 15,90	13	5	76,3	M5	6,9	35	84,0	24,1	8	007500-014.70
	15,70 - 16,90	13	5	76,3	M5	6,9	35	84,0	24,1	8	007500-015.70
	16,70 - 17,90	13	5	76,3	M5	6,9	35	84,0	24,1	8	007500-016.70
	17,70 - 18,90	13	5	76,3	M5	6,9	35	84,0	24,1	8	007500-017.70
	18,70 - 19,90	13	5	76,3	M5	6,9	35	84,0	24,1	8	007500-018.70
	19,70 - 20,90	13	5	76,3	M5	6,9	35	84,0	24,1	8	007500-019.70
12	20,70 - 21,90	44	20	88,8	M8	6,95	45	98,0	33,55	12	012500-020.70
	21,70 - 22,90	44	20	88,8	M8	6,95	45	98,0	33,55	12	012500-021.70
	22,70 - 23,90	44	20	88,8	M8	6,95	45	98,0	33,55	12	012500-022.70
	23,70 - 24,90	44	20	88,8	M8	6,95	45	98,0	33,55	12	012500-023.70
	24,70 - 25,90	44	20	88,8	M8	6,95	45	98,0	33,55	12	012500-024.70
	25,70 - 26,90	44	20	88,8	M8	6,95	45	98,0	33,55	12	012500-025.70
	26,70 - 27,90	44	20	88,8	M8	6,95	45	98,0	33,55	12	012500-026.70
18	27,70 - 28,90	58	24	87,9	M8	7,0	45	97,5	33,5	17	018500-027.70
	28,70 - 29,90	58	24	87,9	M8	7,0	45	97,5	33,5	17	018500-028.70
	29,70 - 30,90	58	24	87,9	M8	7,0	45	97,5	33,5	17	018500-029.70
	30,60 - 31,80	58	24	87,9	M8	7,0	45	97,5	33,5	17	018500-030.60
	31,60 - 32,80	58	24	87,9	M8	7,0	45	97,5	33,5	17	018500-031.60
19	32,60 - 33,80	114	51	116,3	M12	7,0	65	127,8	52,0	21	019500-032.60
	33,60 - 34,80	114	51	116,3	M12	7,0	65	127,8	52,0	21	019500-033.60
	34,60 - 35,80	114	51	116,3	M12	7,0	65	127,8	52,0	21	019500-034.60
	35,60 - 36,80	114	51	116,3	M12	7,0	65	127,8	52,0	21	019500-035.60
	36,60 - 37,80	114	51	116,3	M12	7,0	65	127,8	52,0	21	019500-036.60
	37,60 - 38,80	114	51	116,3	M12	7,0	65	127,8	52,0	21	019500-037.60
	38,60 - 39,80	114	51	116,3	M12	7,0	65	127,8	52,0	21	019500-038.60
	39,60 - 40,80	114	51	116,3	M12	7,0	65	127,8	52,0	21	019500-039.60
	40,60 - 41,80	114	51	116,3	M12	7,0	65	127,8	52,0	21	019500-040.60
	41,60 - 42,80	114	51	116,3	M12	7,0	65	127,8	52,0	21	019500-041.60
27	42,60 - 43,80	147	62	116,3	M12	7,0	65	130,8	52,0	27	027500-042.60
	43,60 - 44,80	147	62	116,3	M12	7,0	65	130,8	52,0	27	027500-043.60
	44,60 - 45,80	147	62	116,3	M12	7,0	65	130,8	52,0	27	027500-044.60
	45,60 - 46,80	147	62	116,3	M12	7,0	65	130,8	52,0	27	027500-045.60
	46,60 - 47,80	147	62	116,3	M12	7,0	65	130,8	52,0	27	027500-046.60
	47,60 - 48,80	147	62	116,3	M12	7,0	65	130,8	52,0	27	027500-047.60
	48,60 - 49,80	147	62	116,3	M12	7,0	65	130,8	52,0	27	027500-048.60
	49,60 - 50,80	147	62	116,3	M12	7,0	65	130,8	52,0	27	027500-049.60
	50,60 - 51,80	147	62	116,3	M12	7,0	65	130,8	52,0	27	027500-050.60

* for clamping with pull-back action. ** Size BKD 6 without guidance
1) Other clamping ranges available on short notice by request

Assembly group for hand clamping (optional)

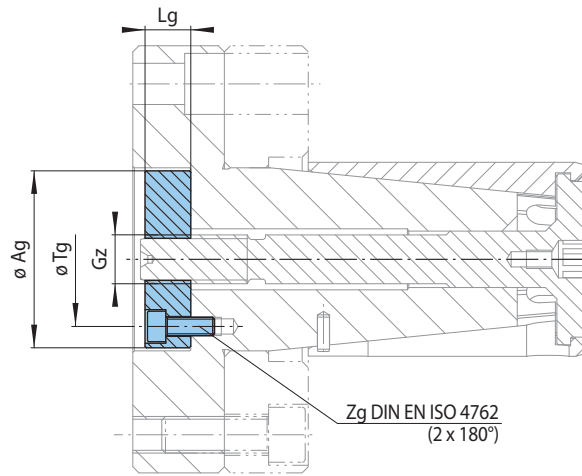

41-1

for size	Max. permissible tightening torque M_A Nm	Ag mm	Gz	Lg mm	Tg mm	Zg	Art.-No.
BKDF 6	5	36	M 5	8	24	M 5	036900
BKDF 7	5	36	M 5	8	24	M 5	036900
BKDF 12	20	36	M 8	8	24	M 5	036902
BKDF 18	24	36	M 8	8	24	M 5	036902
BKDF 19	51	48	M 12	12	34	M 6	048900
BKDF 27	62	48	M 12	12	34	M 6	048900
BKDF 32	113	58	M 16	15	44	M 6	058900
BKDF 43	134	58	M 16	15	44	M 6	058900
BKDF 44	140	58	M 16	15	44	M 6	058900
BKDF 54	159	58	M 16	15	44	M 6	058900

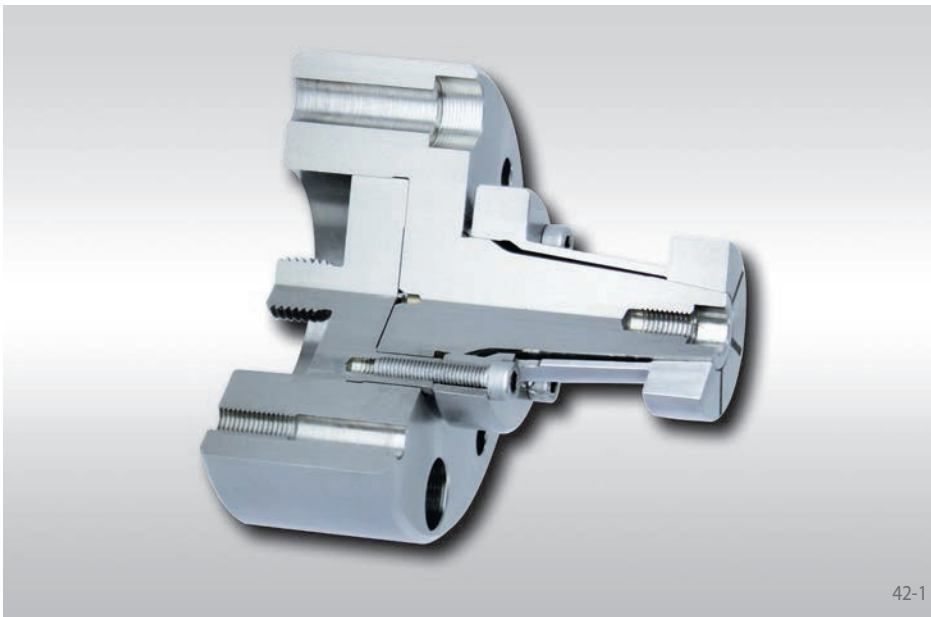

42-1

Features

- For clamping diameters from 9 mm to 275 mm
- High true running accuracy
 $\leq 0,01$ mm by HKDF 4 up to HKDF 125
 $\leq 0,015$ mm by HKDF 150 and HKDF 200
- Permissible component tolerance up to IT13
- Pull-back against external backstop surface or external backstop ring by the customer
- Impervious to ingress of foreign objects due to the rubberized slots in the Taper Sleeve

Configuration

The Taper Sleeve Flange Mandrel consists of a draw plate, a seating body and a Taper Sleeve. The Taper Sleeve Flange Mandrel is attached to the machine with the seating body. The Clamping Fixture is actuated by the draw plate, which is connected to the machine power actuating unit.

Intermediate Flanges and Spring Force Actuators are shown starting on page 58.

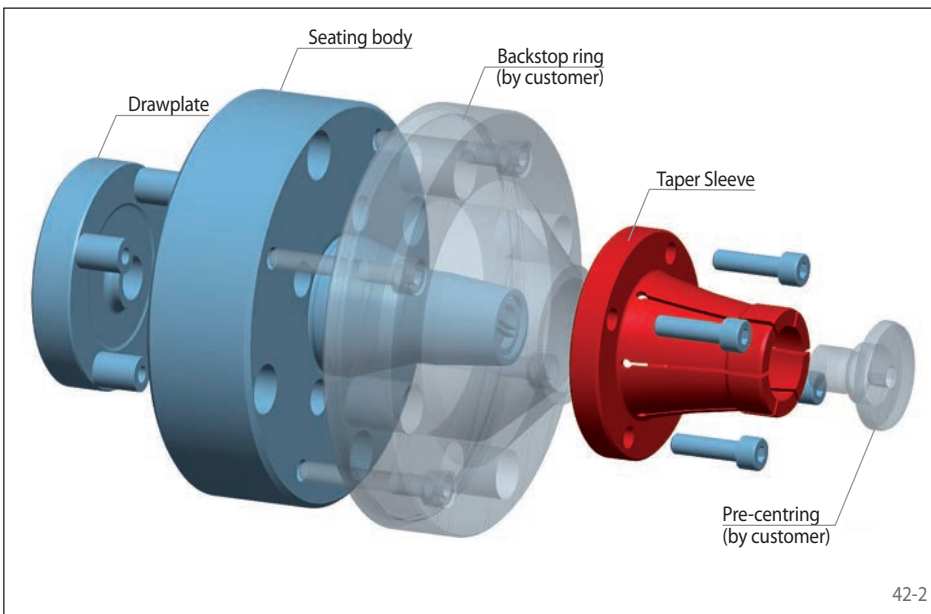

42-2

Clamping principle

For clamping, the Taper Sleeve is pulled against the seating body. The component is centred, pressed against the backstop and aligned flush.

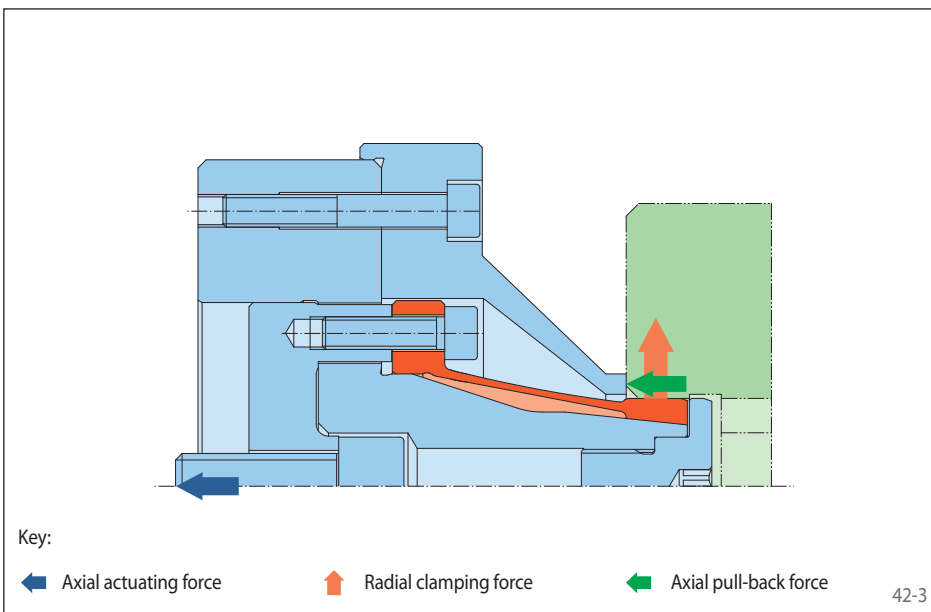

42-3

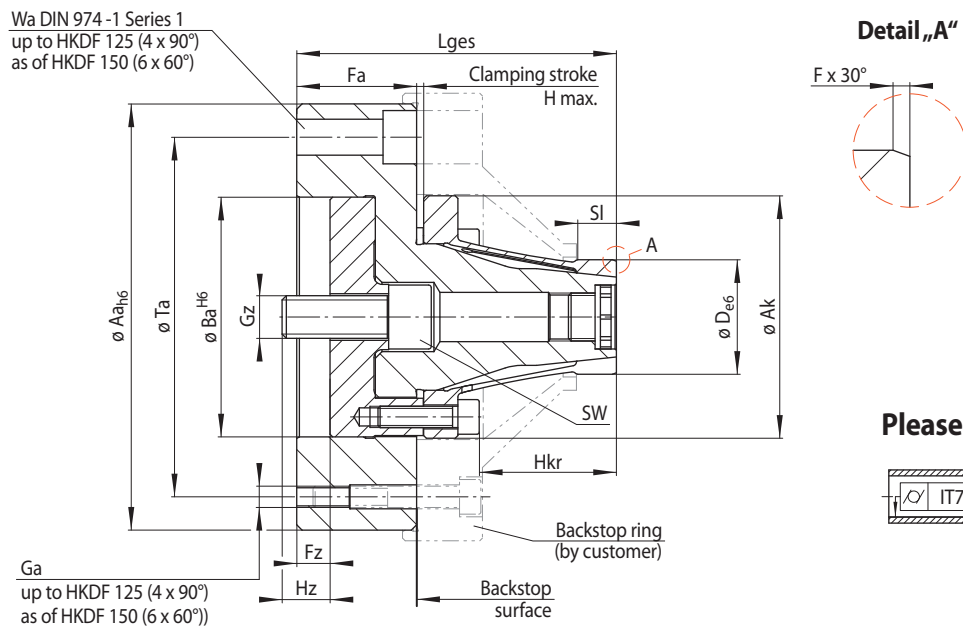

Please note



43-1

Size	Achievable clamping diameter D* mm	Maximum diameter change** Δ D mm	Max. transmissible torque*** M Nm	Max. actuating force*** F N	Aa mm	Ak mm	Ba mm	F mm	Fa mm	Fz mm	Ga mm	Gz mm	H max. mm	Hkr mm	Hz mm	Lges mm	SI mm	SW mm	Ta mm	Wa mm
HKDF 4	9 - 16	0,5	6,5	8000	90	51	50	0,5	36	14	M 6	M 12	2,7	36,5	14	92	7	-	70	8
HKDF 6	15 - 20	0,5	10	9000	90	51	50	0,5	36	14	M 6	M 12	2,7	36,5	14	92	9	-	70	8
HKDF 7	19 - 26	0,5	12	9000	90	51	50	1,0	36	14	M 6	M 12	2,7	36,5	14	92	10	-	70	8
HKDF 12	25 - 32	0,5	22	10000	90	51	50	1,0	36	14	M 6	M 12	2,7	38,5	14	95	10	-	70	8
HKDF 19	31 - 44	0,5	55	16000	120	61	60	1,0	49	19	M 8	M 16	2,7	47,5	18	118	15	-	95	10
HKDF 30	43 - 55	0,5	158	30000	160	91	90	1,0	45	12,5	M 8	M 16	2,8	51,5	18	120	15	14	135	12
HKDF 40	54 - 76	0,5	278	40000	160	91	90	1,0	45	12,5	M 8	M 16	2,8	61,5	18	130	15	14	135	12
HKDF 60	75 - 100	0,5	613	60000	185	126	125	1,0	57	12,5	M 8	M 20	2,9	58,5	20	143	15	17	160	12
HKDF 80	100 - 125	0,8	1050	80000	250	170	175	2,0	68	15,1	M 10	M 20	4,5	68	22	172,5	20	17	225	12
HKDF 100	125 - 150	0,8	1300	80000	250	170	175	2,0	68	15,1	M 10	M 20	4,5	68	22	172,5	20	17	225	12
HKDF 125	150 - 175	1,0	2050	100000	275	200	200	3,0	73	15,5	M 10	M 20	5,0	75	27,5	188	25	17	250	12
HKDF 150	175 - 225	1,2	3000	140000	300	230	225	3,0	89,5	20	M 10	M 24	7,5	98	50	240	30	19	260	16
HKDF 200	225 - 275	1,5	4500	170000	350	280	275	3,0	106,5	20	M 10	M 24	8,5	115	40	275	30	19	315	16

* Clamping diameter adjustable to two places after the decimal point • ** of the clamping diameter of the Clamping Element. • *** for clamping with pull-back action.

Example for ordering

Please indicate the size of the Clamping Fixture and the clamping diameter of your component, including component tolerance, in your order:

Size: HKDF 30
Clamping diameter: 50,47 mm
Component tolerance: H7

➔ HKDF 30-50,47H7

for setup of Taper Sleeve Flange Mandrels HKDF
to different clamping diameters within a given size

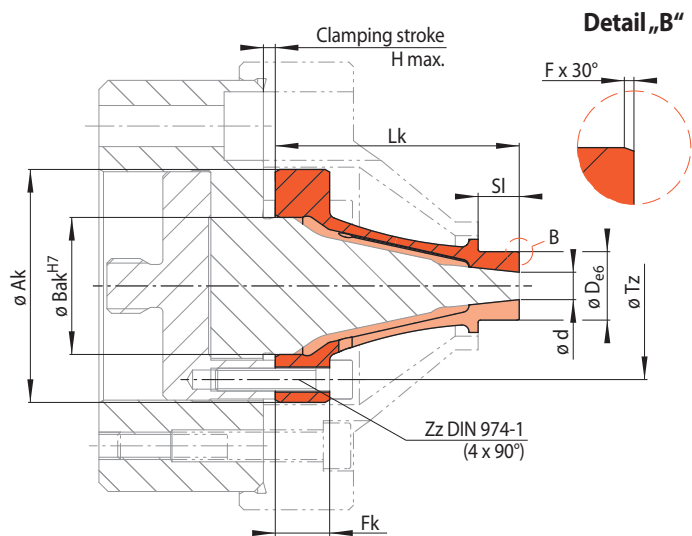

Sizes HKD 4 und HKD 6

44-1

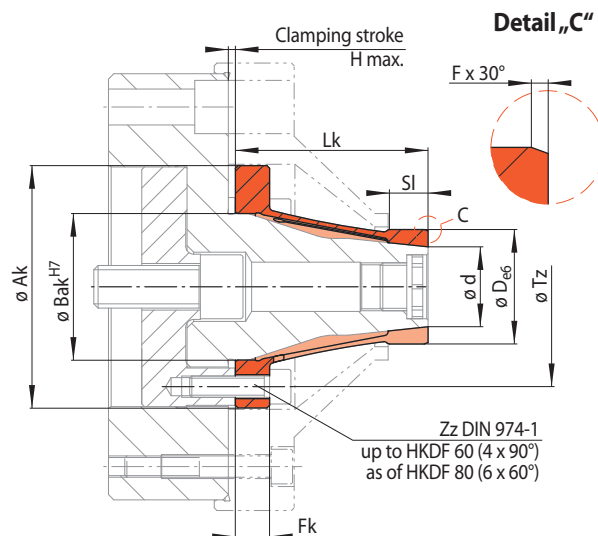

Sizes HKD 7 to HKD 200

44-2

Size HKD ...	Achievable clamping diameter	Maximum diameter change**	Max. transmissible torque***	Max. actuating force***	Ak	Bak	F	Fk	H max. ****	Lk	SI	Tz	Zz	Art.-No.
d mm	D* mm	ΔD mm	M Nm	F N	mm	mm	mm	mm	mm	mm	mm	mm		2198-
4	9 - 16	0,5	6,5	8000	51	30	0,5	12	2,7	53,3	7	41	M 5	004501
6	15 - 20	0,5	10	9000	51	30	0,5	12	2,7	53,3	9	41	M 5	006501
7	19 - 26	0,5	12	9000	51	30	1,0	12	2,7	53,3	10	41	M 5	007501
12	25 - 32	0,5	22	10000	51	31	1,0	13	2,7	56,3	10	41	M 5	012501
19	31 - 44	0,5	55	16000	61	34	1,0	13	2,7	66,3	15	49	M 6	019501
30	43 - 55	0,5	158	30000	91	55	1,0	12,7	2,8	72,2	15	75	M 8	030501
40	54 - 76	0,5	278	40000	91	55	1,0	12,7	2,8	82,2	15	75	M 8	040501
60	75 - 100	0,5	613	60000	126	81	1,0	14,6	2,9	83,1	15	107	M 10	060501
80	100 - 125	0,8	1050	80000	170	110	2,0	20	4,5	100	20	145	M 12	080501
100	125 - 150	0,8	1300	80000	170	110	2,0	20	4,5	100	20	145	M 12	100501
125	150 - 175	1,0	2050	100000	200	135	3,0	23	5,0	110	25	170	M 12	125501
150	175 - 225	1,2	3000	140000	230	160	3,0	33	7,5	143	30	195	M 12	150501
200	225 - 275	1,5	4500	170000	280	210	3,0	33	8,5	160	30	245	M 12	200501

* Clamping diameter adjustable to two places after the decimal point. ** of the clamping diameter of the Clamping Element. *** for clamping with pull-back action. **** Clamping stroke H max. describes the load limit of the Clamping Element while activation without component.

Example for ordering

Please indicate the size of the Clamping Element and the clamping diameter of your component, including component tolerance, in your order:

Size: HKD 30
Clamping diameter: 50,47 mm
Component tolerance: H7

➔ HKD 30-50,47H7

Assembly group for hand clamping (optional)

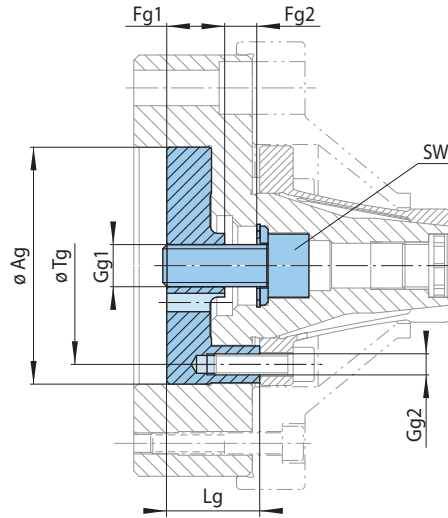

45-1

for size*	Max. permissible tightening torque M_A Nm	Ag mm	Fg1 mm	Fg2 mm	Gg1	Gg2	Lg mm	SW	Art.-No.
HKDF 30	78	90	22,0	12,2	M 16 x 1,5 LH	M 8	35,3	14	090902
HKDF 40	105	90	22,0	14,25	M 16 x 1,5 LH	M 8	35,3	14	090902
HKDF 60	230	125	23,5	28,4	M 24 x 2 LH	M 10	47,4	19	125901
HKDF 80	302	175	28,9	23,4	M 24 x 2 LH	M 12	57,4	19	175901
HKDF 100	302	175	28,9	23,4	M 24 x 2 LH	M 12	57,4	19	175901
HKDF 125	380	200	33,5	23,4	M 24 x 2 LH	M 12	62,5	19	200901
HKDF 150	530	225	41,0	47,4	M 24 x 2 LH	M 12	77,0	19	225901
HKDF 200	645	275	51,0	37,4	M 24 x 2 LH	M 12	95,0	19	275901

* Assembly group for hand clamping is not available for Taper Sleeve Flange Mandrels HKDF 4 to HKDF 19.



46-1

Features

- For clamping diameters from 120 mm to 375 mm
- High true running accuracy $\leq 0,01$ mm
- Permissible component tolerance up to IT11
- Very short clamping fixture length
- Short clamping length
- Pull-back against external backstop surface or external backstop ring by the customer
- Hand clamping optional possible
- Rubberized slots in the Flat Element

Configuration

The Flat Element Flange Mandrel consists of a seating body, a thrust bolt, a set of spacer bushes, a Flat Element and a cover. An assembly for hand clamping is optionally available. The Flat Element Flange Mandrel is attached with the seating body to the machine. The Clamping Fixture is actuated by the thrust bolt, which is connected to the machine power actuating unit.

Intermediate Flanges and Spring Force Actuators are shown starting on page 58.

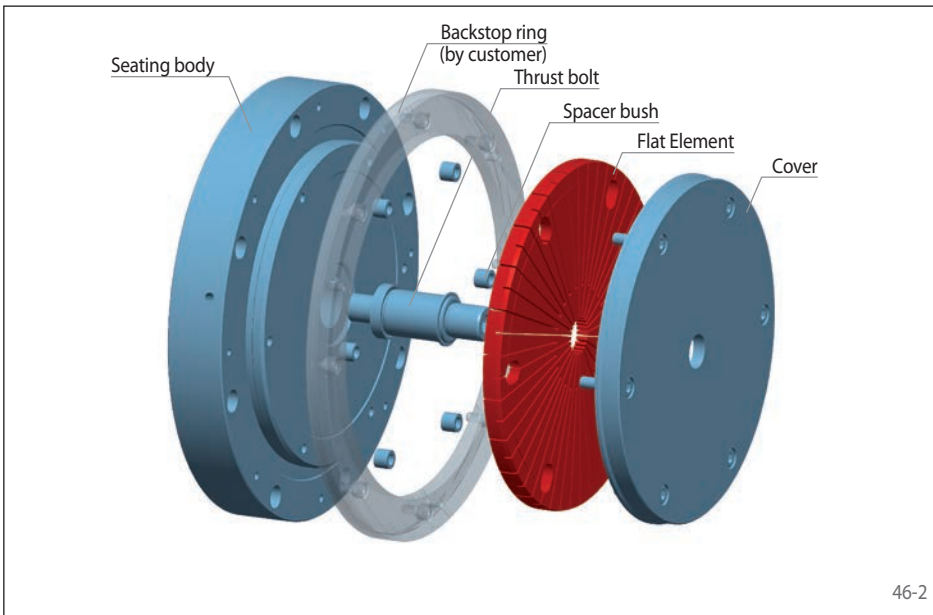

46-2

Clamping principle

The Flat Element sits pre-loaded on the seating diameter of the seating body. For clamping, the Flat Element is elastically deformed by an axial actuating force. The component is centred, pressed against the backstop and aligned flush.

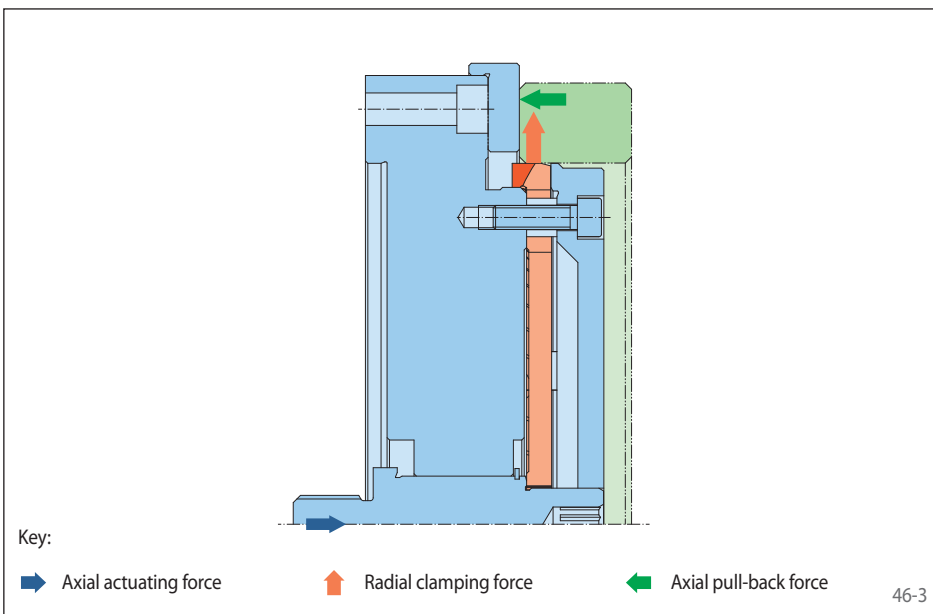

46-3

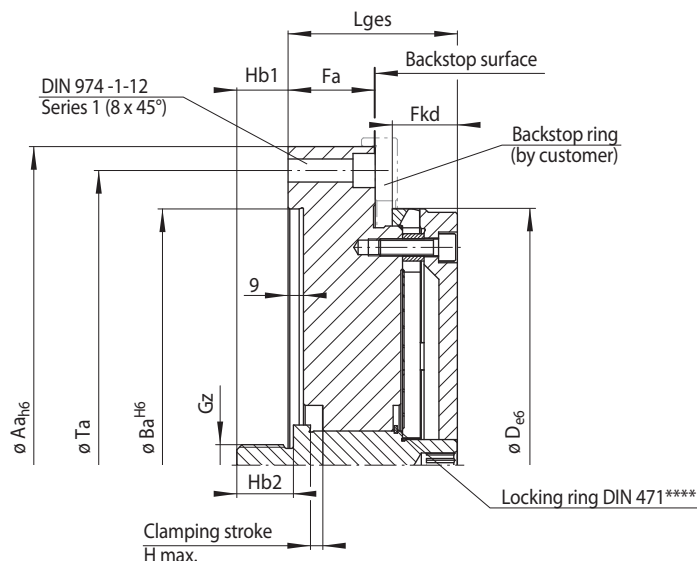

47-1

Size	Achievable clamping diameter	Maximum diameter change**	Max. transmissible torque***	Max. actuating force***	Aa	Ba	Fa	Fkd	Gz	H max.	Hb1	Hb2	Lges	Ta
	D* mm	ΔD mm	M Nm	F N	mm	mm	mm	mm		mm	mm	mm	mm	mm
KFDF 110	120 - 130	0,28	620	13700	200	125	32	23	M 16	3,4	16,5	22	63,1	175
KFDF 120	130 - 145	0,30	760	13700	200	125	32	23	M 16	3,8	16,5	22	63,1	175
KFDF 130	145 - 155	0,30	1230	19600	200	125	40	27	M 20	4,0	21,0	26	75,1	175
KFDF 140	155 - 170	0,34	1350	19600	250	175	40	27	M 20	4,5	21,0	26	75,1	225
KFDF 155	170 - 185	0,37	1500	19600	250	175	40	29	M 20	5,1	21,0	26	77,1	225
KFDF 170	185 - 200	0,43	1600	19600	250	175	40	29	M 20	5,8	21,0	26	77,1	225
KFDF 185	200 - 220	0,47	1800	19600	275	200	40	29	M 20	6,4	21,0	26	77,1	250
KFDF 200	220 - 240	0,50	2850	29400	315	240	51	34	M 24	6,7	30,0	30	95,1	280
KFDF 220	240 - 260	0,57	3150	29400	315	240	51	34	M 24	7,8	30,0	30	95,1	280
KFDF 240	260 - 280	0,64	3450	29400	375	300	51	34	M 24	8,5	30,0	30	95,1	345
KFDF 260	280 - 300	0,70	3700	29400	375	300	51	34	M 24	9,4	30,0	30	95,1	345
KFDF 280	300 - 325	0,75	4100	29400	375	300	51	38	M 24	10,2	30,0	30	99,1	345
KFDF 300	325 - 350	0,80	4500	29400	400	350	51	38	M 24	11,3	30,0	30	99,1	375
KFDF 325	350 - 375	0,80	5300	29400	425	375	51	40	M 24	12,5	30,0	30	100,6	400

* Clamping diameter adjustable to two places after the decimal point • ** of the clamping diameter of the Clamping Element. • *** for clamping with pull-back action.
 **** The locking ring prevents loss of the pressure bolt during transport and storage of the Clamping Fixture. It must be removed prior to installation and commissioning.

Example for ordering

Please indicate the size of the Clamping Fixture and the clamping diameter of your component, including component tolerance, in your order:

Size: KFDF 120
 Clamping diameter: 140,47 mm
 Component tolerance: H7

➔ KFDF 120-140,47H7

Clamping Elements Flat Elements KFD

for setup of Flat Element Flange Mandrels KFDF
to different clamping diameters within a given size

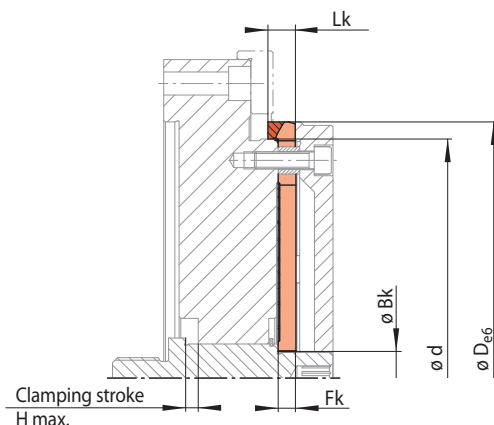

48-1

Size KFD ...	Achievable clamping diameter	Maximum diameter change**	Max. transmissible torque***	Max. actuating force***	Bk	Fk	H max. ****	Lk	Art.-No.
d mm	D* mm	Δ D mm	M Nm	F N	mm	mm	mm	mm	1192-
35	41 - 47	0,15	38	5900	10,5	3	0,8	6	035004
40	47 - 55	0,15	52	5700	10,5	3	0,9	6	040004
46	54 - 62	0,20	89	9800	12,5	4	1,1	8	046004
52	60 - 72	0,20	120	9500	12,5	4	1,3	8	052004
62	70 - 80	0,21	170	9200	12,5	4	1,7	8	062004
72	80 - 90	0,21	235	8900	12,5	4	2,1	8	072004
80	90 - 100	0,27	340	14200	16,5	5	2,2	10	080004
90	100 - 110	0,27	450	14200	16,5	5	2,6	10	090004
100	110 - 120	0,28	560	14200	16,5	5	3,1	10	100004
110	120 - 130	0,28	620	13700	16,5	5	3,4	10	110004
120	130 - 145	0,30	760	13700	16,5	5	3,8	10	120002
130	145 - 155	0,30	1230	19600	21,0	6	4,0	12	130002
140	155 - 170	0,34	1350	19600	21,0	6	4,5	12	140002
155	170 - 185	0,37	1500	19600	21,0	6	5,1	12	155002
170	185 - 200	0,43	1600	19600	21,0	6	5,8	12	170002
185	200 - 220	0,47	1800	19600	21,0	6	6,4	12	185002
200	220 - 240	0,50	2850	29400	31,5	8	6,7	14	200002
220	240 - 260	0,57	3150	29400	31,5	8	7,8	14	220002
240	260 - 280	0,64	3450	29400	31,5	8	8,5	14	240002
260	280 - 300	0,70	3700	29400	31,5	8	9,4	14	260002
280	300 - 325	0,75	4100	29400	32,0	10	10,2	16	280002
300	325 - 350	0,80	4500	29400	32,0	10	11,3	16	300002
325	350 - 375	0,80	5300	29400	32,0	10	12,5	16	325002
350	375 - 400	0,80	5800	29400	52,0	10	12,7	16	350002
375	400 - 425	0,85	6300	29400	52,0	10	13,7	16	375002
400	425 - 455	0,95	6500	29400	52,0	10	15,0	16	400002
425	455 - 485	1,00	6000	24500	52,0	12	16,1	18	425002
455	485 - 520	1,05	6600	24500	52,0	12	17,1	18	455002
490	520 - 560	1,10	7200	24500	52,0	12	18,3	18	490002

* Clamping diameter adjustable to two places after the decimal point • ** of the clamping diameter of the Clamping Element. • *** for clamping with pull-back action.
**** Clamping stroke H max. describes the load limit of the Clamping Element while activation without component.

Example for ordering

Please indicate the size of the Clamping Element and the clamping diameter of your component, including component tolerance, in your order:

Size: KFD 40
Clamping diameter: 50,47 mm
Component tolerance: H7
➔ KFD 40-50,47H7

Assembly group for hand clamping (optional)

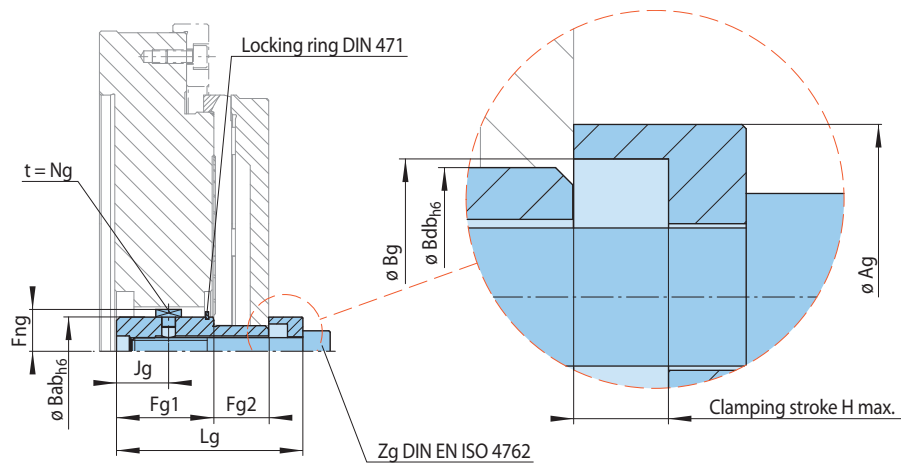

49-1

for size	Max. permissible tightening torque M_A Nm	Ag	Bab	Bdb	Bg	Fg1	Fg2	Fng	H max.*	Jg	Lg	Ng	Zg	Art.-No.
KFDF 110	23	22	22	16	17	32,5	17,5	13,3	3,4	17,5	58,6	5	M 10	022900
KFDF 120	23	22	22	16	17	32,5	17,5	13,3	3,8	17,5	58,6	5	M 10	022900
KFDF 130	39	32	28	20	22	41,0	23,0	18,5	4,0	23,0	73,1	8	M 12	028900
KFDF 140	39	32	28	20	22	41,0	23,0	18,5	4,5	23,0	73,1	8	M 12	028900
KFDF 155	39	32	28	20	22	41,0	23,0	18,5	5,1	23,0	75,1	8	M 12	028900
KFDF 170	39	32	28	20	22	41,0	23,0	18,5	5,8	23,0	75,1	8	M 12	028900
KFDF 185	39	32	28	20	22	41,0	23,0	18,5	6,4	23,0	75,1	8	M 12	028900
KFDF 200	76	40	40	30	32	57,0	32,0	24,5	6,7	30,5	105,1	8	M 16	040900
KFDF 220	76	40	40	30	32	57,0	32,0	24,5	7,8	30,5	105,1	8	M 16	040900
KFDF 240	76	40	40	30	32	57,0	32,0	24,5	8,5	30,5	105,1	8	M 16	040900
KFDF 260	76	40	40	30	32	57,0	32,0	24,5	9,4	30,5	105,1	8	M 16	040900
KFDF 280	76	40	40	30	32	57,0	32,0	24,5	10,2	30,5	109,1	8	M 16	040900
KFDF 300	76	40	40	30	32	57,0	32,0	24,5	11,3	30,5	109,1	8	M 16	040900
KFDF 325	76	40	40	30	32	57,0	32,0	24,5	12,5	30,5	110,6	8	M 16	040900

* Clamping stroke H max. describes the load limit of the Clamping Element while activation without component.



50-1

Features

- For clamping diameters from 11,9 mm to 132 mm
- High true running accuracy $\leq 0,01$ mm
- Permissible component tolerance up to IT15
- Pull-back against external backstop ring by the customer
- For thin-walled or solid components
- For hand clamping

Configuration

The Taper Collet Centre Mandrel consists of a centre mandrel body and a Taper Collet with a clamping nut. The Taper Collet Centre Mandrel is mounted between the centring tips. The Taper Collet is activated by turning the clamping nut.

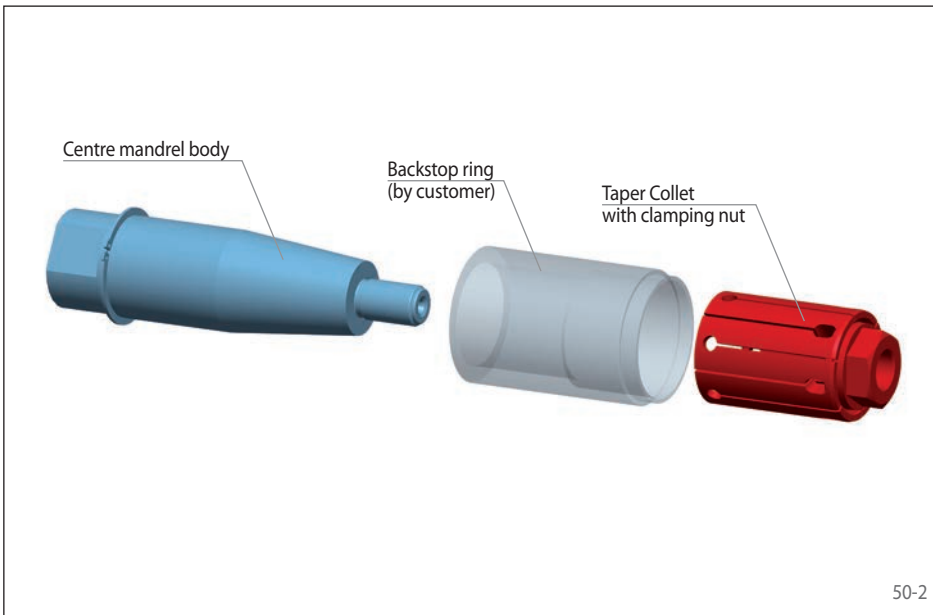

50-2

Clamping principle

For clamping, the Taper Collet is pushed against the centre mandrel body and radially expands over the cone of basebody. The component is centred, pressed against the backstop and aligned flush.

The cylindrical form of the component bore in the clamping area has to be smaller than the tolerance class IT7, independent of the component bore tolerance.

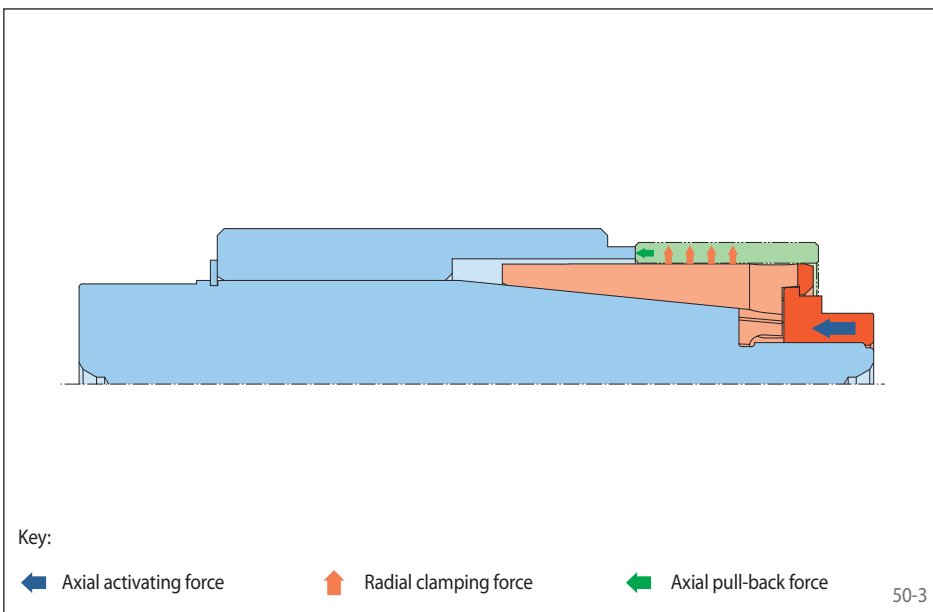

50-3

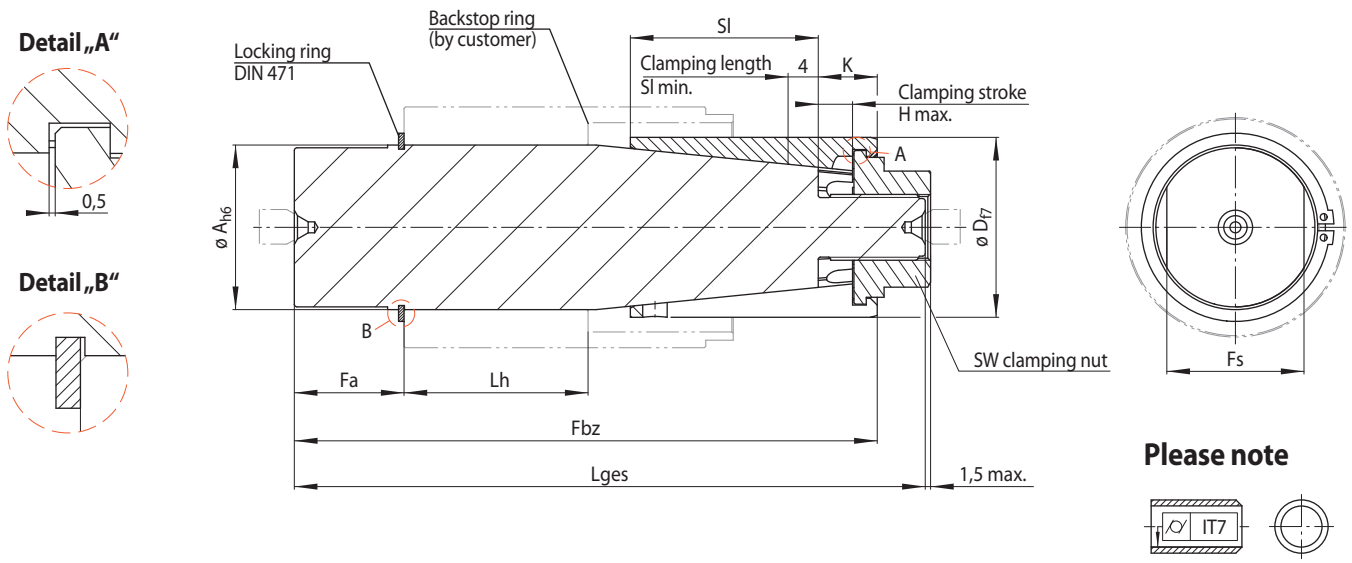

Please note



51-1

Size	Clamping range	Maximum diameter change*	Max. transmissible torque**	Tightening torque**	A	Fa	Fbz	Fs	H max.	K	Lges	Lh max.	SI	SW
	D ¹⁾ mm	ΔD mm	M Nm	M _H Nm	mm	mm	mm	mm	mm	mm	mm	mm	mm	mm
BKDI 6	11,90 - 15,00	0,6	11	5	11	17,0	69,5	8	4,1	8,1	77	24	14,9	9
BKDI 7	14,70 - 20,90	1,2	13	7	14	17,0	83,9	10	6,9	10,9	90	24	24,1	11
BKDI 12	20,70 - 27,90	1,2	44	25	20	21,2	102,45	15	6,95	11,45	110	28	33,55	17
BKDI 18	27,70 - 32,80	1,2	58	37	26	21,2	102,5	17	7,0	11,5	110	28	33,5	17
BKDI 19	32,60 - 42,80	1,2	114	67	30	28,5	148,0	24	7,0	13,0	160	46	52,0	27
BKDI 27	42,60 - 51,80	1,2	147	78	39	28,75	148,0	27	7,0	13,0	160	46	52,0	27
BKDI 32	51,60 - 64,00	2,4	273	153	49	39,75	212,5	41	13,0	21,5	230	68	68,5	41
BKDI 43	63,60 - 72,00	2,4	333	175	60	40,0	212,5	41	13,0	21,5	230	68	68,5	41
BKDI 44	71,60 - 82,00	2,4	373	204	66	48,5	277,5	55	13,0	21,5	300	94	98,5	55
BKDI 54	81,60 - 132,00	2,4	424	222	77	48,5	277,55	55	13,05	21,55	300	94	98,45	55

¹⁾ Please note the standard clamping ranges according to the tables on the next pages „Clamping Elements Taper Collets BMD“.

* of the clamping diameter of the Clamping Element.

** for clamping with pull-back action.

Example for ordering

Please indicate the size of the Clamping Fixture and the clamping range of the requested Taper Collet, in your order:

Size: BKDI 12
 Clamping range: 23,70 - 24,90 mm
 ➔ BKDI 12-23,70-24,90

Insertion depth

The minimum insertion depth $Le_{min.}$ is derived according to the following formula from the component chamfer length Lf and dimension K :

$$Le_{min.} = K + Lf + 4 \text{ mm (SI}_{min.})$$

for setup of Taper Collet Centre Mandrels BKDI
to different clamping diameters within a given size

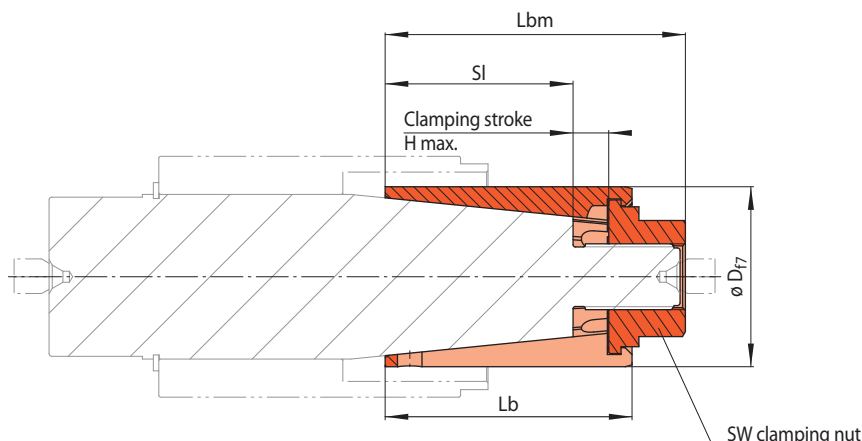

Example for ordering

Please indicate the size of the Clamping Element and the clamping range of the requested Taper Collet, in your order:

Size: BMD 6
Clamping range: 13,40 - 14,00 mm
➔ BMD 6-13,40-14,00

52-1

Size BMD ...	Clamping range ¹⁾ D mm	Max. transmissible torque* M Nm	Tightening torque* M _H Nm	H max. mm	Lb mm	Lbm mm	SI mm	SW mm	Art.-No.
									3198-
6	11,90 - 12,50	11	7	4,1	23	30,0	14,9	9	006102-011.90
	12,40 - 13,00	11	7	4,1	23	30,0	14,9	9	006102-012.40
	12,90 - 13,50	11	7	4,1	23	30,0	14,9	9	006102-012.90
	13,40 - 14,00	11	7	4,1	23	30,0	14,9	9	006102-013.40
	13,90 - 14,50	11	7	4,1	23	30,0	14,9	9	006102-013.90
	14,40 - 15,00	11	7	4,1	23	30,0	14,9	9	006102-014.40
7	14,70 - 15,90	13	8	6,9	35	42,0	24,1	11	007102-014.70
	15,70 - 16,90	13	8	6,9	35	42,0	24,1	11	007102-015.70
	16,70 - 17,90	13	8	6,9	35	42,0	24,1	11	007102-016.70
	17,70 - 18,90	13	8	6,9	35	42,0	24,1	11	007102-017.70
	18,70 - 19,90	13	8	6,9	35	42,0	24,1	11	007102-018.70
	19,70 - 20,90	13	8	6,9	35	42,0	24,1	11	007102-019.70
12	20,70 - 21,90	44	28	6,95	45	53,0	33,55	17	012102-020.70
	21,70 - 22,90	44	28	6,95	45	53,0	33,55	17	012102-021.70
	22,70 - 23,90	44	28	6,95	45	53,0	33,55	17	012102-022.70
	23,70 - 24,90	44	28	6,95	45	53,0	33,55	17	012102-023.70
	24,70 - 25,90	44	28	6,95	45	53,0	33,55	17	012102-024.70
	25,70 - 26,90	44	28	6,95	45	53,0	33,55	17	012102-025.70
	26,70 - 27,90	44	28	6,95	45	53,0	33,55	17	012102-026.70
18	27,70 - 28,90	58	37	7,0	45	53,0	33,5	17	018103-027.70
	28,70 - 29,90	58	37	7,0	45	53,0	33,5	17	018103-028.70
	29,70 - 30,90	58	37	7,0	45	53,0	33,5	17	018103-029.70
	30,60 - 31,80	58	37	7,0	45	53,0	33,5	17	018103-030.60
	31,60 - 32,80	58	37	7,0	45	53,0	33,5	17	018103-031.60
19	32,60 - 33,80	114	73	7,0	65	77,5	52,0	27	018104-032.60
	33,60 - 34,80	114	73	7,0	65	77,5	52,0	27	018104-033.60
	34,60 - 35,80	114	73	7,0	65	77,5	52,0	27	018104-034.60
	35,60 - 36,80	114	73	7,0	65	77,5	52,0	27	018104-035.60
	36,60 - 37,80	114	73	7,0	65	77,5	52,0	27	018104-036.60
	37,60 - 38,80	114	73	7,0	65	77,5	52,0	27	018104-037.60
	38,60 - 39,80	114	73	7,0	65	77,5	52,0	27	018104-038.60
	39,60 - 40,80	114	73	7,0	65	77,5	52,0	27	018104-039.60
	40,60 - 41,80	114	73	7,0	65	77,5	52,0	27	018104-040.60
41,60 - 42,80	114	73	7,0	65	77,5	52,0	27	018104-041.60	
27	42,60 - 43,80	147	95	7,0	65	77,5	52,0	27	027102-042.60
	43,60 - 44,80	147	95	7,0	65	77,5	52,0	27	027102-043.60
	44,60 - 45,80	147	95	7,0	65	77,5	52,0	27	027102-044.60
	45,60 - 46,80	147	95	7,0	65	77,5	52,0	27	027102-045.60
	46,60 - 47,80	147	95	7,0	65	77,5	52,0	27	027102-046.60
	47,60 - 48,80	147	95	7,0	65	77,5	52,0	27	027102-047.60
	48,60 - 49,80	147	95	7,0	65	77,5	52,0	27	027102-048.60
	49,60 - 50,80	147	95	7,0	65	77,5	52,0	27	027102-049.60
	50,60 - 51,80	147	95	7,0	65	77,5	52,0	27	027102-050.60

* for clamping with pull-back action. • ¹⁾ Other clamping ranges available on short notice by request

for setup of Taper Collet Centre Mandrels BKDI
to different clamping diameters within a given size

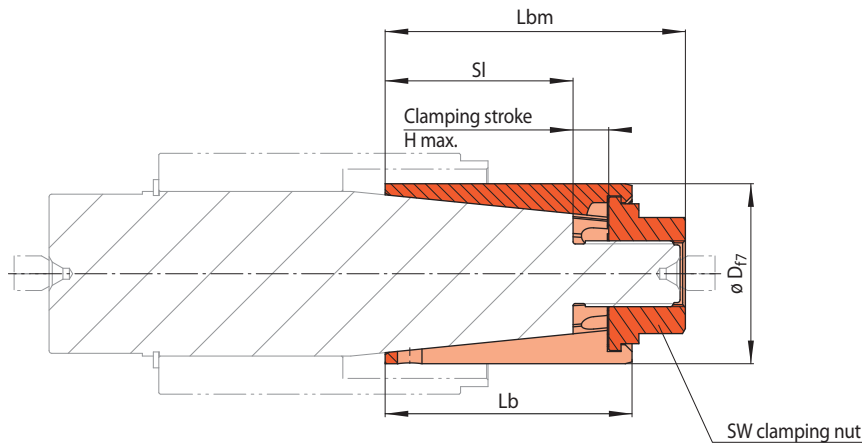

Example for ordering

Please indicate the size of the Clamping Element and the clamping range of the requested Taper Collet, in your order:

Size: BMD 32
Clamping range: 57,60 - 60,00 mm
➔ BMD 32-57,60-60,00

53-1

Size BMD ...	Clamping range ¹⁾ D mm	Max. transmissible torque* M Nm	Tightening torque* M _H Nm	H max. mm	Lb mm	Lbm mm	SI mm	SW mm	Art.-No. 3198-
32	51,60 - 54,00	273	170	13	90	107,5	68,5	41	032102-051.60
	53,60 - 56,00	273	170	13	90	107,5	68,5	41	032102-053.60
	55,60 - 58,00	273	170	13	90	107,5	68,5	41	032102-055.60
	57,60 - 60,00	273	170	13	90	107,5	68,5	41	032102-057.60
	59,60 - 62,00	273	170	13	90	107,5	68,5	41	032102-059.60
	61,60 - 64,00	273	170	13	90	107,5	68,5	41	032102-061.60
43	63,60 - 66,00	333	214	13	90	107,5	68,5	41	043103-063.60
	65,60 - 68,00	333	214	13	90	107,5	68,5	41	043103-065.60
	67,60 - 70,00	333	214	13	90	107,5	68,5	41	043103-067.60
	69,60 - 72,00	333	214	13	90	107,5	68,5	41	043103-069.60
44	71,60 - 74,00	373	227	13	120	142,5	98,5	55	043104-071.60
	73,60 - 76,00	373	227	13	120	142,5	98,5	55	043104-073.60
	75,60 - 78,00	373	227	13	120	142,5	98,5	55	043104-075.60
	77,60 - 80,00	373	227	13	120	142,5	98,5	55	043104-077.60
	79,60 - 82,00	373	227	13	120	142,5	98,5	55	043104-079.60
54	81,60 - 84,00	424	265	13,05	120	142,5	98,45	55	054102-081.60
	83,60 - 86,00	424	265	13,05	120	142,5	98,45	55	054102-083.60
	85,60 - 88,00	424	265	13,05	120	142,5	98,45	55	054102-085.60
	87,60 - 90,00	424	265	13,05	120	142,5	98,45	55	054102-087.60
	89,60 - 92,00	424	265	13,05	120	142,5	98,45	55	054102-089.60
	91,60 - 94,00	424	265	13,05	120	142,5	98,45	55	054102-091.60
	93,60 - 96,00	424	265	13,05	120	142,5	98,45	55	054102-093.60
	95,60 - 98,00	424	265	13,05	120	142,5	98,45	55	054102-095.60
	97,60 - 100,00	424	265	13,05	120	142,5	98,45	55	054102-097.60
	99,60 - 102,00	424	265	13,05	120	142,5	98,45	55	054102-099.60
	101,60 - 104,00	424	265	13,05	120	142,5	98,45	55	054106-101.60
	103,60 - 106,00	424	265	13,05	120	142,5	98,45	55	054106-103.60
	105,60 - 108,00	424	265	13,05	120	142,5	98,45	55	054106-105.60
	107,60 - 110,00	424	265	13,05	120	142,5	98,45	55	054106-107.60
	109,60 - 112,00	424	265	13,05	120	142,5	98,45	55	054106-109.60
	111,60 - 114,00	424	265	13,05	120	142,5	98,45	55	054107-111.60
	113,60 - 116,00	424	265	13,05	120	142,5	98,45	55	054107-113.60
	115,60 - 118,00	424	265	13,05	120	142,5	98,45	55	054107-115.60
	117,60 - 120,00	424	265	13,05	120	142,5	98,45	55	054107-117.60
	119,60 - 122,00	424	265	13,05	120	142,5	98,45	55	054107-119.60
121,60 - 124,00	424	265	13,05	120	142,5	98,45	55	054108-121.60	
123,60 - 126,00	424	265	13,05	120	142,5	98,45	55	054108-123.60	
125,60 - 128,00	424	265	13,05	120	142,5	98,45	55	054108-125.60	
127,60 - 130,00	424	265	13,05	120	142,5	98,45	55	054108-127.60	
129,60 - 132,00	424	265	13,05	120	142,5	98,45	55	054108-129.60	

* for clamping with pull-back action. • ¹⁾ Other clamping ranges available on short notice by request

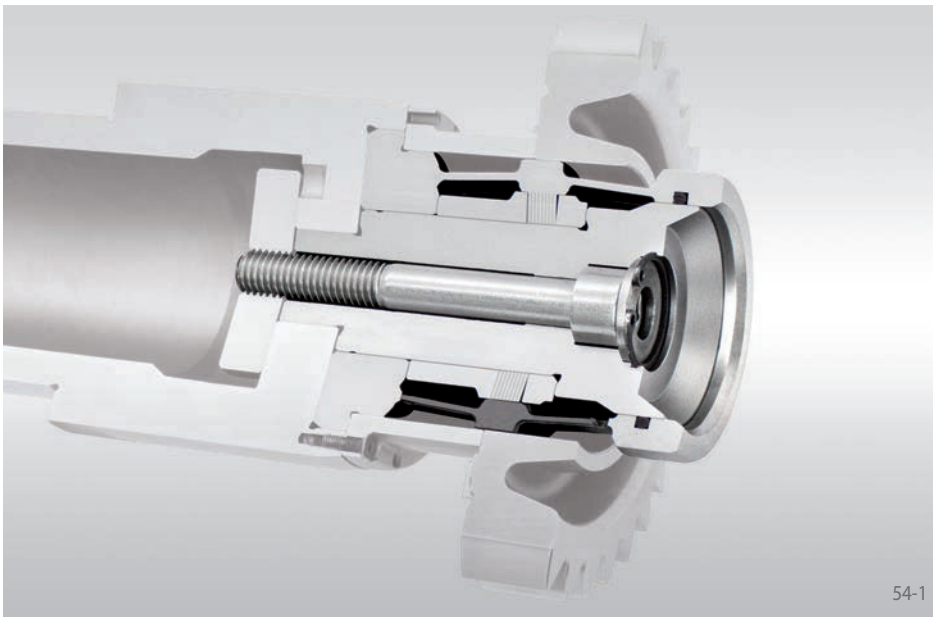

54-1

Features

- For clamping diameters from 25 mm to 82,5 mm
- Excellent suitability for the clamping of workpieces to gearing processing works
- High true running accuracy $\leq 0,005$ mm
- Permissible component tolerance up to IT 10
- Pull-back against external Intermediate Flange ring by the customer
- Also suitable for clamping on short clamping lengths or clamping surfaces interrupted by grooves
- Hand clamping optional possible
- Impervious to ingress of foreign objects due to the rubberized slots in the Expanding Sleeve

Configuration

The Expanding Sleeve Mandrel is composed of the assembly group draw bush and the assembly group Expanding Sleeve. For manual clamping, the addition of a threaded plate is required. The Expanding Sleeve Mandrel is screwed together with the Intermediate Flange to the machine connection. The highest level of true running accuracy is achieved when the Expanding Sleeve is finished by grinding with the Intermediate Flange after assembly. The Clamping Fixture is operated by the central assembly group draw bush, which is connected to the power clamping device of the machine.

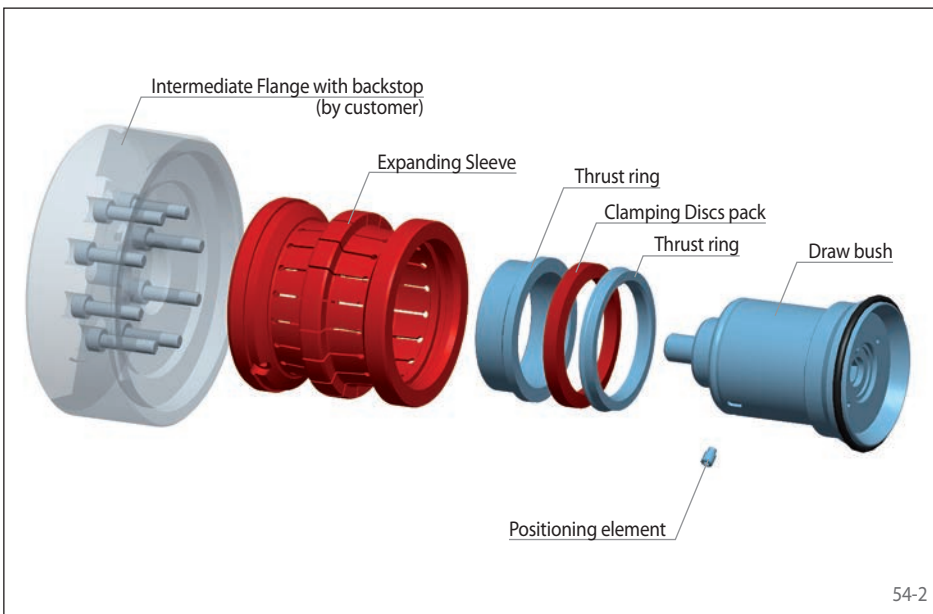

54-2

Clamping principle

A pack of RINGSPANN Clamping Discs sits on the draw bush. Above that, there is a slotted Expanding Sleeve screwed together with a Intermediate Flange. When axial actuating force is applied, the Clamping Discs are evenly expanded over their entire circumference – and the Expanding Sleeve at the same time as a result. Reinforced by tapered design of the deformation zones, the slotted Expanding Sleeve shortens causing the clamped workpiece to be pulled back against the backstop. An additional tailstock or centering tip gives the Expanding Sleeve Mandrel a greater total stiffness after the clamping action. The tailstock or centering tip supports the Expanding Sleeve only.

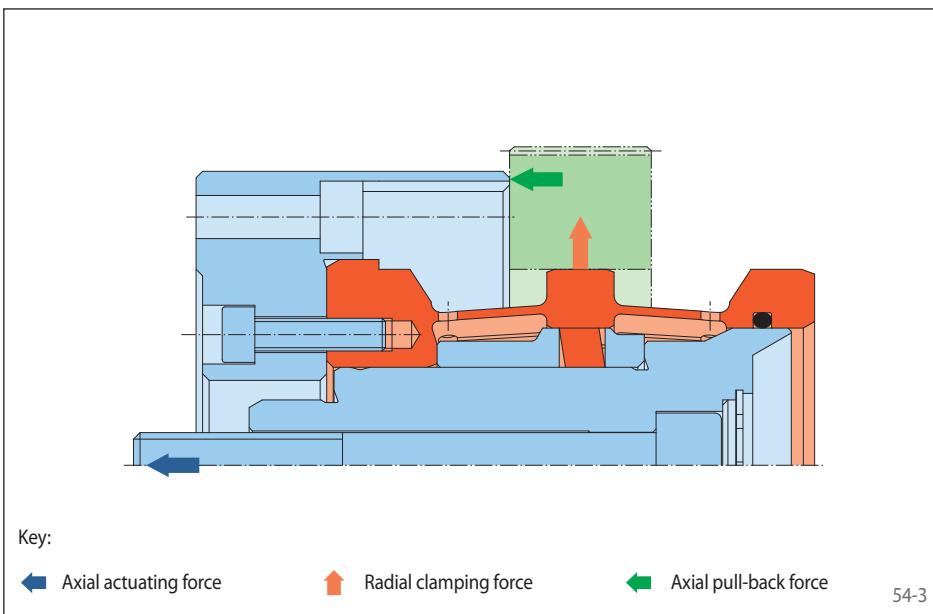

54-3

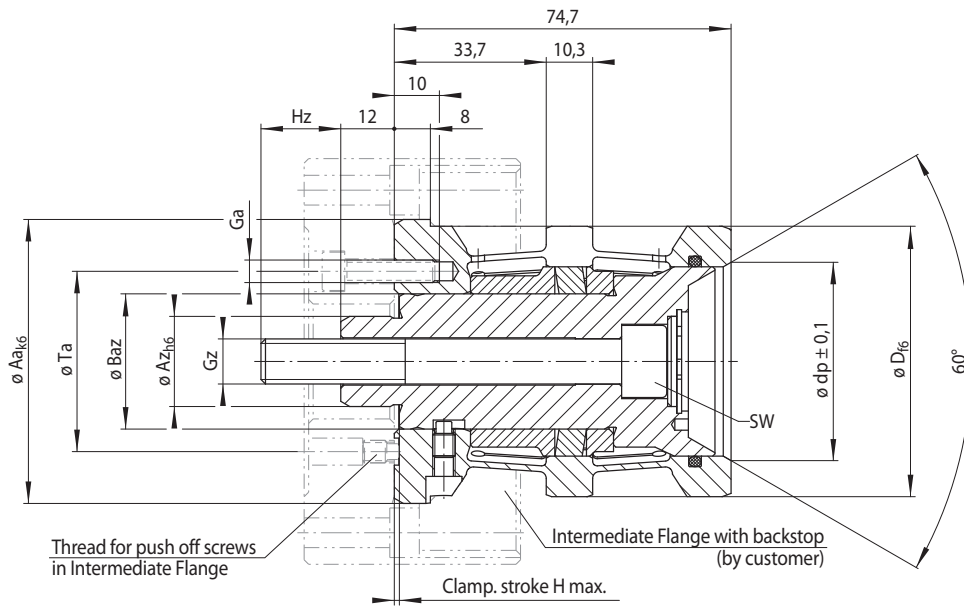

Please note

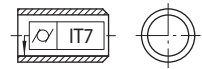

55-1

Size	Clamping range D mm	Maximum diameter change* ΔD mm	Max. transmissible torque** M Nm	Max. actuating force F kN	Tightening torque M_A Nm	Aa mm	Az mm	Baz mm	Bzs mm	dp mm	Ga*** mm	Gz mm	H max. mm	Hz mm	SW mm	Ta mm	Y****	Z*****	Hole pattern
HDDS 11	25,00 - 32,50	0,10	22	3,2	2,7	33	11	11	5	20,8	M 4	M 5	0,3	8,5	4	24	6	2	1
HDDS 15	32,00 - 42,50	0,10	28	4,5	4,5	43	15	15	5	24,3	M 4	M 6	0,6	7,2	5	24	6	2	1
HDDS 20	42,00 - 52,50	0,15	77	7,2	9,6	53	15	20	6	34,3	M 5	M 8	1,0	17,0	6	30	6	3	2
HDDS 30	52,00 - 62,50	0,15	120	10,4	17,0	63	20	30	6	44,0	M 5	M 10	1,0	17,7	8	40	8	4	3
HDDS 40	62,00 - 72,50	0,15	158	10,3	20,2	73	20	40	6	54,0	M 5	M 12	1,0	17,1	10	50	8	4	3
HDDS 50	72,00 - 82,50	0,15	205	11,4	22,2	83	30	50	6	65,0	M 6	M 12	1,0	17,7	10	60	6	3	4

* of the clamping diameter of the Clamping Element.

** The max. transmissible torque refers to the min. clamping diameter. For larger clamping diameters, the max. transmissible torque can be linearly extrapolated with the clamping diameter.

*** for screws of strength class 10.9

**** Y = Number of threaded holes Ga on pitch circle diameter Ta

***** Z = Number of counterbores Bzs on pitch circle diameter Ta, depth of counterbore 1 mm

Pattern of fixing threads and counterbores for push off screws (View from the left)

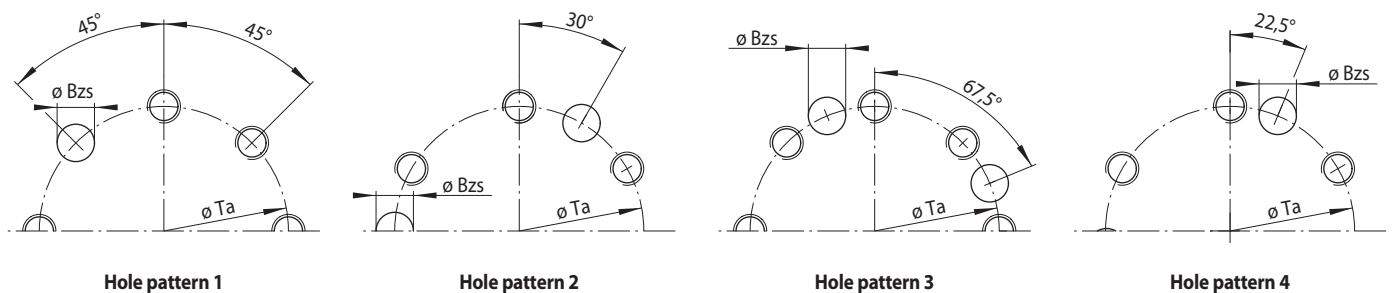

Example for ordering

Please indicate the size of the Clamping Fixture and the clamping diameter of your component, including component tolerance, in your order:

Size: HDDS 20
 Clamping diameter: 42,50 mm
 Component tolerance: H7
 ➔ HDDS 20-42,50H7

Clamping Clutches SKDZ

for printing rollers in printing presses
spring activated - pneumatically released

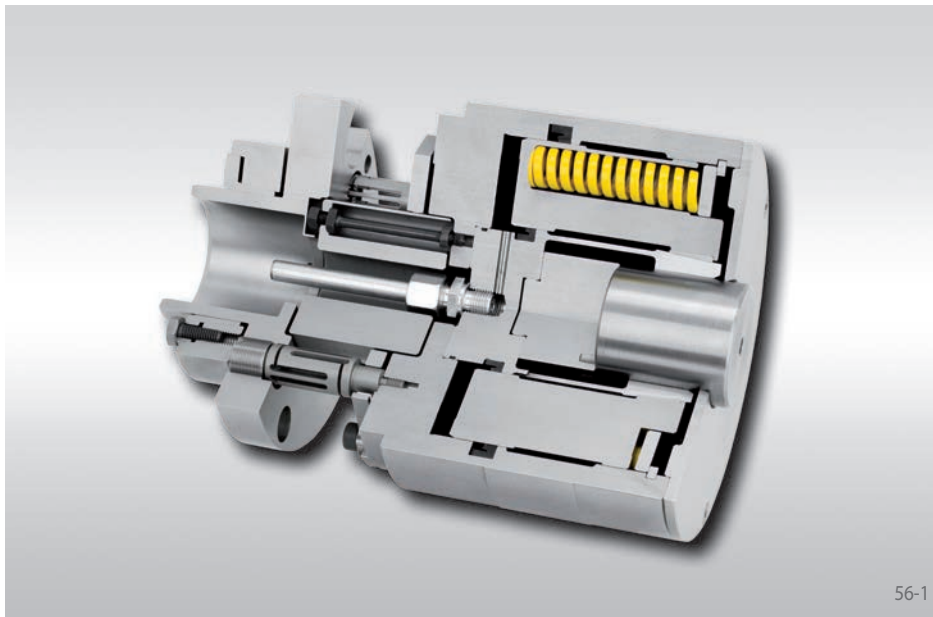

Features

- For clamping diameters from 40 mm to 70 mm
- High true running accuracy
- High torsional rigidity
- High axial rigidity
- Extended insertion depth
- Compensation up to 0,5 mm for radial misalignment
- Compensation for angular misalignment

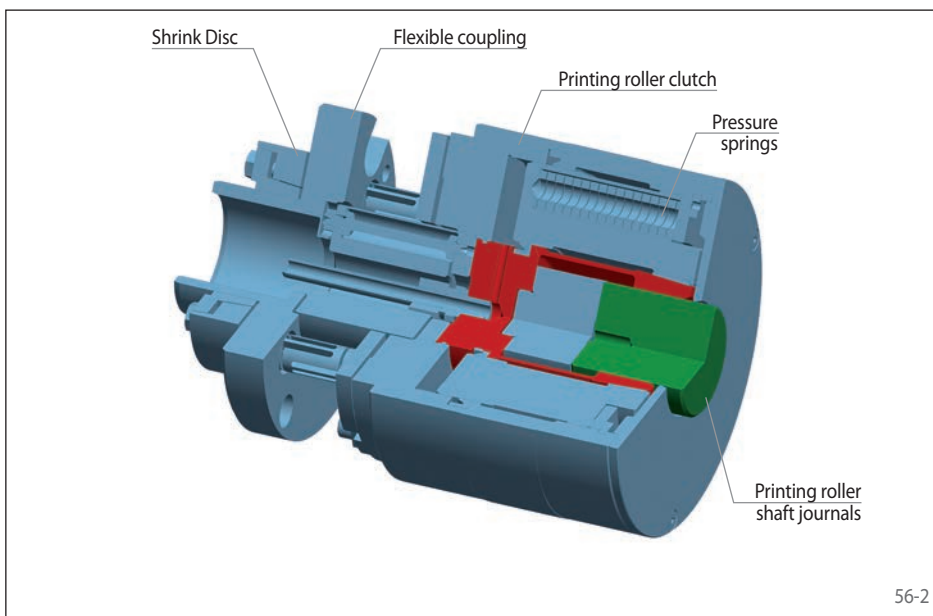

Configuration

The Clamping Clutch for printing rollers in printing presses consists of the printing roller clutch, a flexible coupling connected by a Shrink Disc to the output shaft of gear. The flexible coupling compensates for radial and angular misalignment vis-à-vis the position of the printing roller while maintaining the torsional and axial rigidity required to ensure acceptable printing quality.

The printing roller clutch is released by pneumatic pressure. When it is released, the printing roller is engaged. When pneumatic pressure is removed, the printing roller clutch closes and clamps the printing roller shaft journal without pull-back action. The printing roller clutch is aligned with the axis of the fixed printing roller.



Advantages

- For rapid changes and precise clamping of printing rollers in printing presses in gravure and flexographic printing
- Reduces setup costs and facilitates flexible production with short cycle times
- Reliable slip-free drive power transmission
- Balanced, thus smoother running at high speeds

Clamping Clutches SKDZ

RINGSPANN®

for printing rollers in printing presses
spring activated - pneumatically released

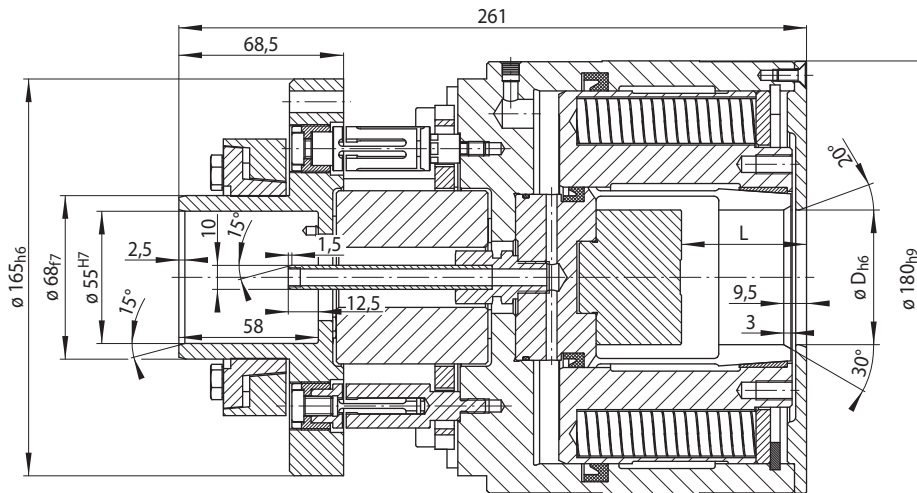

57-1

Type	Clamping range D		ΔD mm	Insertion depth L		Transmissible torque Nm	Transmissible axial force N	Necessary release pressure bar
	min. mm	max. mm		min. mm	max. mm			
SKDZ 10	40	60	0,7	47	62	280	± 4000	15
SKDZ 20	> 60	70	0,7	47	62	280	± 8000	15

Example for ordering

Please indicate the size of your Clamping Clutch, the clamping diameter of your printing roller, including tolerance, and the insertion depth L in your order:

Size: SKDZ 10
Clamping diameter: 50 mm
Tolerance: h6
Insertion depth: 45 mm

➔ SKDZ 10-50h6-45

Maximum speed in rpm

Clamping Clutches may be used up to a max. speed of 1000 min⁻¹.

Hydraulically released

Other Clamping Clutches, e.g. with hydraulically released, are available upon request.

Intermediate Flanges Z ...

for machine connections in accordance to DIN 55026 Form A

Description

Intermediate Flanges are used as adapters between machine connections in accordance to DIN 55026, sizes A5, A6 or A8 (see the machine connection table) and the RINGSPANN Complete Clamping Fixtures.

Possible combinations are listed in the table below. Accordingly, a given Intermediate Flange can be used for different Complete Clamping Fixtures.

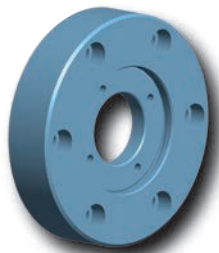

Intermediate Flange type A

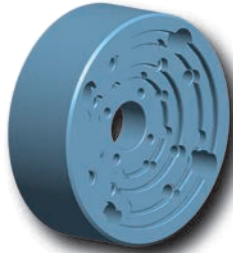

Intermediate Flange type C

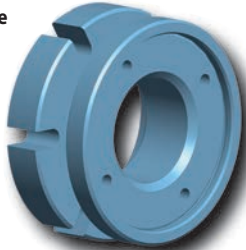

Intermediate Flange type B

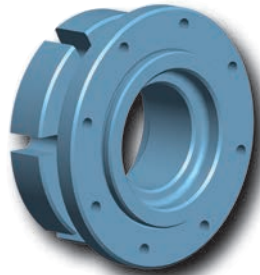

Intermediate Flange type P

58-1

Centring	Intermediate Flange Z			for machine connections in accordance to DIN 55026			for Complete Clamping Fixtures								
	Type	Size	for size Aa* mm	Size A5	Size A6	Size A8	Bonded Disc Pack		Taper Collet		Taper Sleeve		Flat Element		
							Flange Chuck	Flange Mandrel	Flange Chuck	Flange Mandrel	Flange Chuck	Flange Mandrel	Flange Chuck	Flange Mandrel	
at outside diameter Aa	A	70	70	✓	✓	✓		LBDF 11		BKDF 6 BKDF 7 BKDF 12 BKDF 18					
		90	90		✓	✓	LAFF 22 LAFF 32	LBDF 15 LBDF 20 LBDF 25	BKFF 35	BKDF 19 BKDF 27		HKDF 4 HKDF 6 HKDF 7 HKDF 12			
		120	120			✓	LAFF 42	LBDF 30 LBDF 35 LBDF 40 LBDF 45	BKFF 44 BKFF 56	BKDF 32	HKFF 40 HKFF 45 HKFF 50	HKDF 19			
	B	90	90	✓			LAFF 22 LAFF 32	LBDF 15 LBDF 20 LBDF 25	BKFF 35	BKDF 19 BKDF 27		HKDF 4 HKDF 6 HKDF 7 HKDF 12			
		120	120	✓	✓		LAFF 42	LBDF 30 LBDF 35 LBDF 40 LBDF 45	BKFF 44 BKFF 56	BKDF 32	HKFF 40 HKFF 45 HKFF 50	HKDF 19			
		140	140	✓	✓	✓	LAFF 52	LBDF 50		BKDF 43 BKDF 44 BKDF 54	HKFF 66 HKFF 76				
	C	70	70 90 120 140	✓	✓	✓	LAFF 22 LAFF 32 LAFF 42 LAFF 52	LBDF 11 LBDF 15 LBDF 20 LBDF 25 LBDF 30 LBDF 35 LBDF 40 LBDF 45 LBDF 50	BKFF 35 BKFF 44 BKFF 56	BKDF 6 BKDF 7 BKDF 12 BKDF 18 BKDF 19 BKDF 27 BKDF 32 BKDF 43 BKDF 44 BKDF 54	HKFF 40 HKFF 45 HKFF 50 HKFF 66 HKFF 76	HKDF 4 HKDF 6 HKDF 7 HKDF 12 HKDF 19			
	in bore diameter Ba	P	160	160	✓	✓	✓	LAFF 62	LBDF 60 LBDF 70	BKFF 79		HKFF 86 HKFF 96	HKDF 30 HKDF 40		
			185	185 200 225	✓	✓	✓	LAFF 80 LAFF 90 LAFF 100	LBDF 80 LBDF 90 LBDF 100	BKFF 110		HKFF 106 HKFF 114 HKFF 124 HKFF 134 HKFF 150	HKDF 60	KFFF 110 KFFF 120 KFFF 130 KFFF 140	KDFD 110 KDFD 120 KDFD 130

* Corresponds to diameter Aa of the Precision Clamping Fixture.

Intermediate Flanges Z ...

for machine connections in accordance to DIN 55026 Form A

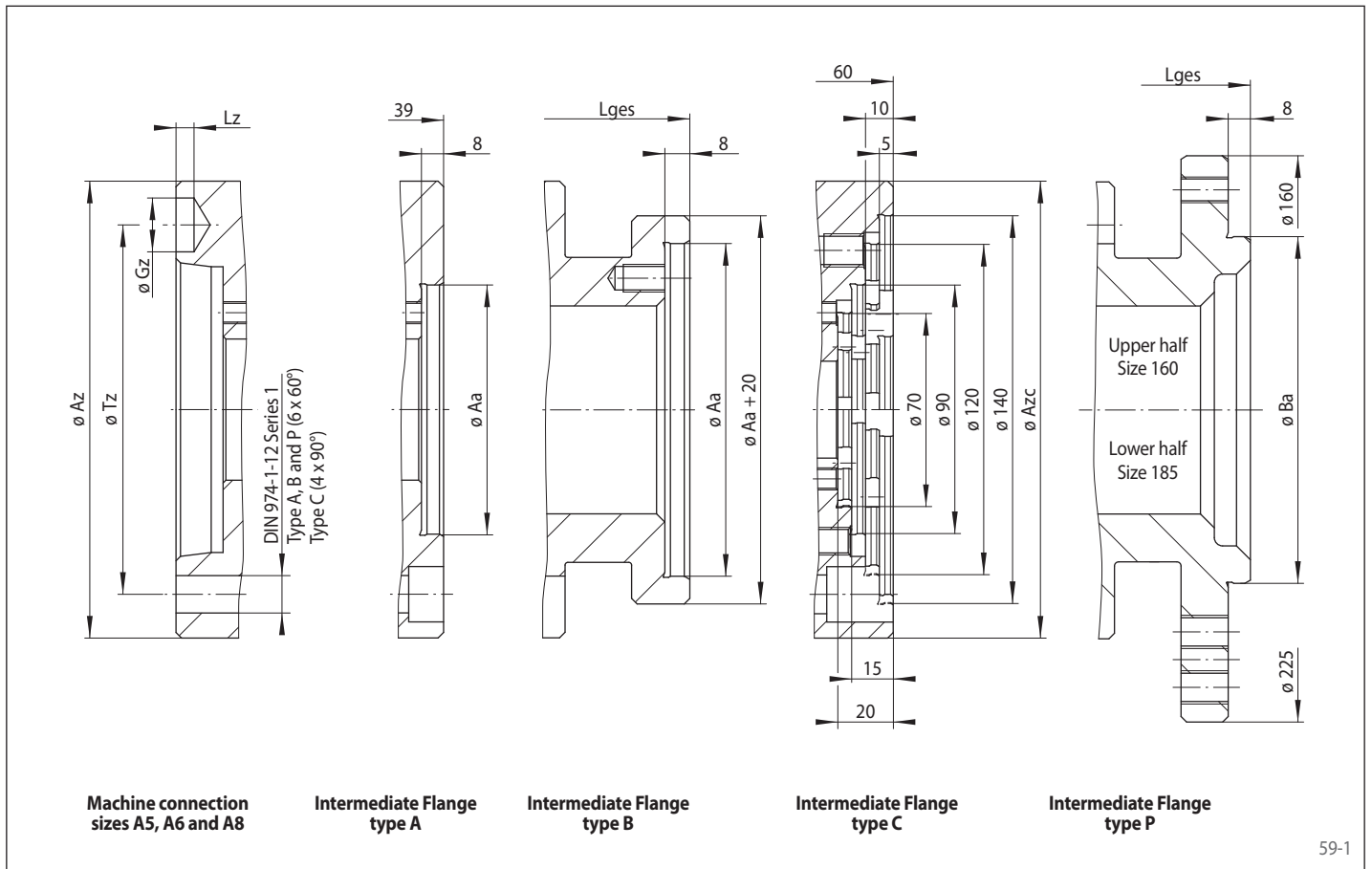

Machine connections in accordance to DIN 55026				
Size	Az mm	Gz mm	Lz mm	Tz mm
A5	135	16,3	6,5	104,8
A6	165	19,45	6,5	133,4
A8	210	24,2	8,0	171,4

Intermediate Flange Z Type B for centring at outside diameter Aa				
Size Aa mm	A5 Lges mm	A6 Lges mm	A8 Lges mm	
90	74			
120	74	75		
140	74	75	81	

Intermediate Flange Z Type P for centring in bore diameter Ba				
Size Aa mm	Ba mm	A5 Lges mm	A6 Lges mm	A8 Lges mm
160	90	74	76	87
185				
200	125	78	80	87
225				

Intermediate Flange Z Type C for centring at outside diameter Aa				
Size	for size Aa mm	A5 Azc mm	A6 Azc mm	A8 Azc mm
70	70 90 120 140	160	165	210

Mounting

We recommend using bolts with strength class 10.9 to mount the Clamping Fixture to the Intermediate Flange and the Intermediate Flange to machine connection.

Example for ordering types A, B and C

Intermediate Flange Z, type C for centring at outside diameter Aa, for machine connections in accordance to DIN 55026 size A8, for size Aa of 120 mm:

- ZCA8 70

Example for ordering type P

Intermediate Flange Z, type P for centring in bore diameter Ba, for machine connections in accordance to DIN 55026 size A6, for size Aa of 185 mm:

- ZPA6 185

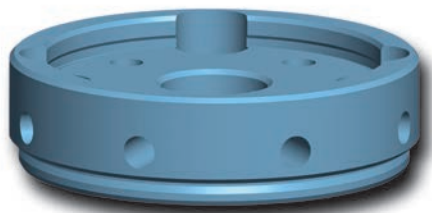

**Intermediate Flange Z
Type D**

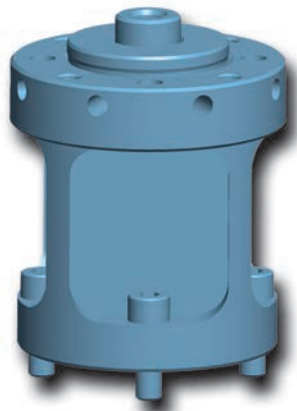

**Spring Force Actuator
FUSR**

Increasingly demanding requirements for balancing accuracy make precise balancing procedures an absolute must.

RINGSPANN Intermediate Flanges for manual clamping and Spring Force Actuators for automated serial production conform to these high standards.

As adapters, they connect the RINGSPANN Precision Clamping Fixture with the balancing machine spindle. The spindle connection conforms to the standard set for Schenck RoTec balancing machines.

60-1

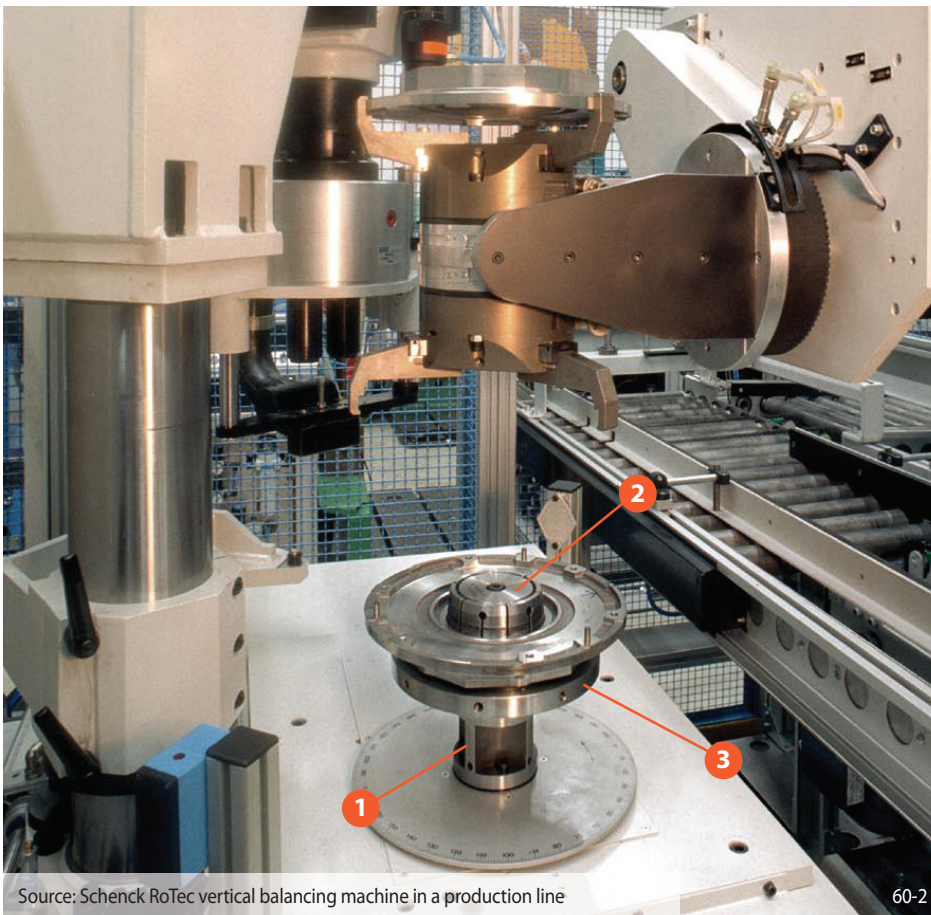

Application example

This example shows the components in use on a Schenck RoTec balancing machine. During the balancing operation, the component remains clamped in place by spring force. To release and change components, the machine-side plunger counteracts the spring force in the idle mode and releases the clamping system.

- ❶ Spring Force Actuator FUSR
- ❷ Taper Collet Flange Mandrel
- ❸ Optional backstop ring

Source: Schenck RoTec vertical balancing machine in a production line

60-2

Intermediate Flanges Z Type D

for manual clamping
for machine connections of balancing machines

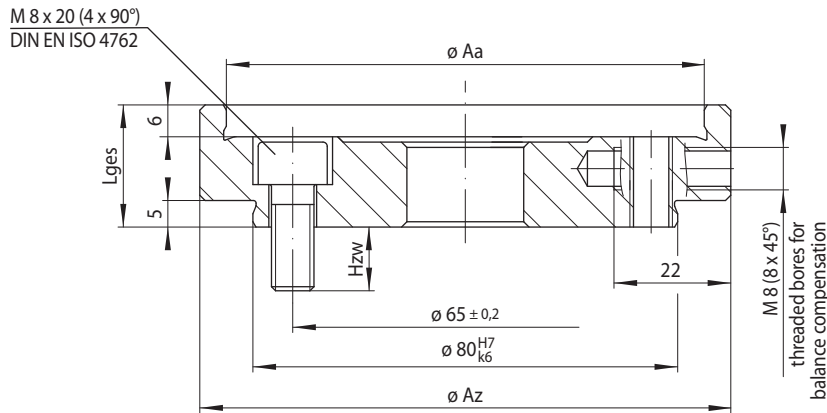

61-1

Intermediate Flange Z		for Complete Clamping Fixtures			Az	Hzw	Lges
Type	Size Aa	Taper Sleeve Flange Chuck	Bonded Disc Pack Flange Mandrel	Taper Collet Flange Mandrel	mm	mm	mm
for centring at outside diameter Aa	D						
	70		LBDF 11	BKDF 6 BKDF 7 BKDF 12 BKDF 18	84	12	23
	90		LBDF 15 LBDF 20 LBDF 25	BKDF 19 BKDF 27	100	12	23
	120		LBDF 30 LBDF 35 LBDF 40 LBDF 45	BKDF 32	130	10	29
	140	HKFF 66 HKFF 76	LBDF 50	BKDF 43 BKDF 44 BKDF 54	150	10	31

Description

Intermediate Flanges Z, Type D connect RINGSPANN Precision Clamping Fixtures to the spindles of balancing machines as adapters.

The component is clamped and released by activating the Precision Clamping Fixture manually. The Intermediate Flange is available in four sizes and is capable of large clamping ranges when supplemented by different Precision Clamping Fixtures.

Eight radial threaded bores are provided for the purpose of balancing the Intermediate Flange with Precision Clamping Fixture. The Intermediate Flange is mounted to the machine with four M 8 bolts.

Example for ordering type D

Intermediate Flange Z, type D for balancing machines (SR), with dimension Aa of 90 mm, for centering Taper Sleeve Flange Mandrel BKDF 27 on outside diameter Aa:

- ZDSR 90-BKDF 27

Spring Force Actuator FUSR

for spring-powered clamping
for balancing machines



Description

Spring Force Actuators FUSR connect RINGSPANN Precision Clamping Fixtures to the spindles of balancing machines as clamping force unit.

The component is clamped by activating the Precision Clamping Fixture with the belleville springs of the Spring Force Actuator. Release is effected via the machine-side plunger, which counteracts the spring force. The Spring Force Actuator is available in five dimensions and is capable of large clamping ranges when supplemented by different Precision Clamping Fixtures.

Eight radial threaded bores are provided for the purpose of balancing the Spring Force Actuator with Precision Clamping Fixtures. The unit is mounted on the machine with four M 8 bolts.

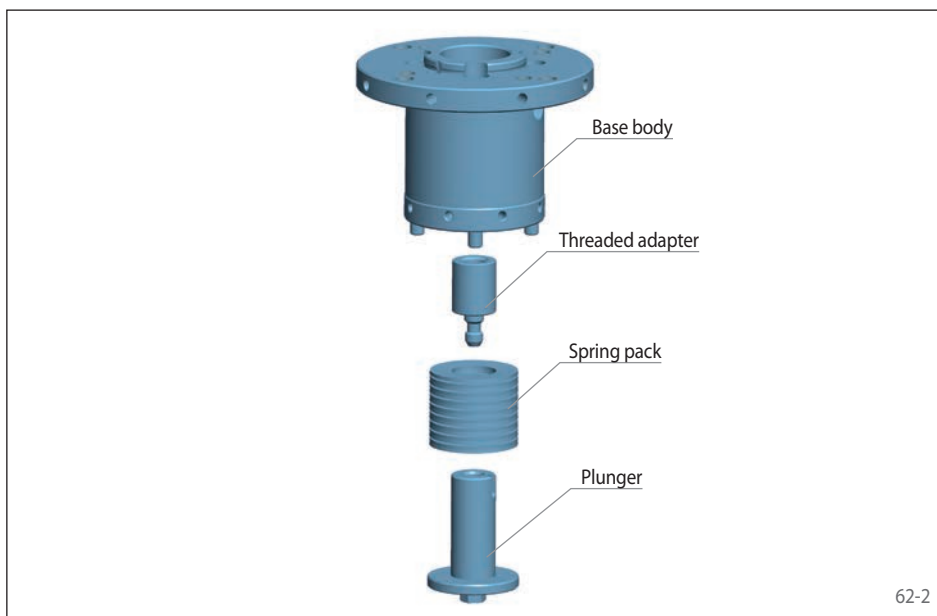

Configuration

The Spring Force Actuator for balancing machines comprises a base body, a spring pack, a plunger and a threaded adapter. Installation is effected via the flange connection of the Spring Force Actuator specifically designed for balancing machines. The Clamping Fixture is activated by spring force and released by the machine-side clamping device, which counteracts the spring force of the Spring Force Actuator via the machine-side plunger.

By exchanging the supplied thread adapters to any size, the connection to the various Precision Clamping Fixtures is made possible, according to the table opposite.

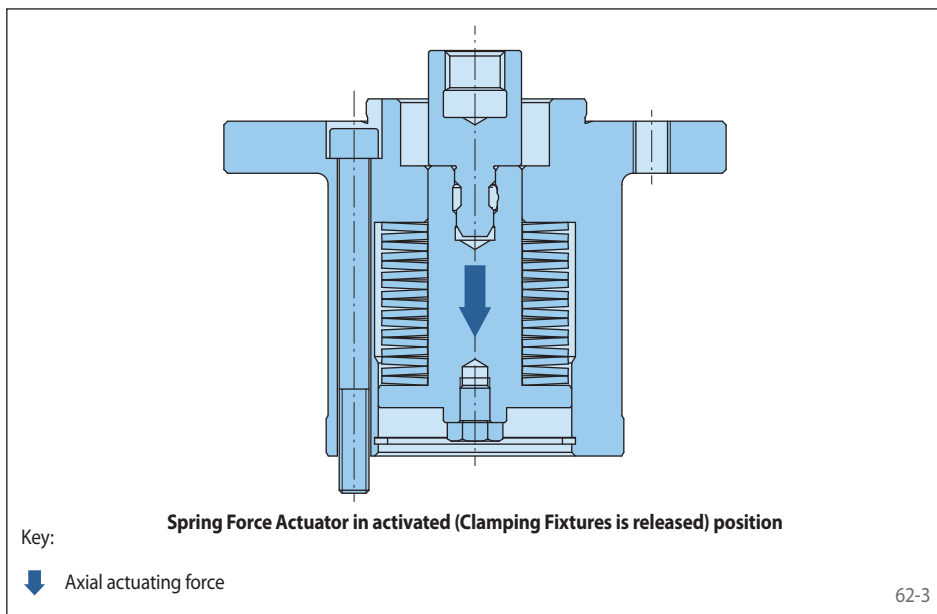

Clamping principle

When the machine-side axial releasing force is removed, the spring force is exerted on the clamping bolt. This moves in the axial direction and activates the Clamping Element of the Clamping Fixtures, which is connected to the clamping bolt.

for spring-powered clamping
for balancing machines

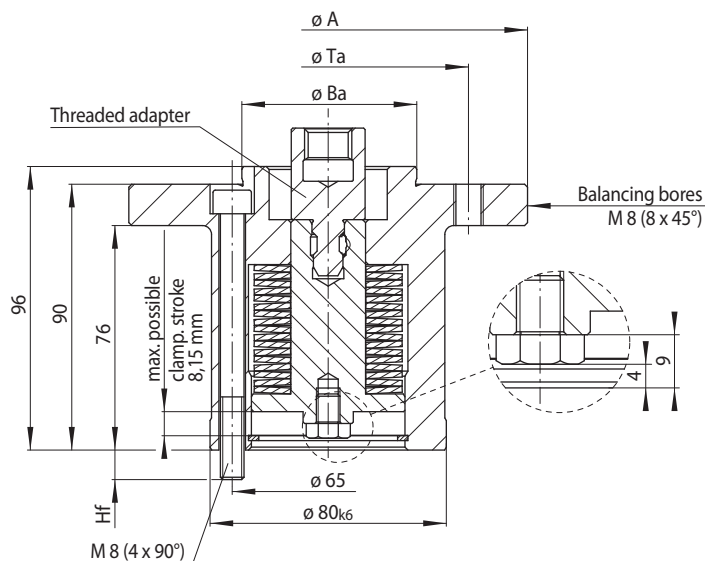

63-1

Spring Force Actuator FUSR for centring in bore diameter Ba						for Complete Clamping Fixtures					
Size	for size Aa* mm	A mm	Ba _{-0,02} mm	Hf mm	Ta mm	Effective clamping force F ^{**}		Taper Collet		Taper Sleeve	
						Clamp. stroke 0 mm min. N	Clamp. stroke 6 mm max. N	Flange Chuck	Flange Mandrel	Flange Chuck	Flange Mandrel
70	70	85	37	10	50	3840	2300		BKDF 6 BKDF 7 BKDF 12 BKDF 18		
90	90	85	50	10	70	3840	2300	BKFF 35	BKDF 19 BKDF 27		HKDF 4 HKDF 6 HKDF 7 HKDF 12
120	120 140	135	60	10	95 115	3840	2300	BKFF 44 BKFF 56	BKDF 32*** BKDF 43*** BKDF 44*** BKDF 54***		HKFF 40 HKFF 45 HKFF 55 HKFF 66 HKFF 76
160	160	160	90	12	135	3840	2300	BKFF 79***			HKFF 86 HKFF 96
185	185 200 225	225	125	12	160 175 200	3840	2300	BKFF 110***			HKFF 106 HKFF 114 HKFF 124 HKFF 134 HKFF 150

* Corresponds to diameter Aa of the Precision Clamping Fixture.

** The effective clamping force and thus the transmissible torque depend on the tolerance of the clamping diameter.

*** When a Spring Force Actuator is in use, the maximum clamping stroke is 6 mm, i.e. maximum diameter change D for Taper Collet Flange Chucks BKFF 79 and BKFF 110 and Taper Collet Flange Mandrels BKDF 32 to BKDF 54 is max. 1.2 mm. To be able to use the other clamping range in each case of the Taper Collet, the use of further adapters is necessary.

Example for ordering Spring Force Actuator

Spring Force Actuator FUSR for balancing machines, size 120, for centering a Taper Sleeve Flange Mandrel BKDF 44 in bore diameter Ba:

- FUSR 120

Example for ordering adapter

Adapter ADFU for Spring Force Actuator FUSR 120 for Complete Clamping Fixtures HKFF 40 with a clamping diameter of 18 mm:

- ADFU 120- HKFF 40-18

Spring Force Actuator and adapter are separate ordering and delivery options.

Note

When using a Spring Force Actuator FUSR, the max. transmissible torque of the Clamping Fixture is reduced according to the Technical points on page 74. This is due to the lower actuating force of the Spring Force Actuator.

Gear wheel for car motorsport gears

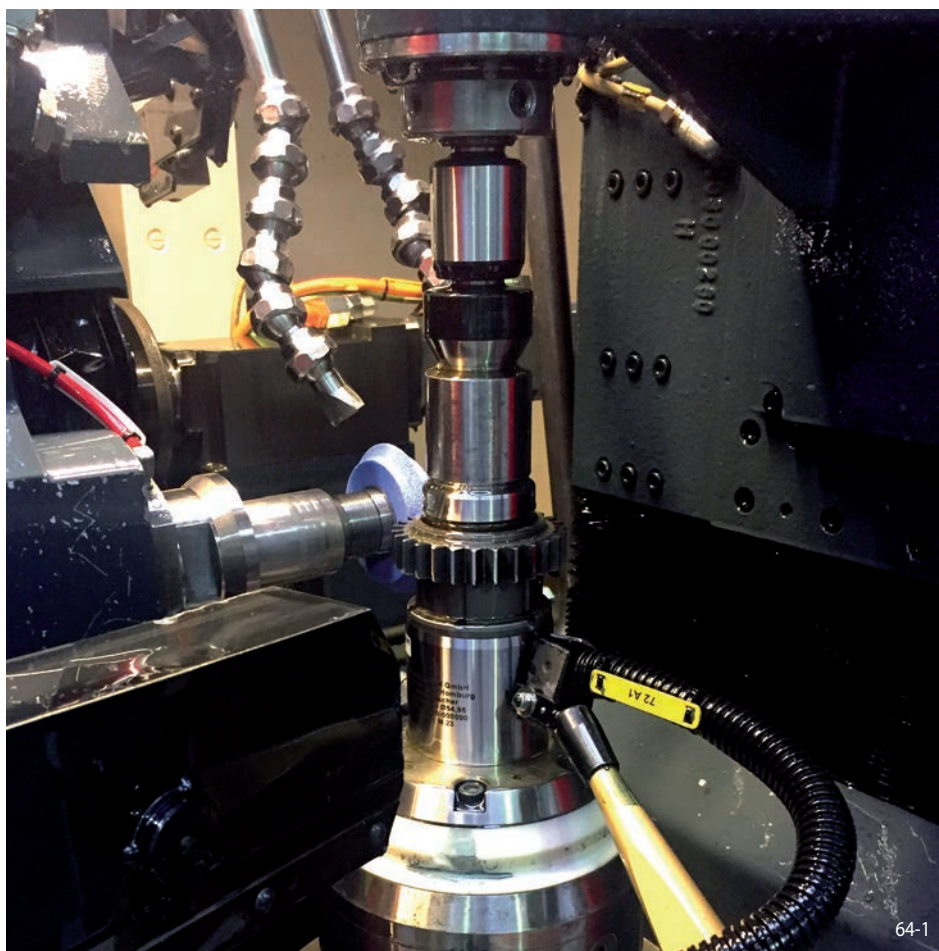

Component

Gear wheel

Type of machine

Grinding machine

Machining

Grinding the gearing

Task

- Clamping with true running accuracy max. 5 µm
- Additional clearance
- Clamping with pull-back action
- Freedom from leakage of the clamping principle
- Hand clamping

Our solution

Expanding Sleeve Mandrel

Clamping principle

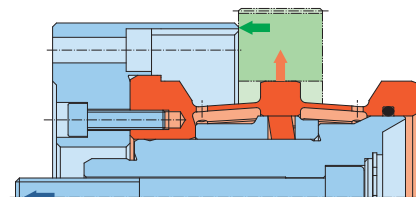

In the manufacturing of customer-specific gear wheels for international motorsports, the highest geometrical accuracy requirements apply. These are significantly higher than the standard quality requirements in normal automotive engineering. Automobile manufacturers for gear wheels expect a high gearing quality of 5 or 4 in accordance with DIN 3961. Volker Schlautmann, head of the RINGSPANN clamping fixture division has therefore come up with a new (and now patented) Expanding Sleeve Mandrel: The HDDS. This innovative inner clamping system is a highly precise and economically attractive alternative to hydraulic expanding clamping tools. It earns plaudits for its true running accuracy of $\leq 5 \mu\text{m}$ and can take workpieces with bores of up to tolerance class IT10. The HDDS significantly reduces the costs for the necessary feeding and positioning technology in fully automated operation.

The man from RINGSPANN presented, with the new Expanding Sleeve Mandrel, to the parent plant of a Swiss specialist for gear wheel. A suitable workpiece had been selected there: A precision spur wheel for the special gear of a sports.

A Höfner Helix 400 grinding centre was used for the machining. Its installation space accommodates a hydraulic base mounting, which the HDDS was clamped into vertically enabling it to be centrally aligned. The gearing engineers then manually clamped a neutral control workpiece in place so as to check the axial run-out accuracy and true running accuracy of the Expanding Sleeve Mandrel with a tactile measuring device accurate to the μm . The result left the audience astonished: The measuring device showed $\leq 2 \mu\text{m}$ for the axial run-out and $\leq 3 \mu\text{m}$ for the true running – amazing accuracies for a mechanical clamping system without additional alignment effort! What precision could then be expected when grinding the gearing?

To find out, a tailstock was mounted. However, its travel distance turned out to have been dimensioned too short to reach RINGSPANN's Expanding Sleeve Mandrel. A spacer had to be used to bridge the gap, although it could not be aligned. Despite this improvisation, the spur wheel blank was now clamped on with the HDDS and the grinding process started.

Surprise on the measuring device

The finished spur wheel was removed from the HDDS and tactile measurements performed on it in a coordinate measuring system. The geometrical accuracy of the involute gearing (the term denotes the force-optimized shaping of the tooth flanks) was well within the tolerance limits. Despite the additional bridging element between the tailstock and the workpiece, only about two thirds of the permissible tolerance was exhausted.

Spurred on by the excellent results achieved until then, the gearing engineers started a further test run, but this time without the tailstock. The new Expanding Sleeve Mandrel then showed its real strength. When grinding without the tailstock since just half of the permitted tolerance had been exhausted. A gearing quality of grade 4 could even be achieved, and without the clamping fixture being realigned!

Gear wheel for car motorsport gears

Higher accuracy at lower costs

With its new Expanding Sleeve Mandrel, RINGSPANN offers a very economical alternative to hydraulic expansion clamping tools. "Apart from the high accuracies achievable with the HDDS, the absolute expansion of our new Expanding Sleeve Mandrel is also up to four times greater. This does not only mean a higher degree of flexibility, but is particularly of great importance for the simple implementation of fully automated manufacturing concepts," Volker Schlautmann says. It is important to mention here that, for pure reasons of physics, hydraulic expanding clamping mandrels have quite a small expansion rate. This requires a high precision from the handling systems used for feeding, which can usually only be achieved with considerable additional investments in measuring and control technology. This problem disappears with the new Expanding Sleeve Mandrel.

Clamping without risk of leakage

A further advantage of the new HDD: Unlike hydraulic clamping systems, it is not subject to a risk of leakage. This offers the user a greater process reliability, since a leak on a hydraulic extension clamping tool always goes hand in hand with malfunctioning, disassembly and repair by the manufacturer. Only the clamping discs – also quality RINGSPANN products – of the Expanding Sleeve Mandrel are subject to minimal wear. These can be exchanged very easily; and the HDDS does not even need to be taken from the machine spindle.

Finally, it should be mentioned that the new inner clamping system from RINGSPANN can also be easily used for workpieces with very short clamping lengths. The Expanding Sleeve Mandrel performs a pull-back action, where the workpiece is pressed against a backstop and ali-

gned – also ensuring an accurate centering and clamping of workpieces with short clamping lengths. Even bores interrupted by a groove for example can be reliably and precisely taken by the HDDS from RINGSPANN without any supplementary aids.

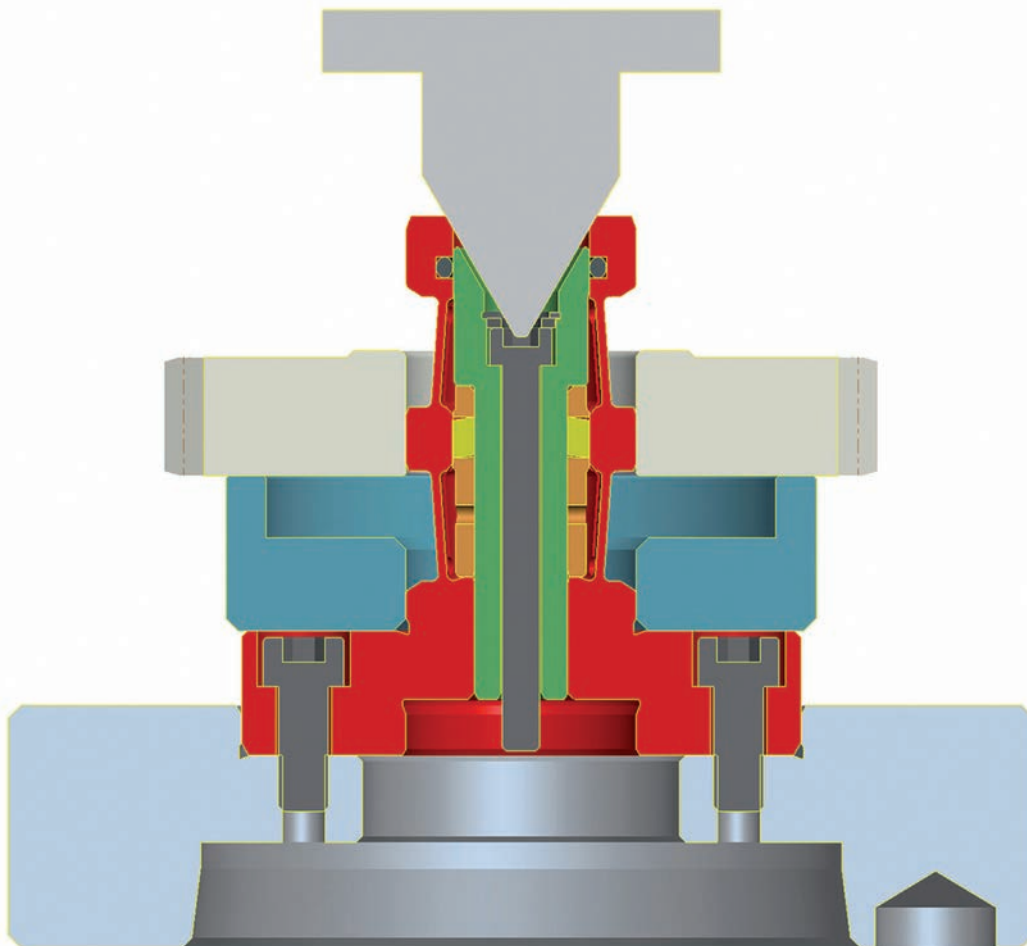

65-1

Truck crown wheel



66-1

Component

Truck crown wheel

Type of machine

Tooth milling machine

Machining

Tooth milling

Task

- Clamping of blank crown gear in the central bore hole
- Automatic loading
- 3 shift serial production
- Quick change to a different clamping diameter

Our solution

- Bonded Disc Pack Flange Mandrel with interchangeable clamping sets and backstop control
- Power activated

Customer benefit

- High clamping precision
- Easy loading due to special loading chamfer on mushroom bush and additional clearance
- Backstop control by air pressure
- Long service life of Bonded Disc Pack
- Interchangeable clamping sets for short set-up time

Brief description

The Bonded Disc Pack Flange Mandrel is equipped with an automatic component feed unit. In order to ensure collision-free loading, the mushroom bush (2) is designed with an insertion chamfer. The additional clearance of approx. 0,2 mm further facilitates loading. During the clamping process, the crown wheel (8) is aligned, pressed against the contact surface and clamped. Radial and axial runout amount to 0,01 mm. Exact flush alignment is monitored by an air-system control unit (9). By changing the replaceable clamping sets consisting of a mushroom bush (2), a seating body (3), a thrust ring (7) and a Bonded Disc Pack (6), the clamping system can be reconfigured quickly for processing of other crown wheel types.

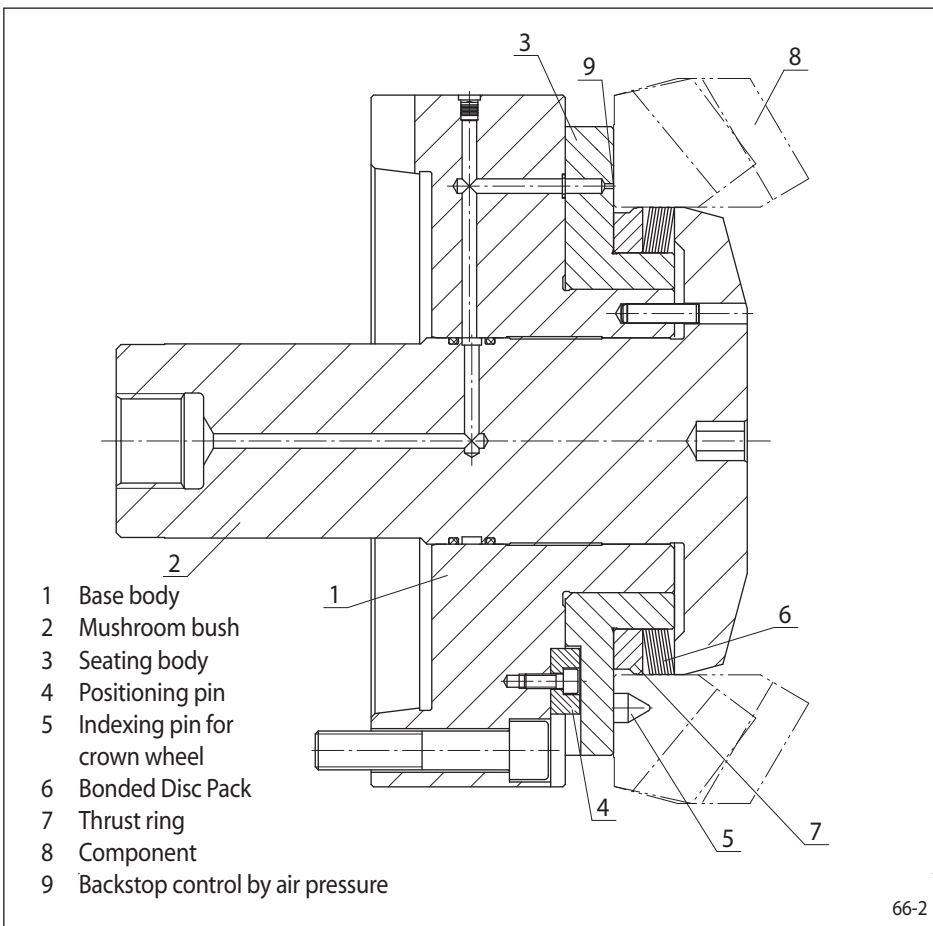

66-2

- 1 Base body
- 2 Mushroom bush
- 3 Seating body
- 4 Positioning pin
- 5 Indexing pin for crown wheel
- 6 Bonded Disc Pack
- 7 Thrust ring
- 8 Component
- 9 Backstop control by air pressure

Clamping principle

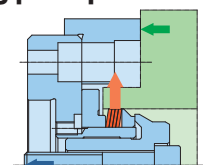

Gear wheel

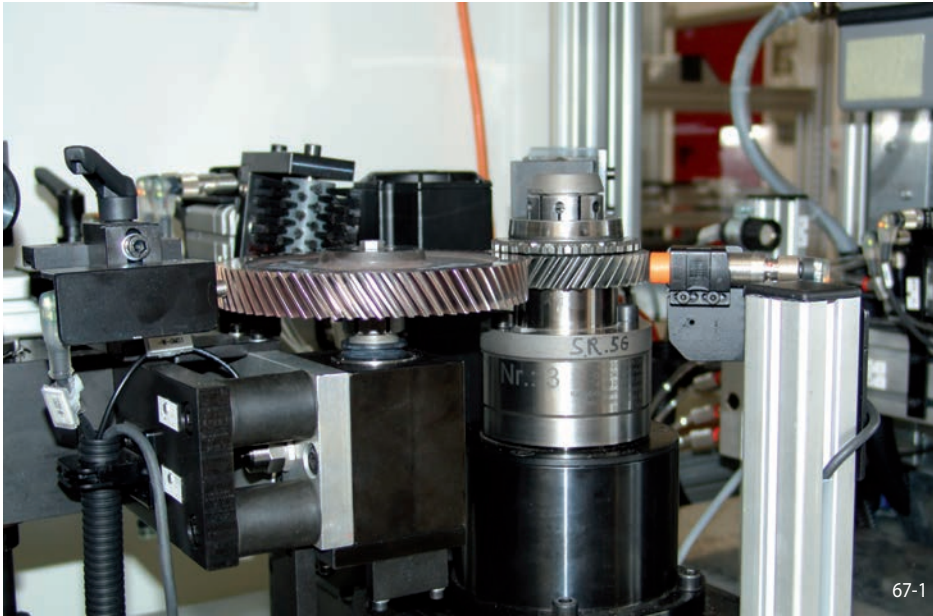

Component

Gear wheel

Type of machine

Testing machine

Machining

Inspection of gear tooth performance

Task

- Clamping of gear wheels during automatic operation
- Transmission of torque during testing
- High true running accuracy

Our solution

- Taper Collet Flange Mandrel
- Power activated

Customer benefit

- Additional clearance (1,2 mm expansion)
- True running accuracy $\leq 0,01$ mm

Brief description

The Taper Collet Flange Mandrel is integrated within a fully automated testing machine. Loading and unloading are effected by a robot. The entire gear wheel is pressed against the master wheel, which drives it. The resulting noise is measured and evaluated. At the same time, geometric scanning and inspection are performed by a laser.

Clamping principle

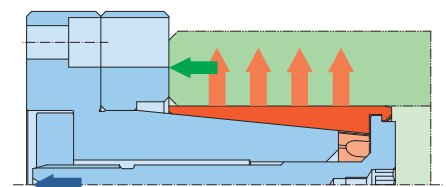
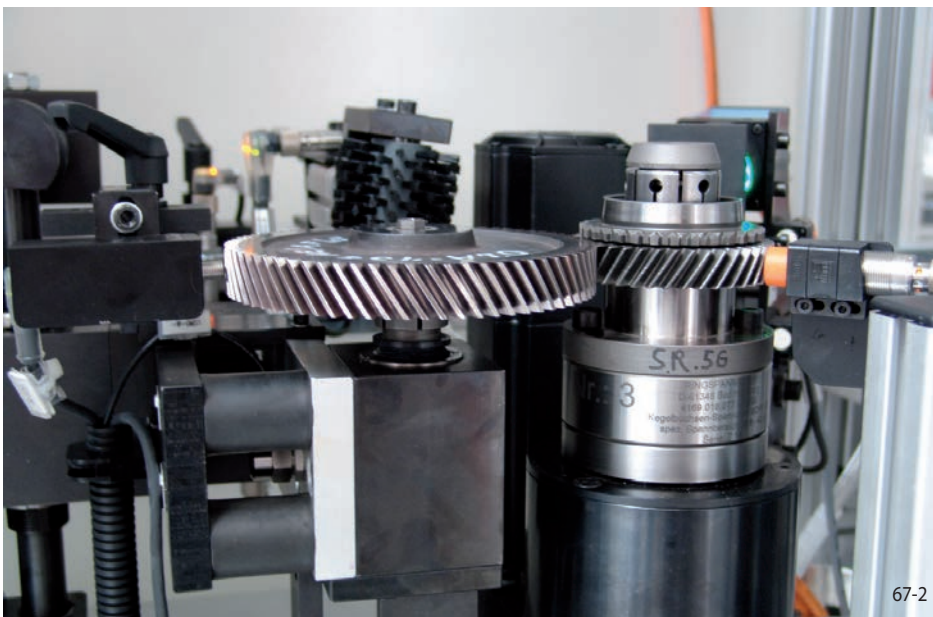

Crown wheel



68-1

Component

Crown wheel

Type of machine

Lapping and testing machine

Machining

Lapping and testing of gear teeth

Task

Clamping of crown wheels with possibility of quick change to different clamping diameters

Our solution

- Expanding Sleeve Mandrel as base seating body
- Bonded Disc Pack Flange Mandrel as interchangeable clamping sets
- Power activated

Customer benefit

- Quick change to different clamping diameters without loss of accuracy
- No precise positioning action necessary as the base seating body remains on the spindle
- One Clamping Fixture for different crown wheels

Brief description

The base seating body (1), configured as an Expanding Sleeve Mandrel, remains permanently in the lapping and testing machine. The Expanding Sleeve Mandrel (1) centres and clamps the various replaceable clamping sets consisting of a base body flange (3), a backstop ring (4), a Bonded Disc Pack (6) and a mushroom cover (5). The force required to clamp the crown wheel (9) is provided by the machine tie rod (2). The mushroom cover (5) engages the Bonded Disc Pack (6), which centres the crown wheel (9), aligns it through pull-back action and clamps it. Axial and radial runout are less than 0,006 mm. The entire replaceable clamping set can be removed for replacement by loosening the radial clamping bolt (7) on the Expanding Sleeve Mandrel (1) and the central bolt on the mushroom cover. The operation can be completed in just a few minutes. Thus this system is also suitable for the economically efficient production of small lots.

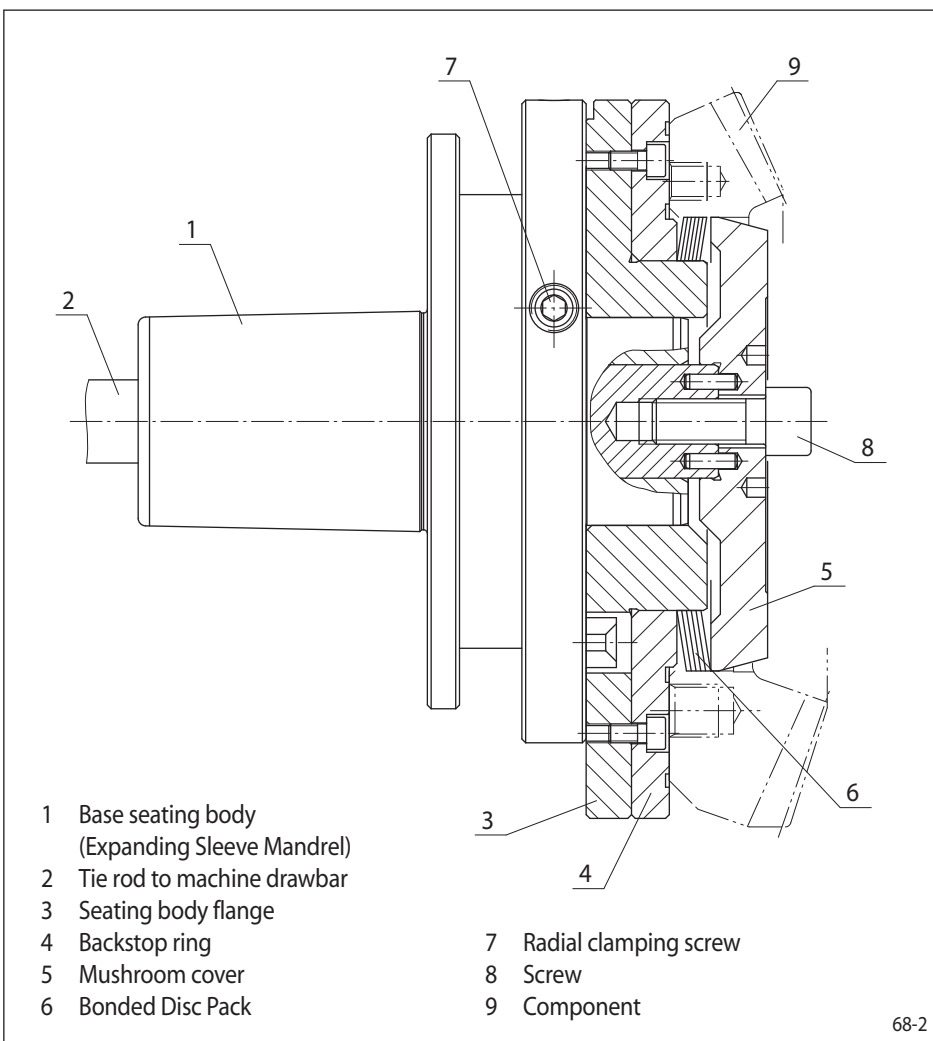

68-2

Clamping principle

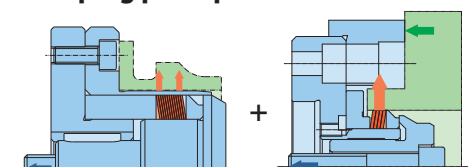

Gear wheel for a wind turbine transmission

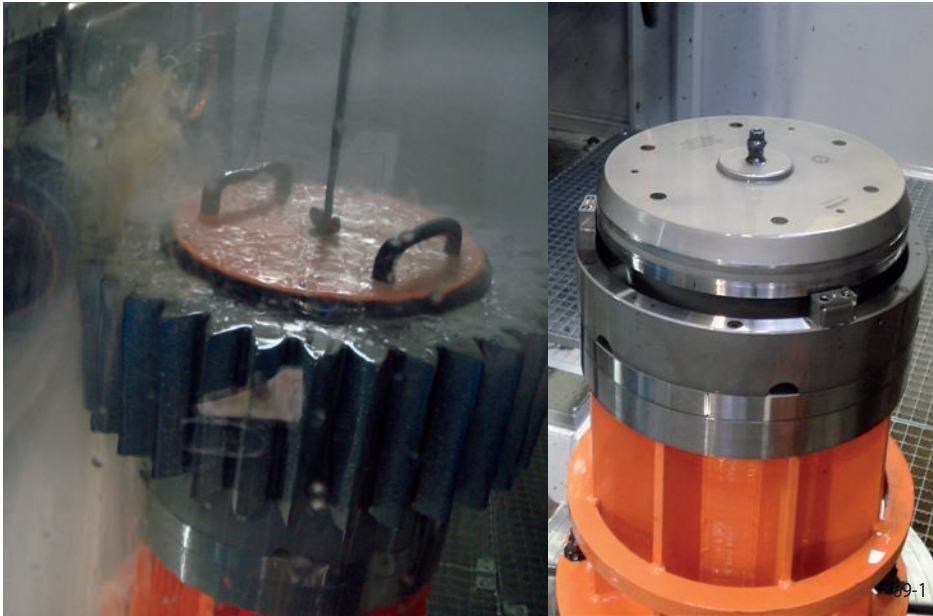

Component

Gear wheel for a wind turbine transmission

Type of machine

Grinding machine

Machining

Grinding of tooth flank

Task

- Central component alignment, max. weight 1 000 kg
- Clamping for machining torque transmission

Our solution

- Flat Element Flange Mandrel
- Power activated

Customer benefit

- Centering accuracy $\leq 0,01$ mm in spite of heavy component weight
- True running accuracy $\leq 0,02$ mm
- Poweractuating with actuating force reduction
- Cover with pre-centring

Brief description

The Clamping Fixture is actuated when pressure is applied. Because the minimal programmable actuating force of the machine is greater than the maximum permissible force for the Flat Element, an actuating force limiter is positioned between the power clamping device of the machine and the thrust bolt of the Flat Element Flange Mandrel. This consists of two telescope sleeves with disc springs positioned in between. The Flat Element Flange Mandrel exerts a very high radial force which securely centres and clamps the gear wheel in spite of its substantial weight. The cover is equipped with an insertion groove, in order to facilitate the loading of heavy components.

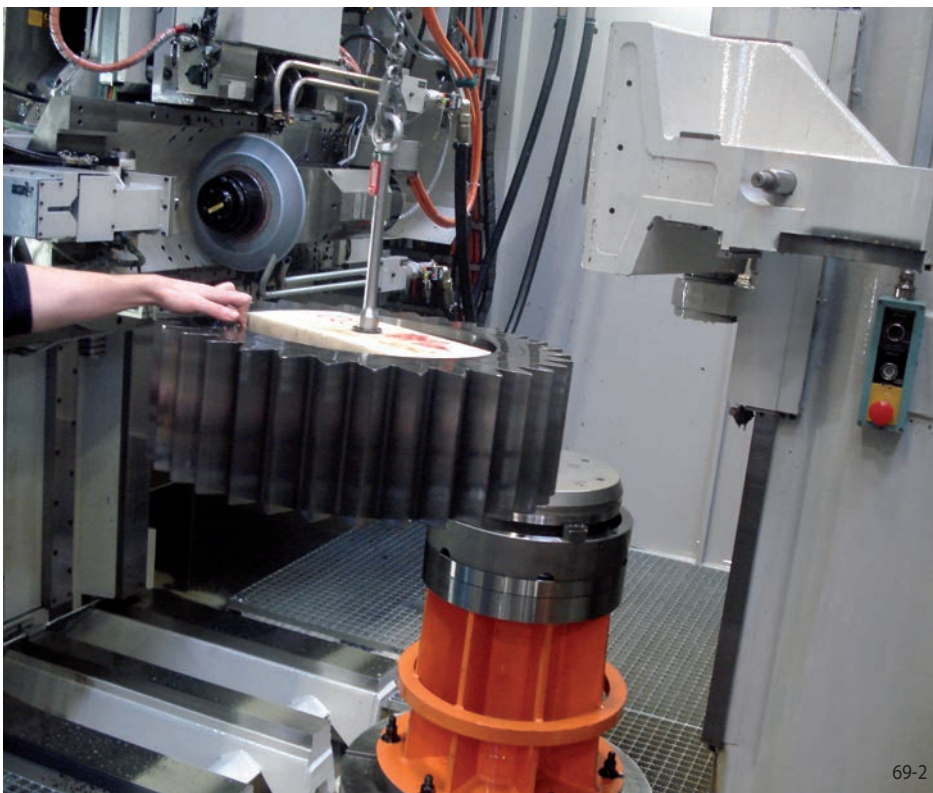

Clamping principle

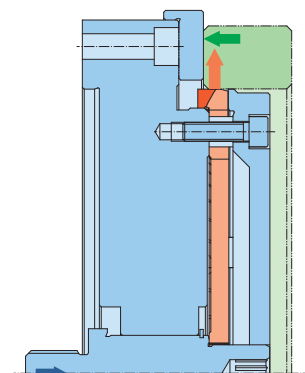



70-1

Component

Forming roller for profile rolling mills

Type of machine

Lathe

Machining

Contour machining

Task

Rework or remanufacturing of form roller

Our solution

- Bonded Disc Pack Clamping Mandrel
- Manually activated

Customer benefit

- Very short set-up time
- High true running accuracy
- Application independent of component length
- Long service life

Brief description

Mounting in the tolerance bores on both sides of the of the form roller (5). The Bonded Disc Pack Clamping Mandrel on the left transmits the torque required for processing. It is held by a precision base chuck. The Bonded Disc Pack Clamping Mandrel on the right is centred with a tailstock pin.

Clamping principle

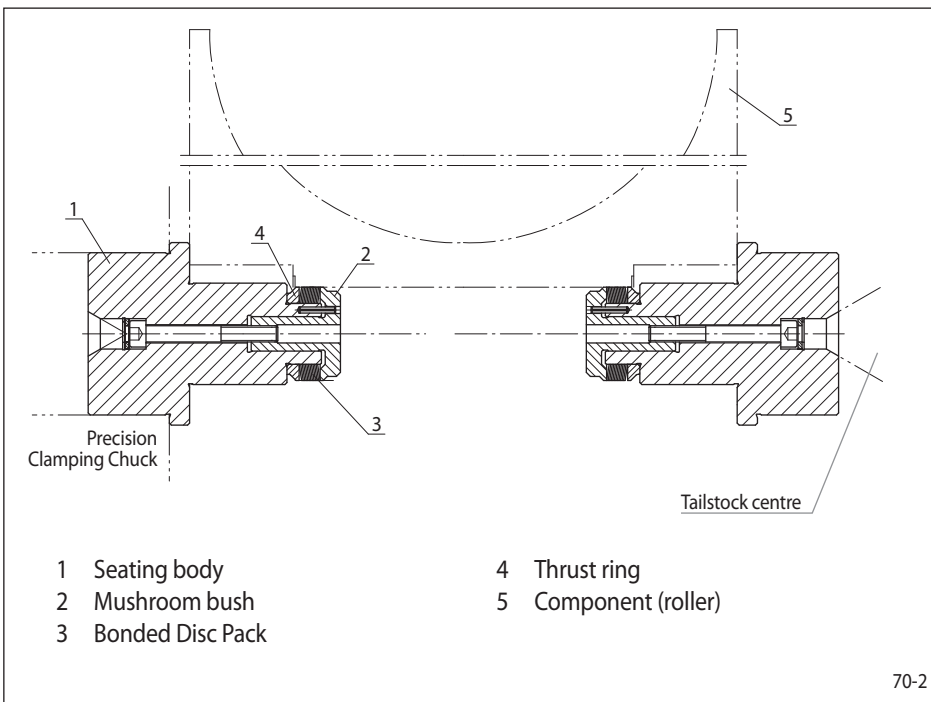

70-2

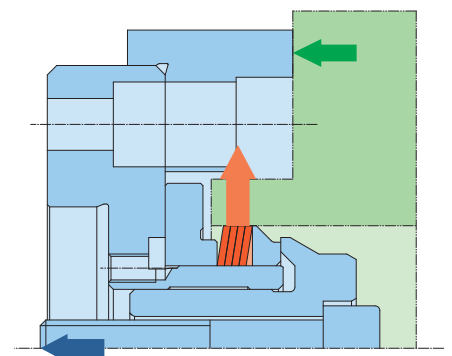

General information

The deployment and ambient conditions for RINGSPANN Clamping Fixtures and Clamping Elements are different for every application. The workpiece itself, with its geometry, hardness, surface quality and the type of the assembly, exert influence on the Clamping Fixture. That is why RINGSPANN cannot provide any informa-

tion on the wear behaviour and, as a result, cannot provide any prediction on the expected service life of the Clamping Fixture and instead only give general maintenance information.

Maintenance and cleaning of the Clamping Fixture should be carried out at the latest when the maintenance of the machine is carried out. More frequent maintenance intervals may become necessary through observation during operation and regular visual inspection e.g. at shift commencement.

Prerequisites for the component to be clamped for the use of RINGSPANN Clamping Fixtures

RINGSPANN Clamping Fixtures require a pre-machined diameter and a pre-machined con-

tact surface. It is hereby assumed that the contact surface and clamping diameter run impact-

free to one another and the diameter to be clamped doesn't have any concentricity errors.

Installation and commissioning

- Clamping Discs, Bonded Disc Packs, Disc Elements, Taper Collets, Taper Sleeves, Flat Elements, Basket Elements or Short Elements are coated with a light coat of oil and pressed onto the seating diameter.

- In the case of Basket Elements, Short Elements and Flat Elements, the Clamping Element must first be pressed with a portion of its circumference into the seating diameter. It is then gradually driven along its entire circumference into the seating diameter by applying careful, inward blows with a rubber hammer.

When installing RINGSPANN Clamping Elements, it is important to ensure that they contact firmly against the entire circumference of the axial backstop.

Maximum true running accuracy is achieved by clamping and releasing the fixture once without a component and then three times with a component after installation and before component processing begins.

No shifting of position on the seating diameter

The Clamping Fixtures must be designed in such a way as to ensure that the Clamping Ele-

ments cannot shift position on the seating diameter either during clamping or during release.

Axial component pull-back

Axial pull-back is required for processing a component in accordance with the true running accuracy specifications set by RINGSPANN. It is important to ensure that the contact surface moves without impact to the the clamping diameter and the component contact to the surface with the maximum possible diameter. In

order to prevent soiling, the backstop ring surfaces should be as narrow as possible or unslotted. If backstop pins are used, they must be ground without axial and radial runout.

In the event that "runout" cannot be restricted through constructive measures, clamping must

be effected at two centring points positioned as far apart as possible. We recommend using a cardanic ring (pendle ring) as a backstop. Maximum possible true run accuracy of Clamping Fixtures cannot be achieved with ball discs and bevel socket washers in accordance with DIN 6319 as moving backstops.

Maximum permissible speeds

RINGSPANN Clamping Fixtures, except for Basket Element Clamping Chucks (1 000 rpm), are suitable for tool machines with a speed of

up to 3 500 rpm. If a higher speed is envisaged, please contact us.

Sealing, chip removal

Rubberized RINGSPANN Clamping Elements (except for Taper Collets) are protected against the ingress of chips and dirt. In the case of

vertically positioned chucks, cavities and bores for complete chip removal must be provided.

Verification of selected Clamping Elements

Transmissible torque, required actuating force, specific pressure

The required actuating forces for the selected Clamping Elements are calculated in this section. Actuating forces F , F_o or F_m and F_{on} or F_{mn} for transmission of the maximum possible torques M , M_1 and M_n are shown in the table. These maximum forces may not be exceeded.

The following apply to Clamping Discs:

$$M = n \cdot M_1 \text{ [Nm]}$$

$$F_o = n \cdot F_{o1} \text{ [N]}$$

$$F_m = n \cdot F_{m1} \text{ [N]}$$

n = number Clamping Discs (max. 16)

If the actuating forces are lower than the maximum forces, transmissible torque M is reduced and the specific pressure between the Clamping Element and the component is reduced proportionally (down to half of catalogue values). This may be necessary in cases involving

- thin-walled components,
- soft materials,
- sensitive components surfaces and
- slotted component clamping surfaces.

Axial holding force

The axial holding force F_{ax} is derived from the catalogue values of "transmissible torque M " and "clamping diameter D ".

$$F_{ax} \text{ [N]} = \frac{M \text{ [Nm]} \cdot 1\,000 \text{ [mm/m]}}{D/2 \text{ [mm]}}$$

Clamping accuracy

If all functional surfaces of a Clamping Fixture are free of radial and axial runout, the achievable true run accuracy is:

- up to clamping diameter of 300 mm: 0,01 mm (0,005 mm centre misalignment),
- over a clamping diameter of 300 mm: 0,02 mm (0,01 mm centre misalignment).

If greater accuracy is required, all Clamping Fixture components (and possibly the Clamping Element) must be prevented from twisting. The following procedure must be employed:

1. Alignment of the Clamping Fixture on the machine spindle with the aid of a master component. Radially adjustable setting screws should be provided as alignment aids.
2. In the case of fixtures with rigid centring, both the slightly pre-loaded Clamping Elements and the axial contact surfaces must be lightly ground to the exact clamping diameter.

Dimension control

Due to their elasticity, dimension control of RINGSPANN Clamping Elements that have not been installed is not possible. Dimension control cannot be performed until the Clamping Fixture has been assembled, as the Clamping Elements are pre-loaded.

Rubber coating

The Bonded Disc Packs LAF, LHF, LBD and LID, as well as all standard Clamping Elements HKF, HKD, KFF, KFD and HDDS, are generally rubber-coated. All other Clamping Elements can be rubber-coated in the slots according to the customer's wishes (exception BKF). Exempted from

a rubber coating are through-holes for back-stop pins.

The rubber is elastic; however, it takes on the new form with the increasing duration of a deformation during clamping (clamping relaxation). This can lead to the Clamping Element not

immediately fully returning to its original position when opening the Clamping Element. The clearance for insertion is then reduced and the removal of the workpiece or the assembly with a new workpiece is potentially made more difficult.

Life (service life) of Clamping Elements

The service life of RINGSPANN Clamping Elements is limited by the nature of its use. The Clamping Element can only hold 500 parts or still work without issue after three million workpieces. This depends on the wear, ultimately on

the workpiece to be clamped, its hardness, surface quality, the automation components and the processing. In principle, the workpiece slowly abrades the clamping surfaces of the Clamping Elements. Ultimately, the wear de-

gree can only be examined by the machine operator via a regular inspection of the diameters at the Clamping Element in relaxed and fully clamped state.

Multiple clamping points

Engineering design and the calculation of forces and torques for Clamping Fixtures with two or more clamping points are very complex.

We recommend having such Clamping Fixtures produced entirely by RINGSPANN. Please send us the completed questionnaire on page 78.

for Clamping Elements for Spring Force Actuator

Material and hardness

Clamping Fixtures are made of case-hardened steel for maximum effectiveness. Components which come in contact with Clamping Elements are inserted and hardened:

- Hardness rating HRc 62 ± 2
- Hardening depth after grinding 0,5 mm

Required transmissible machining torques

The actual machining torques to be transmitted must be specified by the customer.

In balancing operations, the mass moment of inertia during accelerating/braking (emergency cutoff) is the crucial factor.

Clearance for insertion / Machines with automatic component loading features

The Clamping Elements are realised as follows:

Chuck clamping

The maximum dimension of the workpiece clamping diameter corresponds to the nominal diameter of the Clamping Element that has an E7 tolerance.

Mandrel clamping

The minimum dimension of the workpiece clamping diameter corresponds to the nominal diameter of the Clamping Element that has an E6 tolerance.

Tolerances E7 and e6 result in a minimum clearance for insertion that is adequate for manual assembly.

In case of automatic assembly, the centering accuracy of the handling unit during the assembly process must be taken into consideration. In addition to increased loading clearance a pre-guiding must be provided, if necessary, under no circumstances may there be any contact of component and clamping element while loading / unloading. Please pay special attention to sealing and chip removal.

The catalogue contains information on the maximum change in diameter ΔD. for the respective Clamping Elements. As an additional clearance for insertion, this value can be realised minus the difference between the maximum and minimum dimensions of the clamping diameter at the workpiece. In this case, we ask you to specify the workpiece clamping diameter, the tolerance and the additional clearance for insertion to be taken into consideration.

Machine connection and actuating

The actuating forces and tightening torques for hand clamping listed in the tables describe the load limit of the Clamping Element and must not be exceeded.

If the force exerted by the actuating device cannot be reduced below the load limit of the Clamping Element, two constructive possibilities can be realized to reduce the actuating force applied to the Clamping Element:

1. Actuating force with spring washer pack:

The required actuating force is applied with spring washers. The power clamping unit is used to release the Clamping Fixture by pressing the spring washers together and thus reducing the actuating force. When using rubberized Clamping Elements it is important to ensure that they are always stored or shut down after the completion of work with relaxed Clamping Elements or with clamped components (or control rings) in order to prevent relaxation of the rubber covering on the Clamping Elements.

2. Reducing the actuating force with an intermediate spring washer pack:

In this possibility, the actuating force is reduced and applied by an intermediate spring washer pack.

The values for actuating forces (longitudinal forces) and transmissible torques listed in the tables are virtually proportional.

Note for calculation of the max. transmissible torque of the Spring Force Actuator FUSR

When using a Spring Force Actuator FUSR, the max. transmissible torque of the Clamping Fixture is reduced. This is due to the lower actuating force of the Spring Force Actuator.

Clamping Chuck

$$M_{th} = \frac{F_f \cdot M_{max} \cdot D}{F_{max} \cdot D_{max}} \text{ [Nm]}$$

Clamping Mandrel

$$M_{th} = \frac{F_f}{F_{max}} \cdot M_{max} \text{ [Nm]}$$

Definition of terms used in these equations:

D = Clamping diameter of the component [mm]

D_{max} = max. clamping diameter of the Clamping Fixture size [mm]

M_{max} = max. transmissible torque of the Clamping Fixture size [Nm]

M_{th} = max. transmissible torque of the Spring Force Actuator [Nm]

F_f = min. spring force of the Spring Force Actuator [N]

F_{max} = max. actuating force of the Clamping Fixture size [N]

for Bonded Disc Packs and Clamping Discs

Guide length

In order to achieve a uniform enlargement or reduction of the clamping diameter around the entire circumference, a guide length of $L \geq 0,7 \times D$ must be ensured for guide bushes, mushroom bushes, differential clamping bushes and intermediate bushes. D is the clamping diameter of the RINGSPANN Clamping Disc. In the case of Clamping Chucks, the actuating force can be achieved with a threaded ring. The threading on the chuck body and on the threaded ring must be free of play and runout against the functional surfaces. Achievable true run accuracy is much lower when threaded rings are used, however.

hes and intermediate bushes. D is the clamping diameter of the RINGSPANN Clamping Disc. In the case of Clamping Chucks, the actuating force can be achieved with a threaded ring. The threading on the chuck body and on the threaded ring must be free of play and runout against the functional surfaces. Achievable true run accuracy is much lower when threaded rings are used, however.

ded ring must be free of play and runout against the functional surfaces. Achievable true run accuracy is much lower when threaded rings are used, however.

No chamfers and radii

The transition from the seating diameter to the contact surface for RINGSPANN Bonded Disc Packs or Clamping Discs must have a sharp edge (1) without rounding and without undercuts. This can be achieved by employing a sharp-edge ring, e.g. shoulder ring that covers the undercut.

The part that is pressed flat by the RINGSPANN Bonded Disc Packs or Clamping Discs, e.g. thrust ring during clamping must also have a

runout-free ground circumferential sharp edge (2) in order to ensure that the entire circumference is pressed uniformly flat.

Fitting tolerances

Parts which slide against each other are produced with a fit tolerance of H7/h6. All parts must be checked for ease of movement. In order to avoid fit play, moveable bushes in or on which RINGSPANN Clamping Elements are seated must fit without clearance or in counter components. Thin-walled bushes can be deformed by pressure exerted by RINGSPANN Clamping Discs. Potential clamping can be prevented by free rotation inside the play-free glide surfaces in the seat area of the RINGSPANN Clamping Discs. In the case of Clamping Mandrels and Clamping Chucks, all diameters to which the

component leads must be designed in accordance with the grinding dimension plus the to-

lerance (e6 or E7) of the Clamping Element.

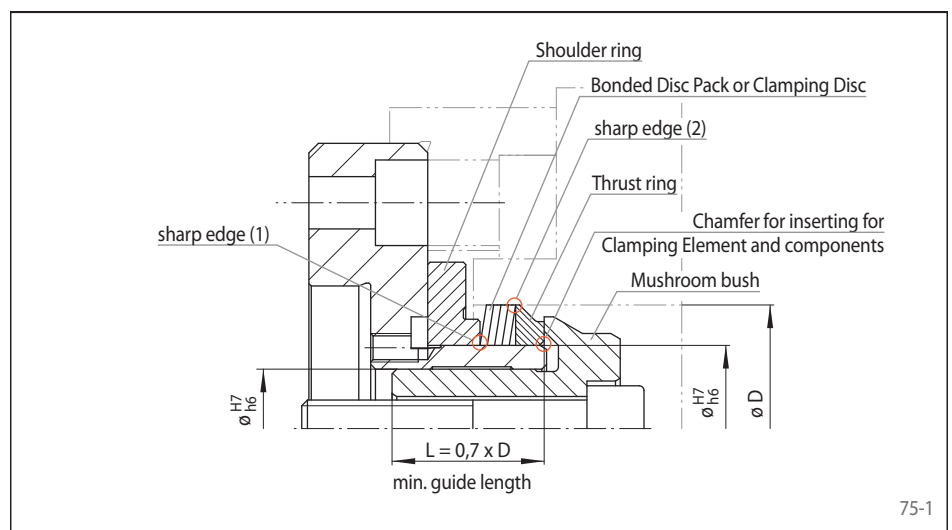

No inadvertent expanding

When mounting components, it is essential to ensure that inadvertent expanding of the Bonded Disc Packs or Clamping Discs is avoided. Such expanding may be caused by impact of the component against the thrust ring or the

mushroom bush. This problem applies especially to automatic loading systems. In this case, we advise against using thrust rings and special mushroom bushes (for mandrel clamping) and draw bushes (for chuck clamping). In the re-

leased position these special bushes must be held in axial position by the power clamping system, by springs or by other suitable means.

Maximum number of discs per pack

In the case of Clamping Disc packs with a large number of Clamping Discs, the Clamping Discs farthest from the source of axial force play only a reduced role in force transmission.

A useful simplified rule is that discs in excess of a total of 16 contribute only about 50% to force transmission. Therefore, a number of discs must be added which is equivalent to calculated

number of discs in excess of 16. Disc packs with more than 25 discs should be avoided.

Thrust rings

Thrust rings are have been finished with the same diameter and the same tolerance as RINGSPANN Clamping Discs and Bonded Disc Packs.

for Bonded Disc Packs and Clamping Discs

Transmissible torque, required actuating force

Parallel Bonded Disc Pack Clamping Fixtures

Parallel Bonded Disc Pack Clamping Fixtures grip the component at multiple clamping points of the same diameter. Bonded Disc Packs of equal thickness are used for this purpose. The total sum of all individual actuating forces exerted by the Bonded Disc Packs is required to actuate the Clamping Fixture. The total transmissible torque is equal to the sum of the transmissible torques of the Bonded Disc Packs.

Please consult with us with regard to configurations consisting of more than two Bonded Disc Packs.

Series Bonded Disc Pack Clamping Fixtures

Series Bonded Disc Pack Clamping Fixtures have two clamping points of equal diameter for gripping two identical components. The faces of both components must be in a parallel plane and runs without an error to the clamping diameter. When both components are clamped, both clamping points must be clamped in succession. This is achieved with the use of two disc packs of different thickness. The Bonded Disc Pack with the lower actuating force represents the actuating force of the Clamping Fixture. The thicker Bonded Disc Pack is clamped with the same actuating forces as the thinner Bonded Disc Pack. The simple transmissible torque of the thinner Bonded Disc Pack is applied to each clamping point.

Differential Bonded Disc Pack Clamping Fixtures

Differential Bonded Disc Pack Clamping Fixtures grip the component at two clamping points, which may have different diameters. When clamping the component, as with Series Bonded Disc Pack Clamping Fixtures, the individual clamping points are clamped in succession. This is achieved with the use of two Bonded Disc Packs of different thickness. The Bonded Disc Pack with the lower actuating force represents the actuating force of the Clamping Fixture and contributes its full catalogue torque to torque transmission. The thicker Bonded Disc Pack is clamped with the same actuating force as the thinner Bonded Disc Pack. The total transmissible torque of the clamping device is calculated as follows in units equipped with **an anti-twist lock** for the moveable seat of the broad Bonded Disc Pack.

$$M = M_I + M_{IIred} = M_I + M_{II} \frac{F_{mI}}{F_{mII}} \quad [Nm]$$

Definition of terms used in this equation:

- F_{mI} = required actuating force of the thinner Bonded Disc Pack
- F_{mII} = required actuating force of the thicker Bonded Disc Pack
- M_I = maximum transmissible torque of the thinner Bonded Disc Pack
- M_{IIred} = transmissible torque of the thicker Bonded Disc Pack at reduced actuating force F_{mI}
- M_{II} = maximum transmissible torque of the thicker Bonded Disc Packs

Tolerances

Basic tolerances

Nominal dimensional range over ... to mm	Basic tolerance degrees															
	IT1	IT2	IT3	IT4	IT5	IT6	IT7	IT8	IT9	IT10	IT11	IT12	IT13	IT14	IT15	IT16
	Basic tolerance μm											mm				
to 3	0,8	1,2	2,0	3	4	6	10	14	25	40	60	0,10	0,14	0,25	0,40	0,6
3 ... 6	1,0	1,5	2,5	4	5	8	12	18	30	48	75	0,12	0,18	0,30	0,48	0,75
6 ... 10	1,0	1,5	2,5	4	6	9	15	22	36	58	90	0,15	0,22	0,36	0,58	0,9
10 ... 18	1,2	2,0	3,0	5	8	11	18	27	43	70	110	0,18	0,27	0,43	0,70	1,1
18 ... 30	1,5	2,5	4,0	6	9	13	21	33	52	84	130	0,21	0,33	0,52	0,84	1,3
30 ... 50	1,5	2,5	4,0	7	11	16	25	39	62	100	160	0,25	0,39	0,62	1,00	1,6
50 ... 80	2,0	3,0	5,0	8	13	19	30	46	74	120	190	0,30	0,46	0,74	1,20	1,9
80 ... 120	2,5	4,0	6,0	10	15	22	35	54	87	140	220	0,35	0,54	0,87	1,40	2,2
120 ... 180	3,5	5,0	8,0	12	18	25	40	63	100	160	250	0,40	0,63	1,00	1,60	2,5
180 ... 250	4,5	7,0	10,0	14	20	29	46	72	115	185	290	0,46	0,72	1,15	1,85	2,9
250 ... 315	6,0	8,0	12,0	16	23	32	52	81	130	210	320	0,52	0,81	1,30	2,10	3,2
315 ... 400	7,0	9,0	13,0	18	25	36	57	89	140	230	360	0,57	0,89	1,40	2,30	3,6
400 ... 500	8,0	10,0	15,0	20	27	40	63	97	155	250	400	0,63	0,97	1,55	2,50	4,0
500 ... 630	9,0	11,0	16,0	22	32	44	70	110	175	280	440	0,70	1,10	1,75	2,80	4,4
630 ... 800	10,0	13,0	18,0	25	36	50	80	125	200	320	500	0,80	1,25	2,00	3,20	5,0
800 ... 1000	11,0	15,0	21,0	28	40	56	90	140	230	360	560	0,90	1,40	2,30	3,60	5,6
1000 ... 1250	13,0	18,0	24,0	33	47	66	105	165	260	420	660	1,05	1,65	2,60	4,20	6,6
1250 ... 1600	15,0	21,0	29,0	39	55	78	125	195	310	500	780	1,25	1,95	3,10	5,00	7,8

Limits for selected tolerance ranges

Nominal dimension mm	E7 μm	F7 μm	H7 μm	e6 μm	f7 μm	h6 μm
to 3	+24	+16	+10	-14	-6	0
over 3	+14	+6	0	-20	-16	-6
to 6	+20	+10	0	-28	-22	-8
over 6	+40	+28	+15	-25	-13	0
to 10	+25	+13	0	-34	-28	-9
over 10	+50	+34	+18	-32	-16	0
to 18	+32	+16	0	-43	-34	-11
over 18	+61	+41	+21	-40	-20	0
to 30	+40	+20	0	-53	-41	-13
over 30	+75	+50	+25	-50	-25	0
to 50	+50	+25	0	-66	-50	-16
over 50	+90	+60	+30	-60	-30	0
to 80	+60	+30	0	-79	-60	-19
over 80	+107	+71	+35	-72	-36	0
to 120	+72	+36	0	-94	-71	-22
over 120	+125	+83	+40	-85	-43	0
to 180	+85	+43	0	-110	-83	-25
over 180	+146	+96	+46	-100	-50	0
to 250	+100	+50	0	-129	-96	-29
over 250	+162	+108	+52	-110	-56	0
to 315	+110	+56	0	-142	-108	-32
over 315	+182	+119	+57	-125	-62	0
to 400	+125	+62	0	-161	-119	-36
over 400	+198	+131	+63	-135	-68	0
to 500	+135	+68	0	-175	-131	-40
over 500	+215	+146	+70	-145	-76	0
to 630	+145	+76	0	-189	-146	-44
over 630	+240	+160	+80	-160	-80	0
to 800	+160	+80	0	-210	-160	-50
over 800	+260	+176	+90	-170	-86	0
to 1000	+170	+86	0	-226	-176	-56

Excerpt from VDI 2230, Page 1, issue of February 2003

Dimension	Assembly pretensioning force F_{MTab} in kN for $\mu_G = 0,12$			Tightening torques M_A in Nm for $\mu_K = \mu_G = 0,12$		
	Property classes			Property classes		
	8.8	10.9	12.9	8.8	10.9	12.9
M 4	4,4	6,5	7,6	3,0	4,6	5,1
M 5	7,2	10,6	12,4	5,9	8,6	10,0
M 6	10,2	14,9	17,5	10,1	14,9	17,4
M 7	14,8	21,7	25,4	16,8	24,7	28,9
M 8	18,6	27,3	32,0	24,6	36,1	42,2
M 10	29,6	43,4	50,8	48	71	83
M 12	43,0	63,2	74,0	84	123	144
M 14	59,1	86,7	101,5	133	195	229
M 16	80,9	118,8	139,0	206	302	354
M 18	102	145	170	295	421	492
M 20	130	186	217	415	592	692
M 22	162	231	271	567	807	945
M 24	188	267	267	714	1017	1190

Assembly pre-loading force F_{MTab} and tightening torques M_A at $v = 0,9$. For shaft screws with standard metric threading in accordance with DIN ISO 262. Head dimensions of hex screws in accordance with DIN EN ISO 4014 - 4018, socket hex screws in accordance with DIN 34800 and cylinder screws in accordance with DIN EN ISO 4762 and "medium" bore as defined in DIN EN 20273. • μ_G = thread, μ_K = screw head

Please photocopy or use the PDF-File from our website!

Company: Address: Phone: Fax:	Department: Name: Enquiry Ref.: Date: E-mail:
--	---

1. Component	Please send us your component drawing showing the following details: 1. Which surfaces are to be machined? (Please indicate in drawing) 2. Clamping diameter with tolerance: 3. Which end surface can be used as an axial backstop? (Please indicate in drawing) 4. Component loaded in: <input type="checkbox"/> by hand <input type="checkbox"/> automated	5. Permissible TIR between clamping diameter and machined diameters: 6. Material: 7. Hardened: <input type="checkbox"/> Yes <input type="checkbox"/> No 8. Number to be machined per year: 9. Does the backstop surface run true in relation to the clamping diameter? <input type="checkbox"/> Yes <input type="checkbox"/> No
---------------------	--	---

2. Function	1. Clamping tool is intended for: <input type="checkbox"/> Turning <input type="checkbox"/> Boring <input type="checkbox"/> Milling <input type="checkbox"/> Grinding <input type="checkbox"/> Balancing <input type="checkbox"/> Checking <input type="checkbox"/> 2. Max. Speed: min ⁻¹	3. How many tools are engaged simultaneously? (Please enter in the component drawing and mark tools I, II, etc.) <table border="1" style="margin-left: auto; margin-right: auto; border-collapse: collapse; text-align: center;"> <thead> <tr> <th style="padding: 5px;">Tool</th> <th style="padding: 5px;">I</th> <th style="padding: 5px;">II</th> </tr> </thead> <tbody> <tr> <td style="padding: 5px;">Cutting Depth (mm)</td> <td style="width: 40px; height: 20px;"></td> <td style="width: 40px; height: 20px;"></td> </tr> <tr> <td style="padding: 5px;">Feed (mm/U)</td> <td style="width: 40px; height: 20px;"></td> <td style="width: 40px; height: 20px;"></td> </tr> </tbody> </table>	Tool	I	II	Cutting Depth (mm)			Feed (mm/U)		
Tool	I	II									
Cutting Depth (mm)											
Feed (mm/U)											

3. Machine	1. Type of machine: 2. Component axis: <input type="checkbox"/> horizontal <input type="checkbox"/> vertical 3. Clamping fixture mounting: <input type="checkbox"/> between centres <input type="checkbox"/> flange mounted <input type="checkbox"/> taper mounted 4. Tailstock: <input type="checkbox"/> Yes <input type="checkbox"/> No 5. Standard designation of spindle flange, mounting taper: or drawing of spindle head, if necessary with connecting dimensions for pull or pushrod.	6. Max. load capacity of the spindle: kg 7. Adjustment range of power clamping fixture: pull from N to N push from N to N 8. Clamping actuation: <input type="checkbox"/> by central nut or screw (manual clamping) <input type="checkbox"/> through the hollow machine spindle (power actuating by connecting with machine drawbar) <input type="checkbox"/> by tailstock pressure <input type="checkbox"/> by a central spring pack <input type="checkbox"/> actuating piston implemented into Clamping Fixture <input type="checkbox"/> 9. Which coolant do you use:
-------------------	---	--

4. Requirements	Quantity required:
------------------------	--------------------------

5. Enclosure	Component drawings, spindle head drawings, others:
---------------------	--

Germany

RINGSPANN GmbH

Schaberweg 30-38, 61348 Bad Homburg
Germany • +49 6172 275 0
info@ringspann.de • www.ringspann.de

RINGSPANN RCS GmbH

Hans-Mess-Straße 7, 61440 Oberursel, Germany
+49 6172 67 68 50
info@ringspann-rcs.de • www.ringspann-rcs.de

France

SIAM - RINGSPANN S.A.

23 rue Saint-Simon, 69009 Lyon, France
+33 4 78 83 59 01
info@siam-ringspann.fr • www.ringspann.fr

Great Britain, Ireland

RINGSPANN (U.K.) LTD.

3, Napier Road, Bedford MK41 0QS, Great Britain
+44 1234 3425 11
info@ringspann.co.uk • www.ringspann.co.uk

Italy

RINGSPANN Italia S.r.l.

Via A.D. Sacharov, 13, 20812 Limbiate (MB), Italy
+39 02 93 57 12 97
info@ringspann.it • www.ringspann.it

Netherlands, Belgium, Luxembourg

RINGSPANN Benelux B.V.

Nieuwenkampsdijk 6-15, 7472 DE Goor,
Netherlands • +31 547 26 13 55
info@ringspann.nl • www.ringspann.nl

Austria, Hungary, Slovenia

RINGSPANN Austria GmbH

Triesterstraße 21, 2620 Neunkirchen, Austria
+43 2635 62446
info@ringspann.at • www.ringspann.at

Poland

Radius-Radpol Wiecheć Sp.J.

Ul. Pasjonatów 3, 62-070 Dąbrowa, Poland
+48 61 814 39 28 • info@radius-radpol.com.pl
www.radius-radpol.com.pl

Romania, Bulgaria, Moldova

S.C. Industrial Seals and Rolls S.R.L.

Str. Depozitelor, No. 29, 110078 Pitesti, Romania
+4 0751 228228
mihai@isar.com.ro • www.isar.com.ro

Sweden, Finland, Denmark,

Norway, Baltic states

RINGSPANN Nordic AB

Flottiljgatan 69, 721 31 Västerås, Sweden
+46 156 190 98
info@ringspann.se • www.ringspann.se

Switzerland

RINGSPANN AG

Sumpfstrasse 7, P.O. Box, 6303 Zug,
Switzerland • +41 41 748 0900
info@ringspann.ch • www.ringspann.ch

Spain, Portugal

RINGSPANN IBERICA S.A.

C/Uzbina, 24-Nave E1, 01015 Vitoria, Spain
+34 945 2277-50
info@ringspann.es • www.ringspann.es

Czech Republic, Slovakia

Ing. Petr Schejbal

Mezivřší 1444/27, 14700 Prag, Czech Republic
+420 222 96 90 22
Petr.Schejbal@ringspann.cz • www.ringspann.com

Ukraine

"START-UP" LLC.

Saltivske Hwy, 43, letter G-3, office 101,
Kharkiv 61038, Ukraine • +38 057 717 03 04
start-up@start-up.kh.ua • www.start-up.kh.ua

Asia

Australia, New Zealand

RINGSPANN Australia Pty Ltd

10 Network Drive, Carrum Downs Vic 3201,
Australia • +61 3 9069 0566
info@ringspann.com.au • www.ringspann.com.au

China, Taiwan

RINGSPANN Power Transmission (Tianjin) Co., Ltd.

No. 21 Gaoyan Rd., Binhai Science and Technology
Park, Binhai Hi-Tech Industrial, Development Area,
Tianjin, 300458, P.R. China • +86 22 5980 31 60
info.cn@ringspann.cn • www.ringspann.cn

India, Bangladesh, Nepal

RINGSPANN Power Transmission India Pvt. Ltd.

GAT No: 679/2/1, Village Kuruli, Taluka Khed, Chakan-
Alandi Road, Pune - 410501, Maharashtra, India
+91 21 35 67 75 00 • info@ringspann-india.com
www.ringspann-india.com

Singapore, ASEAN

RINGSPANN Singapore Pte. Ltd.

143 Cecil Street, #17-03 GB Building,
Singapore 069542 • +6012 589 8975
info@ringspann.sg • www.ringspann.sg

South Korea

RINGSPANN Korea Ltd.

33 Gojae-17 Ghil Dongnam-gu, 31187 Cheonan-si
Chungnam, South Korea • +82 10 54961 368
info@ringspann.kr • www.ringspann.kr

America

Brazil

Antares Acoplamentos Ltda.

Rua Evaristo de Antoni, 1222, Caxias do Sul, RS,
CEP 95041-000, Brazil • +55 54 32 18 68 00
vendas@antaresacoplamentos.com.br
www.antaresacoplamentos.com.br

Chile, Peru, Colombia, Ecuador

RINGSPANN Sudamérica SpA

Miraflores 222, Piso 28-N, Santiago,
Región Metropolitana, Chile • +56 9 9147 2833
info@ringspannsudamerica.com
www.ringspannsudamerica.com

USA, Canada, Mexico

RINGSPANN Corporation

10550 Anderson Place, Franklin Park, IL 60131, USA
+1 847 678 35 81
info@ringspanncorp.com
www.ringspanncorp.com

Africa and Middle East

Egypt

Shofree Trading Co.

218 Emtedad Ramsis 2, 2775 Nasr City, Cairo, Egypt
+20 2 20 81 20 57
info@shofree.com • www.ringspann.com

Maghreb, West Africa

SIAM - RINGSPANN S.A.

23 rue Saint-Simon, 69009 Lyon, France
+33 4 78 83 59 01
info@siam-ringspann.fr • www.ringspann.fr

Israel

G.G. Yarom Rolling and Conveying Ltd.

6, Hamaktesh Str., 58810 Holon, Israel
+972 3 557 01 15
noam_a@gg.co.il • www.ringspann.com

South Africa, Sub-Saharan

RINGSPANN South Africa (Pty) Ltd.

96 Plane Road Spartan, Kempton Park,
P.O. Box 8111 Edenglen 1613, South Africa
+27 11 394 1830
info@ringspann.co.za • www.ringspann.co.za